

**CUB CRAFTERS
CC18-180**

CUB CRAFTERS, INC.

**CC18-180 PILOT'S OPERATING HANDBOOK
AND FAA APPROVED AIRPLANE FLIGHT
MANUAL**

Serial Number: _____

Registration number: _____

This handbook includes the material required by the Federal Aviation Regulations to be furnished to the pilot. It also includes additional information provided by the manufacturer and constitutes the FAA Approved Flight Manual. This airplane is approved in the NORMAL CATEGORY, based on 14 CFR Part 23. This document must be carried in the airplane at all times.

Approved by the Federal Aviation Administration

By  _____

Thomas E. Archer II
Manager, Flight Test Branch
Seattle Aircraft Certification Office

Date: 7/1/09

CUB CRAFTERS, INC.
1918 South 16th Avenue
Yakima WA. 98903 USA
www.cubcrafters.com

**CUB CRAFTERS
CC18-180**

INTENTIONALLY LEFT BLANK

**CUB CRAFTERS
CC18-180**

WARNING

**THIS OPERATING MANUAL IS ONLY VALID FOR USE
WITH THE AIRCRAFT IDENTIFIED ON THE FACE
PAGE. ANY REVISIONS TO THIS MANUAL MUST BE
INSERTED AS APPROPRIATE.**

**CUB CRAFTERS
CC18-180**

INTENTIONALLY LEFT BLANK

CUB CRAFTERS CC18-180

APPLICABILITY

This manual is specifically applicable to CC18-180 serial number _____.

This manual must be kept up to date. Otherwise, it will cease to be valid. It is important that the owner register with Cub Crafters, Inc. in order to receive revisions in a timely fashion.

The aircraft may be operated legally only when the manual is maintained in a current status by the insertion of any revisions issued by Cub Crafters, Inc.

REVISIONS

Whenever revisions are received, they must be inserted in the appropriate place in the manual.

A black vertical line along the outside margin of the page will identify revised text and illustrations. Changes in spelling, punctuation and formatting will not be marked.

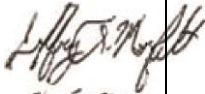
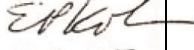
**CUB CRAFTERS
CC18-180**

INTENTIONALLY LEFT BLANK




CUB CRAFTERS CC18-180

LOG OF REVISIONS


Current revisions to the CC18-180 Pilot's Operating Manual, Report TC10000AFM and FAA Approved Flight Manual.

Revision	Revised Pages/ Sections	Description of Revision	FAA Approval Signature and Date
NC	ALL	Manual was document AFM-CC18-180. Has been renumbered TC10000AFM. Included EI engine instrumentation (Sec 2 and 7). Storage/ Accessory compartment Replaced figures section 7. Complete revision of Section 9. Minor changes from AFM-CC18-180.	
A	Section 0 Section 2	List of Effective Pages added. Page numbering adjusted. Placard wording for Fire Extinguisher and Static Source Changed.	 4-5-2005
B	Section 0 Section 2 Section 9	Revision to Handbook; changed footer. Changed placard design and orientation. Added avionic options.	 11-2-05




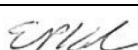
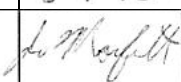
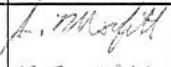
**CUB CRAFTERS
CC18-180**

Revision	Revised Pages/ Sections	Description of Revision	FAA Approval Signature and Date
C	Section 0 Section 6 Section 9	Revision to Handbook; Changed footer. Added floatplane data. Added section 9.11 Wipaire W2100 Amphibian Floats	 12-15-05
D	Section 0 Section 2 Section 4 Section 7 Section 9	Revision to Handbook; Changed footer. Changed placard design and location. Added Primer info. Updated instrument panel. Separated Supplement Subsections. Added Placard	 3-1-05
E	Section 0 Section 2 Section 5 Section 6 Section 7 Section 9	Revision to Handbook. Added Engine Model Number O-360-C1G. Added Optional Tires. Revised 6.3.1 to include unusable fuel. Revised 6.7 to include additional tire and tail wheel options. Revised 7.3 for Tail Wheel Options. Added Engine Model O- 360-C1G to 7.5.1. Added Artex Model ME406 to 7.10. Updated Figures for Artex. Added "NO PUSH" placard for Ventral Fin.	 5-7-08

CUB CRAFTERS CC18-180

Revision	Revised Pages/ Sections	Description of Revision	FAA Approval Signature and Date
F	Section 0 Section 2 Section 3 Section 4 Section 5 Section 6 Section 7 Section 9.11	Revision to Handbook. Added knots to all mph IAS Added °C to all temperatures. Added liters to all quart and gallon callouts Added CHT limitations. Added placards for metric unit callouts. Added Knots to all IAS. Revised statements into notes. Added knots to all mph IAS Added liters to all quart and gallon callouts. Added Note regarding Sensenich W80CM8 Propeller. Added knots and °C to 5.2.4. and 5.25. Added 5.3 for conversion charts. Added liters to quart callout. Added liters to quart callout. Added Fuel Selector Placard in metric units to Figure 7-6. Added knots to mph callout. Added °C to °F callout. Added knots to all mph IAS Added placards for metric unit callouts. Added knots and °C to 9.11.5.3.	 6-9-08

CUB CRAFTERS CC18-180

Revision	Revised Pages/ Sections	Description of Revision	FAA Approval Signature and Date
G	Section 0 Section 2 Section 3 Section 4 Section 9-11	Revision to Handbook. Corrected KIAS to 88. Revised Yellow Arc callout to 115-132. Corrected Liter amount. Revised Canadian Placard to 88 KIAS. Corrected KIAS to 88. Revised 3.3.4 to match 3.3.2. Corrected KIAS to 88. Added Master Switch Off to 4.3.1.1. Moved Vortex Generator check after Fuel Tank Check in 4.3.1.2 and 4.3.1.4. Added Alternator Belt and Air Filter Check to 4.3.1.3. Corrected KIAS to 88.	 8-13-10
H	Section 0 Section 2 Section 7	Revision to Handbook. Added placard to 2.19. Revised 7.5.11. Revised 7.5.13. Revised 7.7.	 4-27-11
J	Section 0	Revision to Handbook. Revised metric Fuel Capacity placard in 2.19.	 8-31-11
K	Section 0 Section 9.12	Revision to Handbook. Added Section 9.12 for Superior Engine	 8-1-12
L	Section 9.0 Section 9.11 Section 9.13	Updated Table of Contents. Revised 9.11.4.4.16. Added 9.13 for seaplane floats.	 12-3-2012
M	Section 0 Section 2	Revision to Handbook. Added Night VFR to 2.11. Added visor placard to 2.19.	 12-3-2012

CUB CRAFTERS CC18-180

M	Section 2	Updated placards in 2.19. Added "Maximum" to 2.4.	
	Section 3	Revised Magneto to Ignition for 3.3.2 to 3.3.5, 3.4.4	
	Section 4	Revised procedure in 3.3.10, 3.3.11, 3.4.10, and 3.4.11 Added cables and flap rods to 4.3.1.2 and 4.3.1.4.	
	Section 7	Added visors to 4.4.1.1. Updated images. Added dimmer controls to 7.5.11. Added visor to 7.7. Added visor to 7.9.	
N	Section 9	Updated 9-0 Table of contents Added section 9.14	<i>EPKL</i> 2-6-13
Q	Section 0 Section 9	Revision to Handbook. Added serial number effectivity and night lighting. Figure 9-11-22 updated, added night operation.	<i>EPKL</i> 5-27-14
R	Section 0 Section 2	Revision to Handbook. Added yellow arc oil temperature markings and added Winterization Kit Placard to 2.19.	<i>EPKL</i> 9-10-14
	Section 5	Changed wording from "takeoff" to "landing" and added figure references to 5.2.	
	Section 7	Added Kannad ELT to 7.10. Added Winterization Kit detail to 7.11. Added detail on oil pressure and temperature gauge to 7.7.2.	
	Section 9	Added yellow arc oil temperature markings to 9.12.	

**CUB CRAFTERS
CC18-180**

S	<p>Section 0 Section 9.11</p> <p>Section 9.12</p> <p>Section 9.13</p>	<p>Revision to Handbook Corrected Float hatches arm from 57.5 to 55. Wording throughout changed from "amphibian" to "amphibious"</p> <p>Added Sensenich callout. Added Sensenich to Table 2-2 title. Added Table 2-3 for McCauley Propeller data, added McCauley propeller to approved props note.</p> <p>Corrected even page header wording from "Amphibious" to "Seaplane".</p>	<p><i>EP/KL</i> 10-8-15</p>
T	<p>ALL</p> <p>Section 0</p> <p>Section 3</p> <p>Section 9 Section 9.15</p>	<p>Updated formatting, corrected typographical errors.</p> <p>Revision to Handbook, Effective Pages.</p> <p>Added door and touchdown bullet points. Changed bullet points for power on landing per title. Revised reference from 7.5.6 to 7.5.7.</p> <p>Updated Section 9 TOC. Added rear stick removal and stub cover installation instructions.</p>	<p><i>A. Moffitt</i> 3/29/16</p>
U	<p>Section 9 Section 9.16</p>	<p>Updated Section 9 TOC. Added Supplement 9.16.</p>	<p><i>Shan Rupp</i> 5/8/18</p>

CUB CRAFTERS CC18-180

List of Effective pages

Rev	Page No.	Change	Date	Prepared	Checked
NC	All	Initial Issue	5/13/05	ECL	ECL
A	0-3 0-5 2-12 2-13	List of Effective Pages added. Page numbering adjusted. Placard wording for Fire Extinguisher and Static Source changed.	7/29/05	MO	ECL
B	0-2 thru 0-3 2-i thru 2-16 2-10 thru 2-16 2-11 2-14 9-i thru 9-117 9-i 9-5 9-8 thru 9-13 9-10 9-24,25 9-27 thru 9-117	Log of Revisions, List of Effective pages; update footer Updated footer Changed placard design/ appearance Add Exterior Emergency Exit Placard Change location of Forward and Extended Cargo Placards Update footer Add to Table of Contents sections 9.4 thru 9.10 Delete "and passengers" Added TERRAIN data for COM/NAV Added missing abbreviations Removed reference to squat switch in 9.3.7.6 and 9.3.7.7 Added avionic options: sections 9.4 thru 9.10	9/21/05	RBB	ECL

CUB CRAFTERS CC18-180

Rev	Page No.	Change	Date	Prepared	Checked
C	0-2 0-4 6-i 6-5,18 Section 9-11-1 thru 9-11-66	Log of Revisions, List of Effective pages Updated table Added float data Added supplements section 9-11	11/28/05	RBB	ECL
D	0-3, 0-5 thru 0-6 2-10 2-11 2-14 4-9 4-11 7-18 9-0 thru 9-10 9-11-6	Log of Revision, List of Effective pages. Removed VFE speeds from placard on instrument panel (already on flap handle). Changed design of Fuel Selector Placard. Moved Forward and Extended Cargo Placards to cargo door Added Primer Warning. Added Primer to checklist. Updated instrument panel to reflect current production standard. Updated Header to specify subsection, changed page numbering to include subsection. Added Placard.	12/06/05	RBB	ECL

CUB CRAFTERS CC18-180

Rev	Page No.	Change	Date	Prepared	Checked
E	0-3 0-7 2-3 5-2 6-5 7-5 7-10 7-23 thru 25 9-11 All Pages 9-11-8	Log of Revisions. List of Effective pages. Added O-360- C1G Engine Option. Added Tachometer Red Arc Limitation. Added NOTE for Sensenich Propeller 76EM8. Added Table 5-1 for Propeller Options. Added NOTE for Sensenich Propeller 76EM8. Added note for unusable fuel. Added O-360- C1G Engine option. Added Fuel ventilation information. Added Artex ME406 ELT information and figures. Revised "W2100" to 2100A. Added "NO PUSH" placard for Ventral Fin.	04/18/08	SJT	SJH
F	0-4 0-7 thru 0-8 2-1 thru 3 2-3 2-7 thru 2- 14 3-1 thru All	Log of Revisions. List of Effective pages. Added knots option to all IAS. Added °C to °F listed. Added CHT Max. Added optional metric placard. Added knots option to all IAS.	06/04/08	SJT	SJH

CUB CRAFTERS CC18-180

Rev	Page No.	Change	Date	Prepared	Checked
F cont	3-3	Revised statement to WARNING.			
	3-3, 3-6, 3-9, 3-10, 3-11	Revised statement to NOTE.			
	4-1 thru All	Added knots option to all IAS Added liter option to all quart callouts.			
	5-1	Added statement for conversion chart addition.			
	5-3	Added NOTE for Sensenish W80CM8.			
	5-13 thru 5-16	Added knots to Airspeed column.			
	5-13 thru 5-16	Added °C to OAT column.			
	5-23 thru 5-26	Added Conversion Charts.			
	6-5	Added liter option to quart callout.			
	7-9	Added liter option to quart callout.			
	7-11	Added Fuel Selector Photo in liters.			
	7-13	Added knot option to mph callout.			
	9-11 All Pages	Added knots option to all IAS Added liter option to all quart callouts. Added Placard in KIAS.			
	9-11-6	Added knots to Airspeed column.			
	9-11-41 and 42	Added °C to OAT column.			

CUB CRAFTERS CC18-180

Rev	Page No.	Change	Date	Prepared	Checked
G	0-5	Log of Revisions	07/06/10	SJT	SJH
	0-11	List of Effective pages.			
	2-1	Corrected KIAS in Section 2.2.			
	2-2	Revised Table 2-1.			
	2-6	Corrected Liter callout.			
	2-7	Corrected IAS Placard to 88 KIAS.			
	3-2	Corrected KIAS in Section 3.2.			
	3-7	Added throttle, brakes, wing flaps and mixture to 3.3.4.			
	3-11	Corrected KIAS in Section 3.3.9			
	3-22	Corrected KIAS in Section 3.4.9.			
	4-1	Corrected KIAS in Section 4.2.			
	4-3	Added Master Off to 4.3.1.1.			
	4-4	Moved Vortex Generator check to after Fuel Tank.			
	4-5	Added Alternator Belt and Air Filter to check list.			
	4-6	Moved Vortex Generator check to after Fuel Tank.			
9-11-15	Corrected KIAS in Section 9.11.4.2.				
H	0-6	Revision to Handbook.	03/31/11	SJT	ECL
	0-11	Effective Pages.			
	2-7	Added Compass Deviation Placard.			
	7-13, 7-14, 7-18	Added information for magnetic compass deviation when pitot heat and/or landing/taxi lights are on.			

CUB CRAFTERS CC18-180

Rev	Page No.	Change	Date	Prepared	Checked
J	0-6 0-12 2-9	Revision to Handbook. Effective Pages. Revised Fuel Placard in Metric.	08/26/11	SJT	ECL
K	0-6 0-12 9-12-1	Revision to Handbook. Effective Pages. Added Section 9.12 supplement for Superior Air Parts 0-360-A3A2 Engine	07/18/12	ECL	ECL
L	9-0-i 9-11-24 9-11-26 9-13-1	Updated TOC Corrected Best Angle. Corrected to Control Stick. Added supplement for Wipaire 2100 Series Seaplane floats.	10/09/12	MRG	ECL
M	0-6 0-12 2-5 2-8 3-4 thru 3-8 3-12 3-13 3-18 3-23 thru 3-24 4-4 thru 4-6 4-16 7-11 thru 7-25 7-22	Revision to Handbook. Effective Pages. Added Night VFR Added placard Revised Magneto to Ignition Revised procedure Revised procedure Revised Magneto to Ignition Revised procedure Added cables and flap rods to checklist Added visor Updated images Added visor	11/20/12	AMS / MRG	ECL

CUB CRAFTERS CC18-180

Rev	Page No.	Change	Date	Prepared	Checked
N	0-7 0-14 9-0 9-14-1	Revision to Handbook. Effective Pages. Updated TOC. Added Section 9.14 supplement for GTN 635.	02/05/13	MRG	ECL
Q	0-7 0-14 9-11-7 9-11-12 9-11-61 thru 9-11-62 9-11-65	Revision to Handbook. Effective Pages. Revised figure titles to include serial number effectivity Revised to include night operation Revised figure titles to include serial number effectivity Figure 9-11-22 updated, added night operation	5/21/14	VCS	ECL
R	0-7 0-14 2-3 2-8 5-18 and 5-20 7-22 7-27 7-28 9-12-3	Revision to Handbook. Effective Pages. Added yellow arc oil temperature markings. Added Winterization Kit Placard. Corrected wording from "takeoff" to "landing" and added figure references. Added detail on oil pressure and temperature gauge. Added Kannad ELT detail and figure. Added Winterization Kit detail. Added yellow arc oil temperature markings.	06/20/14	VCS	ECL

CUB CRAFTERS CC18-180

Rev	Page No.	Change	Date	Prepared	Checked
S	0-8 0-16 9-11: ALL 9-11-38 9-13-58 9-12-2 9-12-3 9-12-4 9-13: ALL	Revision to Handbook. Effective Pages Wording throughout changed from "amphibian" to "amphibious" Corrected wording from 57.5 to 55. Corrected wording from 57.5 to 55. Added Sensenich callout. Added Sensenich to Table 2-2 title. Added Table 2-3 for McCauley Propeller data, added McCauley propeller to approved props note. Corrected even page header wording from "Amphibious" to "Seaplane".	09/15/15	VCS	ECL
T	ALL 0-8 0-16 3-8 3-17 9-0-i 9.15: ALL	Updated formatting, corrected typographical errors. Revision to Handbook. Effective Pages. Added door and touchdown bullet points. Changed bullet points for power on landing per title. Revised reference from 7.5.6 to 7.5.7. Updated TOC. Added rear stick removal and stub cover installation instructions.	01/13/16	VCS	ECL

**CUB CRAFTERS
CC18-180**

Rev	Page No.	Change	Date	Prepared	Checked
U	9-0-i 9.16: ALL	Updated TOC. Added Supplement 9.16.	05/04/18	MH	ECL

**CUB CRAFTERS
CC18-180**

INTENTIONALLY LEFT BLANK

**CUB CRAFTERS
CC18-180**

TABLE OF CONTENTS

SECTION 1	GENERAL INFORMATION
SECTION 2	LIMITATIONS
SECTION 3	EMERGENCY PROCEDURES
SECTION 4	NORMAL PROCEDURES
SECTION 5	PERFORMANCE
SECTION 6	WEIGHT AND BALANCE
SECTION 7	DESCRIPTION AND OPERATION OF THE AIRCRAFT AND ITS SYSTEMS
SECTION 8	RESERVED
SECTION 9	SUPPLEMENTS

**CUB CRAFTERS
CC18-180**

INTENTIONALLY LEFT BLANK

TABLE OF CONTENTS

SECTION 1

GENERAL INFORMATION

Paragraph		Page
1.1	INTRODUCTION.....	1-1
1.2	WARNINGS, CAUTIONS AND NOTES..	1-2

INTENTIONALLY LEFT BLANK

1 GENERAL INFORMATION

1.1 INTRODUCTION

This Pilot's Operating Manual contains information required by the FAA at the time the CC18-180 was certified. It also has additional data which Cub Crafters, based on its experience, has found useful.

This manual is the Approved Pilot's Operating Handbook and it is part of the equipment that must be onboard the aircraft whenever it is operated.

This manual is not intended to be a flight instruction manual. It is not a substitute for adequate, competent flight training, knowledge of current Airworthiness Directives affecting the airplane, or applicable aviation regulations.

The pilot-in-command is responsible for determining whether the airplane is safe for flight. He/she is also responsible for ensuring that all operations are conducted within the limitations defined by this manual, instrument markings, and appropriate placards.

While it is intended that this manual be used in flight, it must be studied regularly. The pilot must be familiar with all limitations, performance, procedures, and operational handling characteristics of the airplane prior to flight.

The information in this manual is divided into numbered sections, each of which is provided with a tab divider. The order of the sections has been designed so that the **LIMITATIONS** and **EMERGENCY SECTIONS** may be looked up quickly. The **EMERGENCY SECTIONS** has a red divider tab.

1.2 WARNINGS, CAUTIONS AND NOTES

WARNINGS, CAUTIONS, and NOTES are used to emphasize critical and important information and are used as defined below:

WARNING

AN OPERATING PROCEDURE, PRACTICE, OR A CONDITION WHICH, IF NOT CORRECTLY FOLLOWED OR REMEDIED, COULD RESULT IN SERIOUS PERSONAL INJURY OR LOSS OF LIFE.

CAUTION

An operating procedure, practice, or a condition which, if not strictly observed or corrected, could result in destruction of or damage to equipment.

NOTE

An operating procedure, practice, or condition which is important to emphasize.

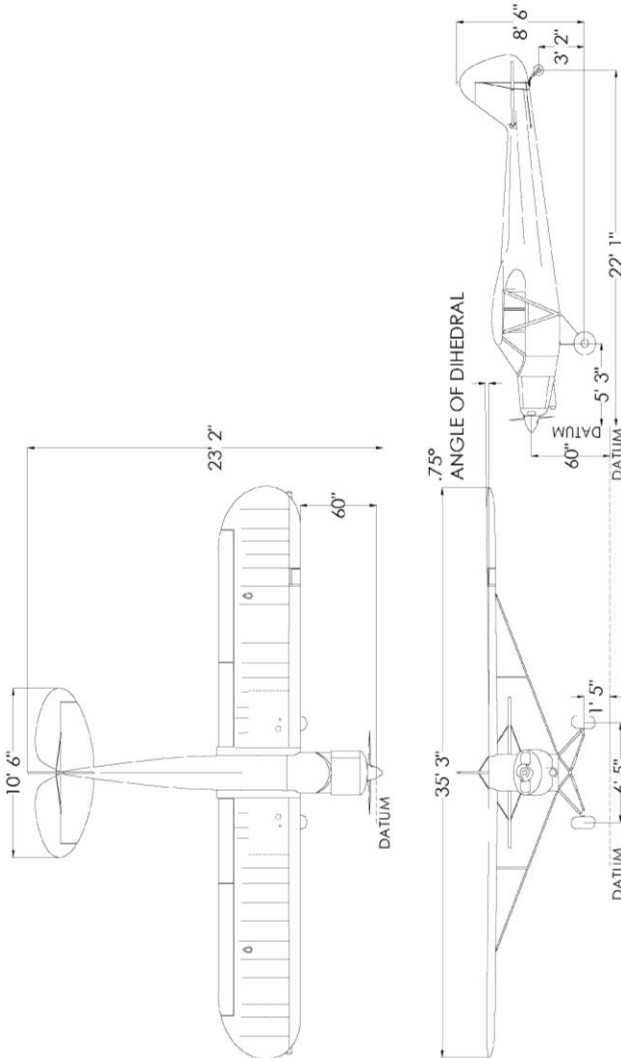


Figure 1-1 Three views of the CC18-180

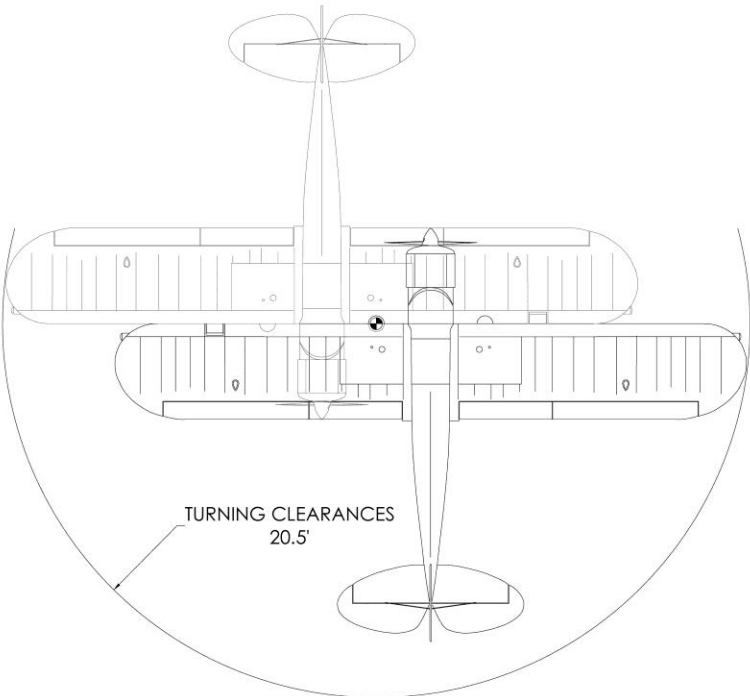


Figure 1-2 Turning radius

TABLE OF CONTENTS

SECTION 2

LIMITATIONS

Paragraph	Page
2 LIMITATIONS.....	2-1
2.1 GENERAL.....	2-1
2.2 AIRSPEED LIMITATIONS.....	2-1
2.3 AIRSPEED INDICATOR MARKINGS.....	2-2
2.4 POWERPLANT LIMITATIONS	2-3
2.5 POWERPLANT INSTRUMENT MARKINGS.....	2-3
2.6 WEIGHT LIMITS.....	2-4
2.7 CENTER OF GRAVITY.....	2-4
2.8 MANEUVERS.....	2-4
2.9 MANEUVER LOAD FACTORS.....	2-4
2.10 MINIMUM FLIGHT CREW	2-5
2.11 KINDS OF OPERATION	2-5
2.12 MAXIMUM OPERATING ALTITUDE	2-5
2.13 MAXIMUM PASSENGER SEATING CONFIGURATION.....	2-5
2.14 ALLOWABLE FUEL LOADING	2-6
2.15 BAGGAGE AND CARGO LOADING	2-6
2.16 SMOKING.....	2-6
2.17 TYPES OF SURFACES.....	2-6
2.18 VORTEX GENERATORS	2-6
2.19 PLACARDS	2-7

INTENTIONALLY LEFT BLANK

2 LIMITATIONS

2.1 GENERAL

This section provides the FAA Approved operating limitations, instrument markings, color-coding and basic placards for operation of the Cub Crafters CC18-180 aircraft.

Limitations associated with those optional systems and equipment which requires handbook supplements can be found in Section 9 “Supplements”.

2.2 AIRSPEED LIMITATIONS

SPEED	IAS	
	MPH	KNOTS
Never Exceed Speed V_{NE}	152	132
DO NOT EXCEED THIS SPEED IN ANY OPERATION.		
Maximum Operating Maneuvering Speed V_o		
At 2300 lbs. gross weight	102	88
At 1800 lbs. gross weight	90	78
At 1300 lbs. gross weight	76	66

Do not make full or abrupt control movements above this speed.

CAUTION

Maximum operating speed decreases at lighter weight as the effects of aerodynamic forces become more pronounced. Linear interpolation may be used for intermediate gross weights.

SPEED	IAS	
	MPH	KNOTS
Maximum Flaps Extended Speed V_{FE}		
First Notch (22°)	98	85
Full Flaps (50°)	89	77

Do not exceed the flap speed corresponding to a given setting.

2.3 AIRSPEED INDICATOR MARKINGS

Airspeed indicator markings and their significance are shown in Table 2-1.

MARKING	SPEED RANGE OR VALUE (IAS)		SIGNIFICANCE
	MPH	KNOTS	
Red Radial Line	152	132	Never exceed speed V_{NE}
Yellow Arc	133-151	115-131	Operations must be conducted with caution and in smooth air
Green Arc	54-132	47-114	Normal operating range
White Arc	48-89	42-77	Operating range with full flaps extended (50°)

Table 2-1 - Airspeed Indicator Markings

2.4 POWERPLANT LIMITATIONS

Engine manufacturer..... Textron Lycoming
 Engine model number O-360-C4P
 O-360-C1G
 Engine operating limits
 Takeoff power 180 bhp
 Maximum Engine Speed 2700 RPM
 Oil pressure, Minimum 25 psi
 Oil pressure, Maximum 115 psi
 Oil temperature, Maximum 245 °F or 118 °C
 Fuel limitations (grade) 100 or 100LL
 Maximum Cylinder Head Temp 500 °F or 260 °C
 If equipped with CHT gauge.

2.5 POWERPLANT INSTRUMENT MARKINGS

TACHOMETER	Red Radial Line	2700 RPM	
	Red Arc*	2150-2350 RPM*	
	Green Arc (normal operating range)	500-2699 RPM	
OIL PRESSURE	Red Radial Line (minimum)	24 PSI	
	Yellow Arc (caution, low)	25-59 PSI	
	Green Arc (normal)	60-94 PSI	
	Yellow Arc (caution, high)	95-114 PSI	
	Red Radial Line (maximum)	115 PSI	
OIL TEMPERATURE	Yellow Arc* *	0-99°F	-18-37°C
	Green Arc (normal)	100-244°F	38-117°C
	Red Radial Line (maximum)	245°F	118°C

Table 2-2 Powerplant Instrument Markings

NOTE

* Only applicable to Sensenich Propeller 76EM8 when used with Lycoming O-360-C1G engine per AD 69-09-03.

NOTE

* *A yellow low oil temperature indication below 100°F is a cautionary indication provided to emphasize when the engine is operating outside the normal range. Takeoff must not be initiated when the oil temperature is below 100°F unless the engine accelerates smoothly when the throttle is opened.

2.6 WEIGHT LIMITS

Maximum weight..... 2300 lbs.
Minimum operating weight 1300 lbs.

2.7 CENTER OF GRAVITY

Forward (at 2300 lbs.) 79.1 in. aft of Datum
(at 1600 lbs. or less)..... 70.5 in. aft of Datum
Straight line variation between points given
Rearward (at all weights) 81.0 in. aft of Datum

The datum is 60 in. forward of wing leading edge.

2.8 MANEUVERS

This is a normal category airplane. All acrobatic maneuvers, including spins, are prohibited.

2.9 MANEUVER LOAD FACTORS

Maximum positive load factor, flaps up..... 3.8 g
Maximum positive load factor, flaps down 2.0 g
Maximum negative load factor -1.5 g
No inverted maneuvers approved.

2.10 MINIMUM FLIGHT CREW

The minimum required flight crew is one pilot in the front seat. This does not preclude a qualified flight instructor giving dual instruction from the back seat.

2.11 KINDS OF OPERATION

Aircraft Serial Number 0056 and on, and Aircraft 0002 through 0055 modified in accordance with Service Letter 002, Day, Night VFR. Night visors must be installed for night operations. Other aircraft Day VFR only.

Flight into known icing is prohibited.

2.12 MAXIMUM OPERATING ALTITUDE

The maximum operating altitude will vary depending on the type of propeller used. With the Sensenich Propeller Manufacturing Company, Inc., model 76EM8, 76 in. diameter, 56 in. pitch propeller, the maximum operating altitude is 14,600 feet at gross weight. To comply with the operating rules of 14 CFR Part 91, an approved oxygen system must be in use when flying above 14,000 feet.

2.13 MAXIMUM PASSENGER SEATING CONFIGURATION

The CC18-180 is approved to carry one passenger, seated behind the pilot.

2.14 ALLOWABLE FUEL LOADING

50 US gallons or 189.3 liters.

2.15 BAGGAGE AND CARGO LOADING

Under passenger seat storage.....5 lbs.
Forward cargo (behind passenger)180 lbs.
Extended cargo compartment.....20 lbs.
 (behind forward cargo compartment)
Storage/accessory compartment5 lbs.

2.16 SMOKING

No smoking is allowed in the CC18-180.

2.17 TYPES OF SURFACES

The CC18-180 may be operated from paved and unpaved runways.

2.18 VORTEX GENERATORS

The CC18-180 is allowed to fly with the following number of vortex generators missing:

- Not more than three vortex generators missing on an aircraft.
- Not more than two vortex generators missing on a wing.
- The missing vortex generators must not be next to each other.

If there are vortex generators missing, the maximum takeoff weight of the aircraft is limited to 2100 lbs.

2.19 PLACARDS

In view of the pilot:

THIS AIRCRAFT MUST BE OPERATED AS A NORMAL CATEGORY AIRCRAFT IN COMPLIANCE WITH THE OPERATING LIMITATIONS STATED IN THE FORM OF PLACARDS, MARKINGS AND MANUALS. NO ACROBATIC MANEUVERS (INCLUDING SPINS) ARE APPROVED. THIS AIRCRAFT IS APPROVED FOR VFR DAY AND NIGHT OPERATIONS ONLY. FLIGHT INTO KNOWN ICING IS PROHIBITED.

NO SMOKING

On the instrument panel:

V_0 102 MPH (IAS) @ 2300 lbs

or

V_0 88 KIAS @ 2300 lbs

**MAXIMUM FUEL
IMBALANCE**
5 GALLONS DIFFERENCE
BETWEEN TANKS

**MAXIMUM FUEL
IMBALANCE**
19 LITERS DIFFERENCE
BETWEEN TANKS

or

NXXXXX

FOR	N	30	60	E	120	150
STEER						
FOR	S	210	240	W	300	330
STEER						
DATE: XX/XX/XXXX						

MAGNETIC COMPASS MAY
HAVE DEVIATIONS GREATER
THAN 10° WHEN LANDING
LIGHTS OR PITOT HEAT
ARE ON.

**NIGHT VISORS MUST
BE INSTALLED FOR
NIGHT OPERATIONS.
SEE AFM FOR
INSTALLATION.**

**WINTERIZATION KIT
MUST BE REMOVED FOR
OPERATIONS ABOVE 40°F
OAT. SEE SL0003 FOR
INSTALLATION.**

On left panel, under sliding windows:

**EMERGENCY EXIT
PUSH WINDOWS OUT**

On outside of sliding glass window:

**EMERGENCY EXIT
PULL WINDOWS OUT**

Flaps placard, on or next to flap handle:

FLAPS
1st NOTCH 22°
MAX 98
MPH IAS

2nd NOTCH
FULL, 50°
MAX 89
MPH IAS

OR

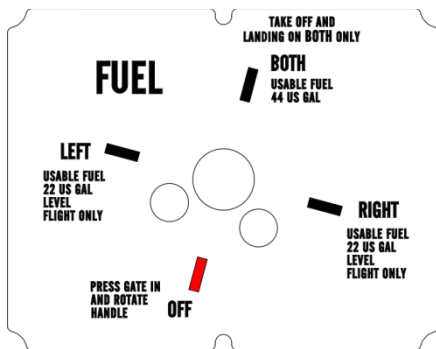
FLAPS
1st NOTCH 22°
MAX 85
KIAS

2nd NOTCH
FULL, 50°
MAX 77
KIAS

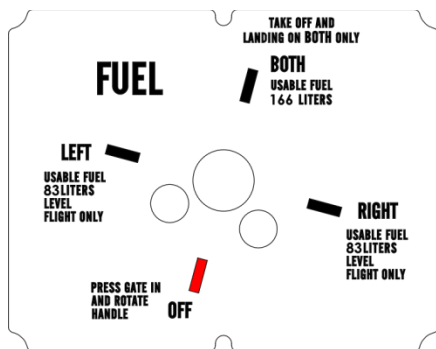
Next to static ports on fuselage side:

**STATIC SOURCE
KEEP CLEAR**

Behind the fuel selector:



OR



Next to sight gauges:



or



On front floorboard:



On left panel, under sliding windows:



On door (inside):



On door (outside):



On top inboard of all lift struts:



Inside under-seat storage compartment:

MAXIMUM CAPACITY
5 LBS

On cross bar behind passenger seat:

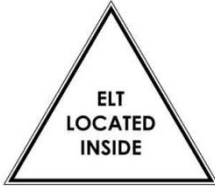
SEAT BAR MUST BE SECURED BEFORE FLIGHT

On baggage compartment door:

**FORWARD CARGO
COMPARTMENT**
→
**MAX CAPACITY
180 LBS**
→
**CARGO TIE DOWN
RATED 50 LBS EACH**

**EXTENDED CARGO
COMPARTMENT**
←
**MAX CAPACITY
20 LBS**
←
**DISTRIBUTE LOAD EVENLY
SEE AFM**

Upper storage/accessory compartment door:



On inside of storage/accessory compartment:

ONLY STORAGE OF SOFT ITEMS SUCH AS
COVERS, COATS, HATS ETC. PERMITTED
WEIGHT NOT TO EXCEED 5 LBS

Near each fuel drain:



Front surface of cowl inlet blocking plates and oil cooler plate (this plate must be removed when OAT exceeds 40°F):

MAX OPERATING TEMPERATURE: 40°F OAT

On inside of right cowl:

OIL		
CAPACITY 8 QUARTS		
APPROVED TYPES		
AVERAGE AMBIENT TEMPERATURE	J-1966 MINERAL SAE GRADES	J-1899 ASHLESS DISPERSANT SAE GRADES
ALL TEMPERATURES	----	15W-50 OR 20W-50
ABOVE 80°F	60	60
ABOVE 60°F	50	40 OR 50
30°F TO 90°F	40	40
0°F TO 70°F	30	30, 40, OR 20W-40
BELOW 10°F	20	30 OR 20W-30

OR

OIL		
CAPACITY 7.6 LITERS		
APPROVED TYPES		
AVERAGE AMBIENT TEMPERATURE	J-1966 MINERAL SAE GRADES	J-1899 ASHLESS DISPERSANT SAE GRADES
ALL TEMPERATURES	----	15W-50 OR 20W-50
ABOVE 26°C	60	60
ABOVE 15°C	50	40 OR 50
-1°C TO 32°C	40	40
-17°C TO 21°C	30	30, 40, OR 20W-40
BELOW -12°C	20	30 OR 20W-30

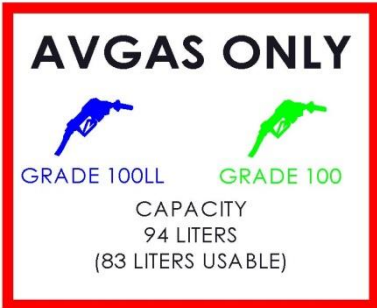
Next to stall warning vane:

<p>STALL WARNING VANE KEEP CLEAR VANE MUST NOT BE PAINTED</p>
--

On wing next to tank filler:



or



Next to tie downs:

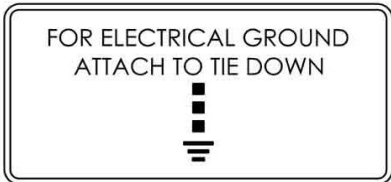


TABLE OF CONTENTS

SECTION 3

EMERGENCY PROCEDURES

Paragraph	Page
3	EMERGENCY PROCEDURES..... 3-1
3.1	GENERAL 3-1
3.2	AIRSPEDS FOR EMERGENCY OPERATIONS..... 3-2
3.3	EMERGENCY CHECKLIST 3-3
3.3.1	ENGINE FIRE DURING START 3-3
3.3.2	ENGINE FAILURE DURING TAKEOFF..... 3-4
3.3.3	LOSS OF ENGINE POWER IN FLIGHT 3-6
3.3.4	EMERGENCY LANDING WITHOUT ENGINE POWER 3-7
3.3.5	PRECAUTIONARY LANDING WITH ENGINE POWER..... 3-8
3.3.6	FIRE IN FLIGHT 3-9
3.3.7	LOSS OF OIL PRESSURE..... 3-11
3.3.8	HIGH OIL TEMPERATURE 3-11
3.3.9	EMERGENCY DESCENT 3-11
3.3.10	ALTERNATOR FAILURE 3-12
3.3.11	OVERVOLTAGE 3-13
3.3.12	INADVERTENT SPIN 3-13
3.3.13	INADVERTENT ICING ENCOUNTER 3-14
3.4	AMPLIFIED EMERGENCY PROCEDURES..... 3-15
3.4.1	ENGINE FIRE DURING START 3-15
3.4.2	ENGINE FAILURE DURING TAKEOFF..... 3-16
3.4.3	TOTAL LOSS OF ENGINE POWER IN FLIGHT 3-17
3.4.4	EMERGENCY LANDING WITHOUT ENGINE POWER..... 3-18

3.4.5 PRECAUTIONARY LANDING WITH ENGINE
POWER..... 3-19

3.4.6 FIRE IN FLIGHT 3-20

3.4.7 LOSS OF OIL PRESSURE..... 3-21

3.4.8 HIGH OIL TEMPERATURE 3-21

3.4.9 EMERGENCY DESCENT 3-22

3.4.10 ALTERNATOR FAILURE 3-23

3.4.11 OVERVOLTAGE 3-24

3.4.12 INADVERTENT SPIN 3-24

3.4.13 INADVERTENT ICING ENCOUNTER 3-25

3 EMERGENCY PROCEDURES

3.1 GENERAL

This section provides the recommended procedures that should be followed when encountering an emergency or a critical situation. It is divided into two parts. The first contains emergency procedure checklists. The second part amplifies the items listed in the checklists and includes information that is not readily adaptable to a checklist format or which the pilot could not be expected to refer to in an emergency situation. This information should be reviewed regularly.

Pilots must familiarize themselves with the procedures in this section and must be prepared to take appropriate action should an emergency arise.

It is stressed that the procedures outlined in this section are recommendations only. They are not a substitute for sound judgment and common sense and may have to be adjusted depending on the circumstances prevailing at the time of the emergency. It is important that the pilot be thoroughly familiar with the aircraft. He/She must review and practice as many of these procedures as are safe to perform as part of his/her training.

Whenever airspeeds are quoted, they assume the propeller/tire configuration that gives the most conservative performance.

Above all, in any emergency situation, **MAINTAIN CONTROL OF THE AIRCRAFT.**

3.2 AIRSPEEDS FOR EMERGENCY OPERATIONS

	IAS	
	MPH	KNOTS
STALL SPEED		
Flaps Up (V_{S1})	54	47
Flaps Down (50°) (V_{S0})	48	42
OPERATING MANEUVERING SPEED (V_O)		
At 2300 lbs	102	88
BEST GLIDE (V_G)		
Flaps Up (2300 lbs)	68	59

Configuration:

- McCauley Propeller Systems - M1A200/FA, 82 in. diameter, 40 in. pitch
- 26x10.5-6 Goodyear Tires & Wheels

3.3 EMERGENCY CHECKLIST

3.3.1 ENGINE FIRE DURING START

Starter..... Crank engine

Continue to get a start that would suck the flames and associated fire into the engine.

If engine starts:

- Power.....1700 RPM for a three minutes
- Engine.....Shut down by pulling mixture to idle cut-off

NOTE

Have a qualified technician thoroughly inspect the engine and the airframe.

If engine fails to start:

- Mixture Idle cut-off
- ThrottleOpen
- Fuel Selector.....Off

NOTE

Have a qualified technician thoroughly inspect the engine and the airframe.

IF FIRE PERSISTS:

Fire Extinguisher If safe to do so, remove and attempt to extinguish fire.

WARNING

**IF UNABLE TO EXTINGUISH FIRE, ABANDON
AIRCRAFT AND CALL FOR HELP.**

3.3.2 ENGINE FAILURE DURING TAKEOFF

PRIOR TO LIFT-OFF

- Maintain directional control.
- ThrottleIdle
- BrakesApply as necessary
- Wing Flaps Retract
- Mixture..... Idle cut-off
- Ignition Switch Off
- Master Switch..... Off

AFTER LIFT-OFF

If sufficient runway remains for a normal landing, land straight ahead.

If insufficient runway remains:

- Maintain a safe airspeed.
- Use shallow turn to avoid obstructions.
- Use of flaps depends on circumstances. Normally, flaps should be fully extended for touchdown.

If you have gained sufficient altitude to attempt a restart, proceed as follows:

- Maintain safe airspeed.
- Fuel Selector..... Both
- Mixture Check Rich
- Ignition Switch Ensure Both
- Starter Engage

If restart is unsuccessful, when landing area assured:

- Ignition SwitchOff
- Master SwitchOff
- Fuel Selector.....Off
- ELTActivated
- Seat Belts Tight and secure
- DoorOpen
- Touchdown At the lowest possible airspeed

3.3.3 LOSS OF ENGINE POWER IN FLIGHT

	IAS	
	MPH	KNOTS
If at low altitude:		
Airspeed (minimum)	68	59
If altitude permits:		
With Flaps Up, MAINTAIN	68	59
With Flaps Down,	53	46
<ul style="list-style-type: none">• Fuel SelectorBoth• Mixture..... Full rich• Carburetor Heat On (Hot)• Ignition SwitchEnsure Both• Engine InstrumentsCheck for indication of cause of engine power loss• Starter.....Engage		

NOTE

If power is not restored and is insufficient to sustain level flight, prepare for power off landing.

**3.3.4 EMERGENCY LANDING WITHOUT ENGINE
POWER**

Locate suitable field.

	IAS	
	MPH	KNOTS
Airspeed (flaps up)	68	59
Seat belts	Tight and secure	

When landing area assured:

- Flaps As required
- Door Open
- Touchdown At the lowest possible airspeed
- ELT Activate

When aircraft comes to a stop:

- Throttle Idle
- Brakes Set
- Wing Flaps Retract
- Mixture Idle Cut-Off
- Ignition Switch Off
- Master Switch Off
- Fuel Selector Off

If time permits, check GPS or charts for airports in the immediate vicinity. If possible, notify your difficulty and intentions by radio and/or squawk 7700.

If practical, establish spiral pattern above the selected landing field. Fly a normal downwind approach, 1000' AGL abeam the desired landing point, noting any obstacles. Plan your initial approach for the middle of the field.

3.3.5 PRECAUTIONARY LANDING WITH ENGINE POWER

Seat beltsTight and secure
MixtureSet

Fly Approach (IAS)	MPH	KNOTS
Flaps Up, MAINTAIN	68	59
Flaps Down	53	46

- Door..... Open
- Touchdown.....At the lowest possible airspeed, with full flaps.

After touchdown:

- Throttle Idle
- Mixture..... Idle-Cut Off
- Ignition Switch..... Off
- Master Switch..... Off
- Fuel Selector Off

If time permits, check GPS or charts for airports in the immediate vicinity.

If possible and if you are in contact with Air Traffic Control or another aircraft, notify your difficulty and intentions by radio on frequency 121.50 and/or squawk 7700, as appropriate.

Fly normal downwind approach 1000' AGL abeam the desired landing field, noting obstacles.

3.3.6 FIRE IN FLIGHT

- Source of fireLocate

ELECTRICAL FIRE

- Master SwitchOff
- WindowsOpen
- Cabin Door.....Open

If source of fire is located and it is safe and practical:

- Fire Extinguisher.....Activate
- Land as soon as possible

If fire has been extinguished and electrical power is essential for the continuation of the flight to the nearest suitable airport or landing area,

- All electrical switchesOff
- Avionics master switch and avionicsOff
- Circuit breakers Check for faulty circuit

NOTE

If any breakers are out, note the circuits but do not reset or use the equipment powered by these circuits.

- Master switch.....On
- Avionics master switch.....On
- Avionics and electrical switches.... On, one at a time, with a delay after each, to ensure that problem does not recur.

ENGINE FIRE:

- Fuel Selector Off
- Throttle Idle
- Mixture Idle cut-off
- Cabin Heater Off
- Airspeed Maintain the highest possible,
within limitations

NOTE
Proceed with EMERGENCY LANDING WITHOUT
ENGINE POWER.

3.3.7 LOSS OF OIL PRESSURE

- Land as soon as practical and investigate cause.
- Prepare for emergency landing without power.

3.3.8 HIGH OIL TEMPERATURE

- Airspeed.....Increase
- Power..... Reduce as much as practical

NOTE

Land as soon as practical and investigate cause.
Prepare for emergency landing without power.

3.3.9 EMERGENCY DESCENT

WARNING

**DO NOT EXCEED 152 MPH OR 132 KNOTS (IAS)
IN SMOOTH AIR WITH FLAPS UP.**

**DO NOT EXCEED 102 MPH OR 88 KNOTS (IAS)
IN ROUGH AIR WITH FLAPS UP.**

**DO NOT EXCEED 89 MPH OR 77 KNOTS (IAS)
WITH FLAPS DOWN.**

- Throttle..... Idle
- Airspeed.....Do not exceed limitations

3.3.10 ALTERNATOR FAILURE

Alternator output failure is indicated by the illumination of the battery discharge light and the ammeter will show a negative number.

To verify the alternator has failed:

- Electrical Load Reduce
- Ammeter Indication
 - Positive:..... Alternator functioning correctly
 - Negative: Re-set DC system

The alternator circuit breaker may also have tripped. Output failure may be the result of a mechanical failure of the alternator, failure of the alternator drive belt or a momentary over-voltage condition.

To re-set the DC system:

- Battery Master Switch Off

Allow at least 10 seconds delay

- Circuit Breakers..... Check, Pushed In
- Battery Master Switch..... On

If alternator power is NOT restored, determine what electrical equipment is essential to continue the flight and land as soon as practical. Battery power is the only source of electrical power. Anticipate complete electrical failure.

- Electrical Load Reduce

3.3.11 OVERVOLTAGE

If the bus voltage rises above 15.3 volts, a bright red “High Volts” light will illuminate.

- Battery Master SwitchOff

Wait 1 minute and switch master switch on and monitor voltage. If the “High Volts’ light comes on again, pull alternator and field circuit breakers and continue flight as failed alternator, determine what electrical equipment is essential to continue the flight and land as soon as practical. Battery power is the only source of electrical power. Anticipate complete electrical failure.

3.3.12 INADVERTENT SPIN

- Aileron Control Neutral
- Throttle Closed
- Rudder Full opposite to direction of spin
- Elevator Control Stick forward to break stall
- Elevator & Throttle As required
To resume level flight smoothly

If flaps were down, retract once a safe flying speed has been attained. Ensure that the flap speed is not exceeded (89 mph or 77 knots IAS).

CAUTION
This recovery procedure is applicable only when the aircraft is in a spin. Application of controls as described above during a stall or after the aircraft has stopped gyrating may cause the aircraft to enter into a spin.

3.3.13 INADVERTENT ICING ENCOUNTER

WARNING
THIS AIRCRAFT IS NOT APPROVED FOR FLIGHT INTO KNOWN ICING. FLIGHT INTO KNOWN ICING CONDITIONS IS PROHIBITED.

CAUTION
Ice accumulation on the wings and other airframe components will greatly increase the stall speed of the airplane and result in unpredictable flight characteristics.
Ice accumulation over engine induction air inlet can cause engine roughness and/or loss of power.
Ice formations on the propeller may cause severe propeller/engine vibrations.
Ice accumulation over the pitot and/or static ports of the air speed indicating system may cause erroneous air speed, altitude and VSI indications.
Ice build-up on the windshield will distort vision and probably obscure forward visibility.

At first indication of encountering icing conditions:

- Pitot Heat..... On
- Carburetor Heat On (Hot)

Fly towards warmer air, clear of visible moisture and/or descend to lower altitude if safe to do so.

3.4 AMPLIFIED EMERGENCY PROCEDURES

3.4.1 ENGINE FIRE DURING START

Engine fires during starting may be caused by excessive use of the engine fuel primer. The first attempt to extinguish the fire should be to draw the excess fuel into the engine.

If the engine has not already started, the mixture must be moved to cut-off and the throttle opened fully before cranking the engine.

If the engine starts, and fire goes out within a few seconds, run it at 1700 RPM for a few minutes.

If the fire continues for more than a few seconds, it should be extinguished by the best available external means.

WARNING

IF A FIRE IS ON THE GROUND, UNDER THE AIRPLANE, DUE TO OVER-PRIMING, AND THE ENGINE HAS STARTED, TAXI AWAY FROM THE FIRE AS QUICKLY AS POSSIBLE. IF A FIRE IS ON THE GROUND BUT ENGINE HAS NOT STARTED, ABANDON THE AIRPLANE IMMEDIATELY.

In either case, have the aircraft inspected thoroughly by a qualified mechanic to ensure that it is airworthy prior to any further flights.

3.4.2 ENGINE FAILURE DURING TAKEOFF

If an engine failure occurs prior to lifting off, the pilot must ensure he/she maintains control of the aircraft and comes to a stop on the remainder of the runway. The items in the checklist are listed to provide added safety after a failure of this type.

If engine power is lost after lift-off, the first response must be to lower the nose to maintain airspeed. In most cases, the landing should be straight ahead with only small changes in direction to avoid obstacles. There is seldom enough altitude and airspeed to execute a 180° gliding turn to the runway- in a turn, the glide angle is considerably steeper and stall speed substantially higher (at 60° bank, the stall speed is 75 mph or 65 knots IAS, flaps up).

If the aircraft is high enough to attempt to re-start the engine, above all, maintain a safe airspeed. Ensure that the fuel selector is in the BOTH position, the mixture RICH.

If the engine failure was caused by fuel exhaustion due to the selector being on an empty tank, power will not be restored until the air in the fuel lines is flushed out, and this may take a few seconds.

3.4.3 TOTAL LOSS OF ENGINE POWER IN FLIGHT

If the engine loses power, whether this is a total or a partial loss of power or if the engine runs roughly, the most important thing to do is to continue flying the aircraft, maintaining a safe airspeed. Trim the aircraft as required. In case of a total loss of power, the best glide speed is 68 mph or 59 knots (IAS) with flaps up.

The CC18-180 will glide 1.2 nautical miles for every 1000 feet of altitude loss. The rate of descent will be approximately 820 feet per minute. Most GPS devices have a "Direct to" function that shows the closest airports. Use charts to assess the topography of airports in the immediate vicinity.

If there is enough altitude, try to determine the cause of failure. In most cases, the reason is fuel exhaustion due to the selector being on an empty tank. Switching to the BOTH position or to the opposite tank causes fuel to feed to the engine. However, power will not be restored until the air in the fuel lines is flushed out, and this may take a few seconds.

Another common cause of engine failure is carburetor ice. An excessively rich air/fuel mixture may have cooled the engine to the point where there may not be sufficient hot air in the engine compartment to melt the accumulation of carburetor ice, even when the carburetor heat control is in the full "hot" position. At this point, the engine will cease to develop enough power to maintain airspeed and altitude. It is of the utmost importance that the guidelines concerning the use of the carburetor heat given in paragraph 7.5.7 (Air induction system) of this manual be followed closely.

**3.4.4 EMERGENCY LANDING WITHOUT ENGINE
POWER**

When you have located a suitable field, establish a spiral pattern around this field. Try to be at 1,000 feet above the field at the downwind position, to make a normal approach. Plan your approach for landing at the midpoint of the runway; aim for the normal touchdown area only after gliding to the runway is assured.

Excess altitude may be lost by widening your pattern, using flaps or slipping, or by using a combination of these techniques.

If possible, transmit a MAYDAY message on 121.5 MHz stating location and intentions. Squawk 7700 and activate the ELT.

Once the landing site is secure and you are committed to land, apply flaps and reduce speed to 52 mph or 45 knots (IAS). Close the throttle, move the mixture control to idle cut-off, shut off the ignition switch, turn the fuel selector to off and turn off the master switch.

WARNING
**BE EXTREMELY CAUTIOUS WHEN MANEUVERING
FOR LANDING AT LOW ALTITUDES. MAINTAIN A
SAFE MARGIN ABOVE STALL SPEED. SEE FIGURE
5-2 FOR STALL SPEED VS. ANGLE OF BANK.**

NOTE
With the master switch off, the instrument, landing and navigation lights will not operate.

If the landing site is very rough, there is a possibility that the aircraft may come to rest inverted. Should this occur, once the aircraft has come to a stop, open the cabin door (if you have not already done so). If the doors are jammed, or if there is no clear path to leave the aircraft on the right side, it is relatively easy to push out the windows on the left side. Protect your head with one arm and release the seat harness with the other. Exit the aircraft through the doors or the windows.

Once the risk of fire has passed, ensure that the Emergency Locator Transmitter has been activated. If battery power is available, it may be possible to transmit to passing aircraft using the aircraft's VHF radio.

3.4.5 PRECAUTIONARY LANDING WITH ENGINE POWER

A forced landing with engine power should be treated in the same way as described in the previous section. Bear in mind that if the engine is not running correctly, it may fail at any time and it is advisable to have a contingency plan in mind.

3.4.6 FIRE IN FLIGHT

The presence of fire is noted through smoke, smell and heat in the cabin. Electrical fires are often accompanied by an acrid smell of burning insulation.

Engine fires are very rare. The procedures outlined in the checklist are very general and pilot judgment should be the determining factor in the action to be taken. The maximum rate of descent may be obtained by diving the aircraft to 152 mph or 132 knots (IAS) and adjusting the throttle so as not to exceed 2700 RPM. Use extreme caution when flying at these limits and do not perform abrupt maneuvers (see Section 3.3.9).

It may be advisable to side slip the aircraft in case of an engine fire. This will direct the flames away from the fuselage. If there is an option as to which way to side slip, it is preferable to have the left wing up as the gascolator is on the lower left side of the firewall.

If the fire persists, conduct an emergency descent, land immediately and evacuate the aircraft.

3.4.7 LOSS OF OIL PRESSURE

More often than not, a loss of oil pressure will be gradual. If it is accompanied by an increase in oil temperature, it is a sign that there is a problem with the engine's oil system and the aircraft should be landed as soon as practical, as the engine may stop suddenly. At reduced power, maintain altitude and proceed to the nearest suitable landing site. Be prepared for a power-off forced landing.

Low oil pressure could be the result of a faulty gauge or sender unit or a malfunction in the oil pressure regulating system. In any case, land as soon as practical and have the problem investigated.

3.4.8 HIGH OIL TEMPERATURE

Abnormally high oil temperature indications may be caused by a variety of reasons, among them:

- Low Oil Level
- Obstruction in the air reaching the oil cooler
- Defective Gauge

A rapid rise in oil temperature must be treated seriously. Monitor the oil pressure gauge. Reduce power, enrich the mixture and, if practical, maintain a high airspeed to ram cooling air through the oil cooler.

Land as soon as practical and investigate the cause, but be prepared for a power-off forced landing.

3.4.9 EMERGENCY DESCENT

An Emergency Descent should be initiated whenever a situation occurs at high altitude requiring a high rate of descent. This is done in order to minimize exposure of the crew and passengers to an uncontrolled fire or when smoke, toxic fumes or other cause threatens control of the airplane through incapacitation or restricted visibility for the pilot (see paragraph, FIRE IN FLIGHT 3.4.6).

Retard throttle to Idle. Trim airplane for maximum allowed indicated airspeed appropriate to the configuration selected and the atmospheric conditions. Advise air traffic control if flight path is in an airway.

WARNING

IF DESCENT IS TO BE MADE USING FULL FLAPS, SLOW THE AIRPLANE TO 89 MPH OR 77 KNOTS IAS PRIOR TO FLAP EXTENSION AND PRIOR TO STARTING THE DESCENT. EXCEEDING THE FLAP EXTENDED SPEED CAN CAUSE DAMAGE TO THE WING STRUCTURE AND POSSIBLE FAILURE OF THE FLAP ATTACHMENTS.

IF THE DESCENT IS TO BE MADE WITH THE FLAPS RETRACTED, DO NOT EXCEED 152 MPH OR 132 KNOTS IAS (IN SMOOTH AIR) OR 102 MPH OR 88 KNOTS IAS (IN ROUGH AIR). DO NOT MAKE FULL ABRUPT CONTROL MOVEMENTS ABOVE 102 MPH OR 88 KNOTS IAS. EXCEEDING THE NEVER EXCEED SPEED OR THE DESIGN AND OPERATING SPEEDS CAN CAUSE SEVERE DAMAGE TO AND POSSIBLY FAILURE OF THE AIRPLANE STRUCTURE.

3.4.10 ALTERNATOR FAILURE

Alternator output failure can be caused by a mechanical failure of the alternator, a momentary over voltage condition, a failed alternator drive belt or other reasons.

A zero or negative reading on the ammeter may indicate alternator output failure and the discharge light will illuminate when the voltage drops below 12.6 volts. The alternator circuit breaker may trip. Failure of the alternator drive belt or a mechanical failure of the alternator may be accompanied by unusual sounds emanating from the engine compartment, possibly accompanied by a hot, rubber-like odor.

The first step is to reduce the electrical load to minimum. If the ammeter reading is positive, the alternator is delivering electrical power. If the ammeter continues to give a negative reading, this is an indication that the alternator has failed.

Turn the battery master switch off. Check that all circuit breakers are in and wait for at least ten seconds. Turn the battery master switch on. Check that the ammeter shows a positive indication. If the alternator resumes operation, continue flight, monitor the ammeter and have the system checked after landing. If the alternator does not return on line, reduce electrical load to the minimum required for safe flight by switching off all non-essential systems. Maintain only the equipment required to provide information for safe flight. Land AS SOON AS IS PRACTICAL and conduct appropriate repairs.

CAUTION

Duration of the battery is dependent on the condition of the battery at the time of the failure and the electrical load being demanded.

3.4.11 OVERVOLTAGE

With the engine running, the alternator is capable of raising the bus voltage to dangerously high levels. The voltage regulator limits the bus voltage to between 13.5 and 15.3 volts. If the bus voltage rises above 15.3 volts, a bright red “High Volts” light will illuminate. If this condition occurs, the battery master switch must be turned off immediately.

Wait for at least a minute and switch master switch on and monitor the voltage to determine whether the regulator has reset itself. If the “High Volts” light comes on again, pull alternator and field circuit breakers and continue flight as failed alternator, determine what electrical equipment is essential to continue the flight and land as soon as practical. Battery power is the only source of electrical power. Anticipate complete electrical failure.

3.4.12 INADVERTENT SPIN

If an inadvertent spin is entered, close the throttle, neutralize the ailerons and apply full rudder opposite to the direction of the spin. Move the elevator control forward to break the stall after applying the rudder. When the rotation stops, neutralize the rudder, relax the forward pressure on the elevator control as required to smoothly regain level flight, and return to initial power setting. If the flaps were down, retract them once a safe speed has been attained. Ensure that the maximum flap speed is not exceeded.

CAUTION

This recovery procedure is applicable only when the aircraft is in a spin. Application of controls as described above during a stall or after the aircraft has stopped gyrating may cause the aircraft to enter into a spin.

3.4.13 INADVERTENT ICING ENCOUNTER

Icing conditions are very difficult to predict. Aviation Weather Service may predict light, moderate or severe icing conditions at certain locations and altitudes and no icing will be encountered. On the other hand, icing conditions may not be forecast and any of the above levels of icing may occur.

As indicated above, icing conditions can be encountered in areas and at altitudes where no icing is forecast. Under these conditions, immediate action must be taken to divert from the icing conditions. It may be possible to descend to a lower, warmer altitude or it may be necessary to return to an area where no icing is present.

NOTE

Ice is especially prevalent if flying in clouds or visible moisture. This aircraft is approved for VFR flight only.

If ice build-up becomes evident on the windshield, the lift struts, or if engine operation becomes rough, turn the pitot heat and carburetor heat on. If engine operation remains rough, adjust the mixture control to obtain maximum smoothness. If engine operation continues to be rough, it may indicate that ice is accumulating on the propeller.

CAUTION

Ice accumulation on the wings and other airframe components will greatly increase the stall speed of the airplane and result in unpredictable flight characteristics.

Ice accumulation over engine induction air inlet can cause engine roughness and/or loss of power. Ice formations on the propeller may cause severe propeller/engine vibrations.

Ice accumulation over the pitot and/or static ports of the airspeed indicating system may cause erroneous airspeed altitude and VSI indications.

Ice build-up on the windshield will distort vision and probably obscure forward visibility.

TABLE OF CONTENTS

SECTION 4

NORMAL PROCEDURES

Paragraph	Page
4 NORMAL PROCEDURES	4-1
4.1 INTRODUCTION.....	4-1
4.2 AIRSPEEDS FOR NORMAL OPERATIONS	4-1
4.3 NORMAL PROCEDURES CHECKLIST	4-3
4.3.1 PREFLIGHT	4-3
4.3.1.1 Cockpit	4-3
4.3.1.2 Right Fuselage, Wing and Landing Gear.....	4-4
4.3.1.3 Nose Section.....	4-5
4.3.1.4 Left Fuselage, Wing and Landing Gear	4-6
4.3.1.5 Empennage.....	4-7
4.3.1.6 General	4-7
4.3.2 STARTUP AND TAXI.....	4-7
4.3.2.1 Before Starting Engine.....	4-7
4.3.2.2 Starting Engine.....	4-8
4.3.2.3 Starting Engine When Flooded.....	4-8
4.3.2.4 Warm Up	4-9
4.3.2.5 Taxiing.....	4-9
4.3.3 FLIGHT	4-9
4.3.3.1 Before Takeoff.....	4-9
4.3.3.2 Takeoff	4-10
4.3.3.3 Climb	4-10
4.3.3.4 Cruise.....	4-10
4.3.3.5 Descent	4-10
4.3.3.6 Approach and Landing.....	4-11
4.3.3.7 Balked Landing (Go-Around)	4-12
4.3.3.8 Stopping Engine.....	4-12
4.4 AMPLIFIED NORMAL PROCEDURES	4-13
4.4.1 PREFLIGHT	4-13
4.4.1.1 Cockpit	4-13
4.4.1.2 Right Fuselage, Wing and Landing Gear.....	4-14
4.4.1.3 Nose Section.....	4-15
4.4.1.4 Left Fuselage, Wing and Landing Gear	4-15
4.4.1.5 Empennage.....	4-15
4.4.2 STARTUP AND TAXI.....	4-16

**SECTION 4
NORMAL PROCEDURES**

**CUB CRAFTERS
CC18-180**

4.4.2.1	Before Starting Engine	4-16
4.4.2.2	Starting Engine	4-16
4.4.2.3	Starting Engine When Flooded	4-16
4.4.2.4	Warm Up	4-17
4.4.2.5	Taxiing	4-17
4.4.3	FLIGHT	4-18
4.4.3.1	Before Takeoff	4-18
4.4.3.2	Takeoff	4-19
4.4.3.3	Climb.....	4-19
4.4.3.4	Cruise	4-20
4.4.3.5	Descent	4-20
4.4.3.6	Approach and Landing	4-21
4.4.3.7	Balked Landing (Go-Around).....	4-22
4.4.3.8	Stopping Engine	4-22

4 NORMAL PROCEDURES

4.1 INTRODUCTION

This section describes the procedures that Cub Crafters recommends for the pilot to follow during normal operations of the CC18-180. It is divided into two parts. The first has abbreviated checklists; these are in a format suitable for reference in the cockpit. The second part amplifies the information given in the checklists. It provides the pilot with detailed descriptions that will help him/her understand the procedures and techniques.

This manual assumes that the pilot is appropriately rated in aircraft with tail wheel landing gear configurations.

4.2 AIRSPEEDS FOR NORMAL OPERATIONS

The speeds in this section are based on a maximum weight of 2300 lb., under standard conditions, at sea level.

INDICATED AIRSPEED (IAS)	MPH	KTS
Never Exceed Speed (V_{NE})	152	132
Operating Maneuvering Speed (V_O)	102	88
Maximum Flap Speed (V_{FE}) - Flaps 50°	89	77
Best Rate of Climb (V_Y)	74	64
Best Angle of Climb Speed (V_X)	60	52

Maximum demonstrated crosswind velocity 11 KTS

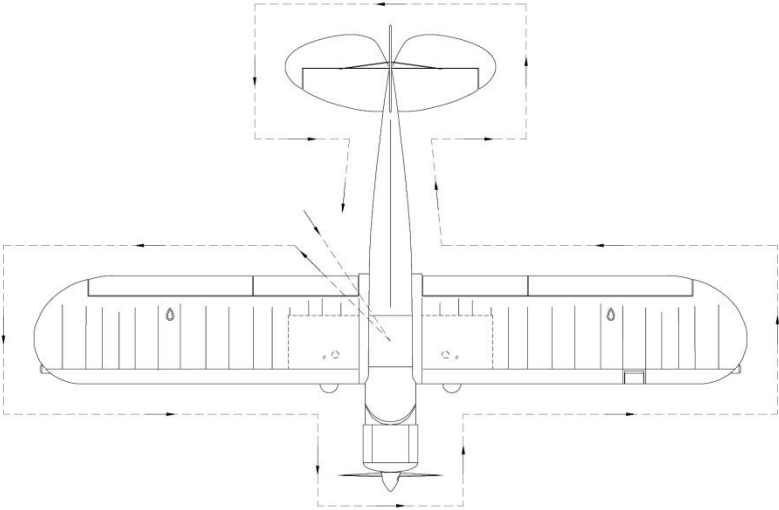


Figure 4-1 - Walk Around

4.3 NORMAL PROCEDURES CHECKLIST

4.3.1 PREFLIGHT

4.3.1.1 Cockpit

- Flight Controls Free and correct operation
- Trim Check operation and set for takeoff
- Fuel Selector Both
- Flaps Proper operation
- Fuel Gauges Sufficient fuel for intended flight
- Mixture Idle cut-off
- Carburetor Heat Off
- Magnetos Off
- Electrical Switches Off
- Master Switch On
- Navigation/Strobe Lights Check operation
- Landing Lights Check operation
- Stall Warning Horn Check operation
- Circuit breakers Check in
- Master Switch Off
- Windows Clear
- Night visors For night operations
Installed, secure and do not interfere with controls
- Documentation Onboard
- If passenger seat unoccupied,
Passenger seat harness Secure

4.3.1.2 Right Fuselage, Wing and Landing Gear

- Right FuselageCheck
- Baggage DoorClosed
- Accessory DoorClosed
- Tank Sump Drain
- Flap Surface Check condition
- Flap HingesCheck
- Flap Actuator RodCheck
- Aileron Surface Check condition
- Aileron HingesCheck
- Aileron CablesCheck
- Wing Tip and LightCheck
- Stall Warning Vane Check condition
- Tie Down Remove
- Fuel VentCheck
- Fuel TankCheck supply and cap for security
- Vortex GeneratorsCheck
- Main Landing Gear Leg and StrutCheck
- Brakes and LinesCheck
- TireCheck
- Chocks Removed

4.3.1.3 Nose Section

- Right Static Port.....Clear
- Right Cowling Open
- Alternator Belt..... Check Condition and Tension
- Oil Quantity Check and cap secure
(min recommended 6 Qt or 5.7 liters)
- Engine Condition Check
- Right Cowling Close
- Air Filter Check
- Propeller and Spinner..... Check
- Air Inlets..... Check
- Left Cowling..... Open
- Engine Condition Check
- Left Cowling..... Close
- Fuel Strainer Drain
- Left Static Port.....Clear

4.3.1.4 Left Fuselage, Wing and Landing Gear

- Chocks Removed
- Tire Check
- Brakes and Lines Check
- Main Landing Gear Leg and Strut Check
- Fuel Tank Check supply and cap for security
- Vortex Generators Check
- Fuel Vent Check
- Tie Down Remove
- Landing Light Check condition
- Pitot Tube Check condition
- Wing Tip and Light Check condition
- Aileron Hinges Check
- Aileron Surface Check condition
- Aileron Cables Check
- Flap Hinges Check
- Flap Surface Check condition
- Flap Actuator Rod Check
- Tank Sump Drain
- Left Fuselage Check

4.3.1.5 Empennage

- Bracing Wires Check for tension
- Hinges Check
- Surfaces Check
- Tail Wheel and Springs Check
- Tie Down Remove

4.3.1.6 General

Check that all wings and other external surfaces are free from frost, ice, snow.

4.3.2 STARTUP AND TAXI

4.3.2.1 Before Starting Engine

- Preflight Inspection Complete
- Pilot Seat Adjusted
- Seat Belts Fastened
- Passenger Briefing Complete
- Parking Brake Both wheels, set
- Door Closed
- Fuel Selector Both
- Avionics Master Switch Off
- Propeller Area Clear

4.3.2.2 Starting Engine

- Battery Master Switch On
- Beacon On
- Ignition Switch Both
- Mixture Full rich
- Primer Apply*
- Throttle Open 1/2 inch
- Starter Engage

After engine has started,

- Oil pressure Check
- Throttle Set 1000 RPM
- Lights As required
- Avionics master switch On

*Normal procedure 3 times. If engine is hot, omit this step.

WARNING
Ensure that the primer is closed and locked after the engine has started. Applying the primer with the engine running will make the engine stop.

4.3.2.3 Starting Engine When Flooded

- Ignition Switch Both
- Mixture Idle cut-off
- Throttle Full open
- Starter Engage

When engine fires,

- Mixture Rich
- Throttle Retard to 1000 RPM
- Oil Pressure Check
- Lights As required
- Avionics master switch On

4.3.2.4 Warm Up

- Throttle 1000 to 1200 RPM

4.3.2.5 Taxiing

- Parking Brakes Release
- Taxi Area Clear
- Throttle Apply slowly
- Brakes Check
- Steering Check
- Pitot Heat (if required) On

4.3.3 FLIGHT

4.3.3.1 Before Takeoff

- Parking Brake Set
- Throttle 1700 RPM*
- Magnetos Check
Drop not to exceed 175 RPM or 50 RPM differential
between magnetos and no engine roughness.
- Carburetor Heat Hot, note RPM drop, cold
- Engine Instruments Check
- Ammeter Check
- Throttle Check idle
- Throttle 1000 RPM
- Flight Instruments Check
- Fuel Selector Both
- Fuel Quantity Sufficient for intended flight
- Engine Instruments Check
- Mixture Set*
- Magnetos Both
- Carburetor Heat Off
- Primer In and locked
- Trim Set
- Flaps First notch (takeoff 22°)
- Controls Free and correct movement
- Doors Closed

- Strobes..... As required
- Transponder and Other Avionics On
- Seat Belts..... Check fastened
- Parking Brakes.....Release

* When operating at high altitudes and/or temperatures, it may be necessary to lean the mixture for peak RPM.

4.3.3.2 Takeoff

- Accelerate to 58 MPH or 50 KTS IAS (depending on aircraft weight) allowing tail to rise.
- Control Stick.....Gentle back pressure
- Accelerate to desired climb speed
- Flaps Retract
- Landing Lights (if applicable) Off

4.3.3.3 Climb

INDICATED AIRSPEED (IAS)	MPH	KTS
• Best Rate	74	64
• Best Angle	60	52

- Mixture.....Rich
Above 3000' LEAN to obtain maximum RPM
- Carburetor Heat..... As required

4.3.3.4 Cruise

- Power Adjust
- Mixture Adjust
- Carburetor Heat As required

4.3.3.5 Descent

- Power Adjust
- Mixture Full rich below 3000'
- Carburetor Heat As required

4.3.3.6 Approach and Landing

4.3.3.6.1 Normal Landing

- Fuel Selector Both
- Seat Belts Fastened
- Mixture Set
- Flaps Set

INDICATED AIRSPEED (IAS)	MPH	KTS
Maximum Speed First Notch Flaps (22°)	98	85
Maximum Speed Full Flaps (50°)	89	77

- Trim As required
- Speed As required
(1.3 times full flaps stall speed at gross weight is 63 MPH or 55 KTS IAS)

4.3.3.6.2 Cross-Wind Landing

- Fuel Selector Both
- Seat Belts.....Fastened
- Mixture Set
- FlapsSet below white arc

INDICATED AIRSPEED (IAS)	MPH	KTS
Maximum Speed 1st Notch Flaps (22°)	98	85
Maximum Speed Full Flaps (50°)	89	77

- Trim..... As required
- Speed..... As required
(A higher speed than normal is recommended)
- Ailerons-Rudder On short final
Use ailerons to keep upwind wing low
Rudder to hold runway alignment
- TouchdownDo not touch down in a slip
- Landing Roll Use ailerons to keep upwind wing down, rudder and brakes to maintain directional control

4.3.3.7 Bailed Landing (Go-Around)

- Throttle Full power
- Airspeed Above.....54 MPH / 47 KTS
- Flaps Retract slowly
- Trim..... As required

4.3.3.8 Stopping Engine

- Parking Brakes..... Set
- Flaps Retract
- Electrical Equipment Off
- Avionics Master Switch Off
- Throttle Idle
- Mixture Idle cut-off
- Magnetos Off
- Master Switch Off

4.4 AMPLIFIED NORMAL PROCEDURES

4.4.1 PREFLIGHT

4.4.1.1 Cockpit

Enter the cockpit and operate the flight controls to ascertain that they operate freely in the correct sense. As a rule of thumb, if the stick is moved towards a control surface, that surface must go up.

It is good practice to set trim control to the takeoff position and the fuel selector to both at this point. Ensure that both operate smoothly.

Check the flaps by lowering them to the takeoff and landing positions and retracting them.

Ensure that there is enough fuel for the intended flight by checking the quantity gauges.

The mixture should be in the Idle/cut off position and the carburetor heat in the off (cold) position.

Ensure that the magnetos are off.

Check that all the electrical systems that will be used for flight operate as intended. To confirm that the stall warning is functioning correctly, with the master switch on, have someone gently operate the vane on the leading edge of the right wing. After operating the electrical system, make sure that all circuit breakers are in.

Check that the windows are clean and clear of frost or snow.

If the intended operation will entail flying at night, the night visors must be installed on both side windows, over the instrument panel and on the left side panel above the fuel selector. Section 7 of this AFM explains how to install the visors.

Ensure that all the documentation required for the flight is onboard. This includes charts, airworthiness certificate, registration certificate, aircraft flight manual, weight and balance data, etc.

If no passenger is being carried, secure the aft seat belts and harnesses.

4.4.1.2 Right Fuselage, Wing and Landing Gear

Exit the aircraft and check the general condition of the right side of the fuselage. Confirm that the baggage door and the accessory compartment doors are closed and secure.

Drain enough fuel from the right sump to ascertain that there is no water or other contaminants in the tank. Dispose of the drained fuel in an appropriate manner.

Check the flaps and ailerons for general condition. Pay particular attention to the hinges to make sure they are secure and the cotter pins are in place. Check the general condition of the wings, lift struts and tip. Ensure that all the vortex generators are in place. If one should be missing, there will be a mark on the paint of the wing where it should have been. As you walk to the leading edge of the wing, look out for dents; ensure that the tie downs have been removed and gently operate the stall-warning vane. The fuel drain must be clear. Check the fuel cap by standing on the step provided on the landing gear. Inspect the landing gear, tires, brakes and shock absorber for condition and remove any chocks from under the wheel.

4.4.1.3 Nose Section

There are two ports for the static system, located just behind the engine compartment. Ensure that the one on the right side is clear. Open the right cowling and check the oil for quantity. Maximum capacity is 8 U.S. quarts (7.6 liters) and the minimum is 2 U.S. quarts (1.9 liters). However, it is strongly recommended the engine should not be operated below 6 U.S. quarts (5.7 liters). Ensure the oil filler cap is secure. Do not over-tighten, especially when the engine is hot. Check the general condition of the engine, paying special attention to the exhaust and muffler, security of throttle and mixture controls and make sure that there are no apparent leaks of fluids or gases. Close and latch the cowling.

As you make your way around the forward part of the aircraft, inspect the propeller for nicks and the spinner for security and cracks.

4.4.1.4 Left Fuselage, Wing and Landing Gear

Open the left cowl and repeat the inspection done on the right side. Close the cowling and drain fuel from the fuel strainer on the lower left side of the firewall, ensuring that there is no water or other contaminants. Dispose of the fuel in an appropriate manner. Repeat the procedure carried out on the right wing, fuselage side and landing gear.

4.4.1.5 Empennage

Check the tail surfaces for general condition and the tail wire bracing for security and tension. The hinges should be secured with cotter pins. Check the condition of the tail wheel and the springs. Check the rudder cable for condition and proper attachment. Check the condition of the tail wheel and springs. Remove the tie down.

4.4.2 STARTUP AND TAXI

4.4.2.1 Before Starting Engine

Adjust the seat using the lever on the left side of the seat-base. Seat belts should be fastened and the passenger briefed. Close the door. Engage the parking brakes, ensure that the fuel selector is in the BOTH position, verify that the avionics master switch is off and ensure that the propeller area is clear.

4.4.2.2 Starting Engine

Turn the battery master switch on. Switch the beacon on. Switch both magnetos on. Push the mixture control in to full rich. If the engine is cold, it may be desirable to prime the engine. To do this, rotate the primer control until it unlocks, pull it out and push it in, normally three times (more priming may be required in colder weather). After priming, make sure that the control is locked. Open the throttle 1/4 inch. Verify that the propeller area is clear and engage the starter. Oil pressure should rise within 30 seconds; otherwise shut the engine down. Turn on any lights that may be required. The avionics master switch may now be switched on and the radios tuned as necessary.

4.4.2.3 Starting Engine When Flooded

The throttle should be in the full open position. Turn the battery master switch on. Switch both magnetos on. The mixture control should be in the idle cut-off position. Verify that the propeller area is clear and engage the starter. As soon as the engine fires, move the mixture control to the rich position and reduce the throttle. Oil pressure should rise within 30 seconds; otherwise shut the engine down.

4.4.2.4 Warm Up

Textron Lycoming recommends that before takeoff, the engine should be warmed up for 2 to 3 minutes, although longer may be required when the temperatures are below freezing. The engine is warm enough when it idles at around 600 RPM and accelerates smoothly.

Avoid running the engine at idle for too long as it will tend to foul the spark plugs.

If you need to add power over loose stones or gravel, do so carefully to avoid damaging the propeller.

4.4.2.5 Taxiing

Before starting to taxi, make sure that the propeller blast will not affect the area behind the aircraft and that there are no unapproved people close to the aircraft.

Apply power and keep the elevator control stick back at all times. Apply both brakes and steer from side to side to make sure the aircraft is controllable on the ground.

In very cold weather conditions, it may be advisable to use the pitot heat.

4.4.3 FLIGHT

4.4.3.1 Before Takeoff

When the run-up area is reached, set the parking brakes. Perform the magneto check at 1700 RPM, as follows:

- Turn the ignition switch from both to the left magneto “L” and note the RPM drop. Turn the switch back to Both.
- Turn the ignition switch from both to the right magneto “R” and note the RPM drop. Turn the switch back to Both.

The RPM drop should not exceed 175 RPM on either magneto or show greater than a 50 RPM difference between magnetos. The engine should run smoothly on either magneto. If there is no drop in RPM, there may be a fault in the system and it should be checked. Do not run the engine on one magneto for longer than 10 seconds. If both magnetos are switched off while the engine is running, do not turn them back on. Cut the mixture and re-start the engine. If the magnetos are turned back on while the engine is running, damage may be done to the exhaust system and the engine should be inspected prior to flight.

Apply the carburetor heat to be sure that it is operating. You will note a drop of about 75 RPM when it is selected. This will also clear any ice that may have formed during taxiing. Bear in mind that when the carburetor heat is selected, unfiltered air is entering the engine, its use on the ground should be kept to a minimum.

The presence of ice may be recognized by the fact that the engine may momentarily run roughly when the carburetor heat is applied. This may be followed by an increase in RPM. When the carburetor heat is removed, the RPM may increase beyond 1700 RPM.

Check all engine parameters. Apply an electrical load (for example, by switching on the pitot heat) and observe that there is an increase in the electrical current drawn from the alternator.

Retard the throttle to idle to verify that the engine runs smoothly at minimum RPM (at least 600 RPM). Advance it to 1000 RPM.

In hot and high conditions, especially above 3,000 feet, it is important to lean the mixture prior to the magneto check. To do this, apply full power. Slowly lean the mixture until you observe the peak RPM. Retard the throttle slowly and proceed with the rest of the run-up.

Prior to takeoff, verify that the flight instruments operate correctly. Ensure that the fuel selector is on BOTH, the mixture is set, carburetor heat in the cold position and trim adjusted for takeoff. Engine gauges should be in the normal ranges. Flaps should be selected for takeoff; first notch (22°) is recommended. The door should be closed and seat belts fastened.

4.4.3.2 Takeoff

4.4.3.2.1 Normal Takeoff

The normal takeoff technique uses the first notch (22°) of flaps. Align on the runway and open the throttle. With the elevator in neutral, allow the tail to come up. At about 58 MPH or 50 KTS IAS, apply back pressure on the stick until the aircraft leaves the runway.

4.4.3.3 Climb

The best rate of climb speed at gross weight is 74 MPH or 64 KTS IAS and best angle is at 60 MPH or 52 KTS IAS, with flaps up. At lower weights, these speeds will be reduced.

Normal en-route climbs should be carried out at 80 to 90 MPH or 70 to 78 KTS IAS. At above 3000 feet, begin to lean the mixture. Consider the use of carburetor heat if weather conditions that may produce carburetor icing prevail.

4.4.3.4 Cruise

Once cruising altitude is reached, set the power. Normal cruising is performed between 55% and 80% power. As the aircraft accelerates, RPM will increase. Do not exceed 2700 RPM. Reduce the power to the selected setting and adjust the mixture. This may be accomplished using an EGT gauge. If one is installed, its operation manual will be found in Section 9. Otherwise, the engine may be leaned by slowly pulling the mixture back until there is a drop in RPM or the engine runs roughly. At this point, advance the mixture slightly (about 1/8") or until the engine runs smoothly.

NOTE

With a new engine, try to use 75% power as often as possible until either a total of 50 hours of operations have been accumulated or the oil consumption has stabilized. This will ensure that the piston rings seat correctly.

4.4.3.5 Descent

During descent, use the carburetor heat as required. Take care not to exceed the maximum speed of the engine (2700 RPM).

4.4.3.6 Approach and Landing

Flaps may be lowered to the first notch (22°) when the airspeed is below 98 MPH or 85 KTS IAS. The maximum speed for full flaps (50°) is 89 MPH or 77 KTS IAS.

CAUTION

Plan the pattern so that steep turns are not required when turning from down-wind to base leg and from base leg to final. Steep turns increase stall speed (Figure 5-2 and 5-3, Stall Speed vs. Angle of Bank). Steep turns, low power and slow airspeed can be dangerous, particularly if the airplane is heavily loaded and/or with gusty or turbulent wind conditions.

4.4.3.6.1 Normal Landing

The normal landing in the CC18-180 is in a three-point stalled condition. Adjust throttle and pitch attitude to compensate for ground effect as the aircraft approaches the runway. At approximately 10 feet AGL, smoothly begin landing flare to attain a three-point attitude. Maintain this attitude and adjust the throttle to accomplish a smooth touchdown. Gradually bring the stick back, keeping it back throughout the landing roll; maintain directional control with rudder and differential braking, as necessary.

It is possible to settle the aircraft on the ground at higher speeds in a two-point configuration. The landing flare is kept flat, aiming to place the main landing gear wheels on the runway at a minimum sink rate. When the wheels contact the ground, the stick must be moved forward to counteract the pitching up reaction of the aircraft. After the aircraft has slowed down, the tail may be brought down with the stick. Bear in mind that the rudder will begin to lose effectiveness as airspeed is reduced. Maintain directional control. Apply brakes as necessary.

4.4.3.6.2 Cross-Wind Landing

When established on a short final approach, use the ailerons and rudder to maintain the approach path. Lower the upwind wing using ailerons and use the rudder to hold runway alignment. At approximately 10 feet AGL, increase the pitch attitude to flare. Ensure that the aircraft is not in a slip when touching down. When a satisfactory touchdown has been accomplished, reduce the throttle to IDLE and adjust ailerons slightly to allow the downwind main wheel to touch down.

Maintain the stick deflected into the wind as necessary to keep the upwind wing from lifting, and use rudder and differential braking, as necessary, to maintain directional control. Once the three wheels are on the ground, move the stick all the way back and keep it there at all times, unless correcting for crosswind during the landing roll. Apply brakes only as required to maintain directional control, slow to taxi speed or stop.

NOTE

It is recommended that a slightly higher airspeed be used on final approach during gusty or turbulent wind conditions. Add approximately one (1) MPH or one (1) KTS IAS for each two (2) KTS of reported gust.

4.4.3.7 Balked Landing (Go-Around)

In a balked landing, apply full power. Slowly retract the flaps to the first notch (22°) and establish a positive rate of climb. Maintain climb speed. Trim as required.

4.4.3.8 Stopping Engine

The parking location should be free of loose material such as gravel, debris or unsecured tie down ropes, which could be blown up by the propeller.

When the aircraft is parked, turn off all electrical equipment, including avionics off. The engine must always be stopped by placing the mixture control in the idle cut-off position. Turn the magnetos off. Turn the battery master switch off.

After the airplane has been positioned, release the brakes and determine whether the airplane is likely to roll as the crew exits. If so, set the parking brake. Extend the flaps to prevent damage to the flaps and their operating mechanism in the event of strong winds from the tail direction.

Install wheel chocks if available. Tie down both the wing and the tail. Straps or ropes are preferred over chains. Tie-downs should be firmly secured but without excessive tension. Close cabin windows and doors.

INTENTIONALLY LEFT BLANK

TABLE OF CONTENTS

SECTION 5

PERFORMANCE

Paragraph	Page
5 PERFORMANCE	5-3
5.1 INTRODUCTION	5-3
5.2 PERFORMANCE CHARTS	5-5
5.2.1 AIRSPEED CALIBRATION	5-6
5.2.2 STALL SPEED	5-7
5.2.3 TAKE OFF	5-9
5.2.4 CLIMB RATE AND GRADIENT	5-13
5.2.5 CRUISE WITH SENSENICH PROPELLER	5-15
5.2.6 CRUISE WITH MCCAULEY PROPELLER	5-16
5.2.7 LANDING	5-17
5.2.8 BALKED LANDING	5-21
5.2.9 GLIDE	5-22
5.3 CONVERSION TABLES	5-23
5.3.1 WEIGHT	5-23
5.3.2 LENGTH	5-23
5.3.3 VOLUME	5-24
5.3.4 TEMPERATURE	5-25
5.3.5 TORQUE	5-25
5.3.6 SPEED	5-26
5.3.7 DISTANCE	5-26

INTENTIONALLY LEFT BLANK

5 PERFORMANCE

5.1 INTRODUCTION

The purpose of this section is to provide information that will assist the pilot with planning a flight in detail with reasonable accuracy.

All data has been corrected to I.C.A.O. standard day conditions. Where appropriate, the data has been expanded analytically for variations in weight, altitude, temperature, etc.

The data has been derived from actual flight tests, taking into account the proficiency of an average pilot. The pilot must use sound judgement when assessing the effect of conditions not found in the charts, such as soft runways and winds aloft. The parameters will be affected by the performance of the engine. Therefore, the pilot must be thoroughly familiar with its operation, including the procedures for adjusting the mixture control.

Data should not be extrapolated beyond the limits shown on the charts.

All information is presented in the units used on the aircraft's instrumentation. Conversion charts are available in Section 5.3.

- Airspeeds in statute miles per hour
- Weights in pounds
- Altitudes in feet
- Temperatures in degrees Fahrenheit
- Wind speed in nautical miles per hour (KTS)

The CC18-180 may be equipped with different tires and propellers (see next page).

1) PROPELLERS

MAKE	MODEL	MIN DIA	MAX DIA	PITCH RANGE
Sensenich Propeller Manufacturing Company, Inc.*	76EM8*	76	76	52-56
McCauley Propeller Systems	1A200/FA	78.8	82	40-44
Sensenich Wood Propeller Company, Inc. **	W80CM8 **	80	80	45-47

Table 5-1 - Approved Propellers

<p>NOTE</p> <p>* AD 69-09-03 applies when using the Sensenich Propeller 76EM8 with the Lycoming O-360-C1G engine.</p>
--

<p>NOTE</p> <p>** The Sensenich W80CM8 is NOT approved for aircraft certified in Canada.</p>

2) TIRES

- Goodyear 8.50 X 6-6
- Goodyear 26 x 10.5-6

The different combination of propellers and tires will affect the performance of the aircraft. Whenever performance information is published for only one configuration, it will correspond to the one that is the most critical. For example, the only charts provided for takeoff performance will apply to aircraft equipped with the Sensenich 76EM8 propeller. Takeoff distances with the McCauley propeller will be shorter.

5.2 PERFORMANCE CHARTS

Figure 5-1 Airspeed System Calibration 5-6

Figure 5-2 Stall Speed Versus Angle of Bank 5-7

Figure 5-3 Stall Speed Versus Angle of Bank 5-8

Figure 5-4 Takeoff Ground Distance at 2300 lb with
SENSENICH 76EM8 Propeller and 26”
Wheels 5-9

Figure 5-5 Takeoff Distance to 50’ Obstacle at 2300 lb
with SENSENICH 76EM8 Propeller and 26”
Wheels 5-11

Figure 5-6 Maximum Rate and Gradient of Climb at
2300 lb. with SENSENICH 76EM8 Propeller
and 26” Wheels 5-14

Figure 5-7 Cruise Speed..... 5-15

Figure 5-8 Cruise Speed..... 5-16

Figure 5-9 Landing Distance from 50’ Obstacle at 2300
lb. with SENSENICH 76EM8 Propeller and
26” Wheels 5-17

Figure 5-10 Landing Ground Distance at 2300 lb. with
SENSENICH 76EM8 Propeller and 26”
Wheels 5-19

Figure 5-11 Balked Landing Climb Gradient..... 5-21

Figure 5-12 Glide Performance 5-22

5.2.1 AIRSPEED CALIBRATION

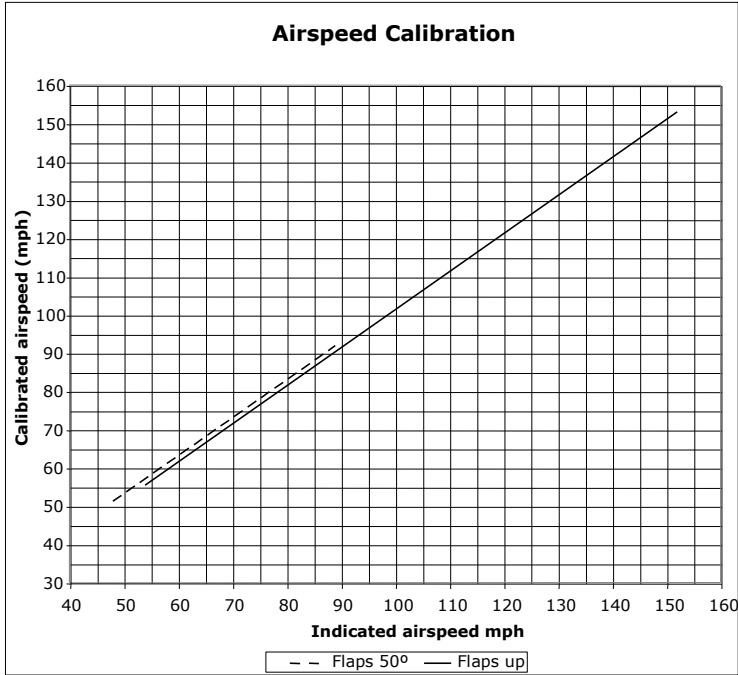


Figure 5-1 - Airspeed System Calibration

NOTE

Indicated airspeed assumes zero instrument error.

5.2.2 STALL SPEED

5.2.2.1 McCauley Propeller

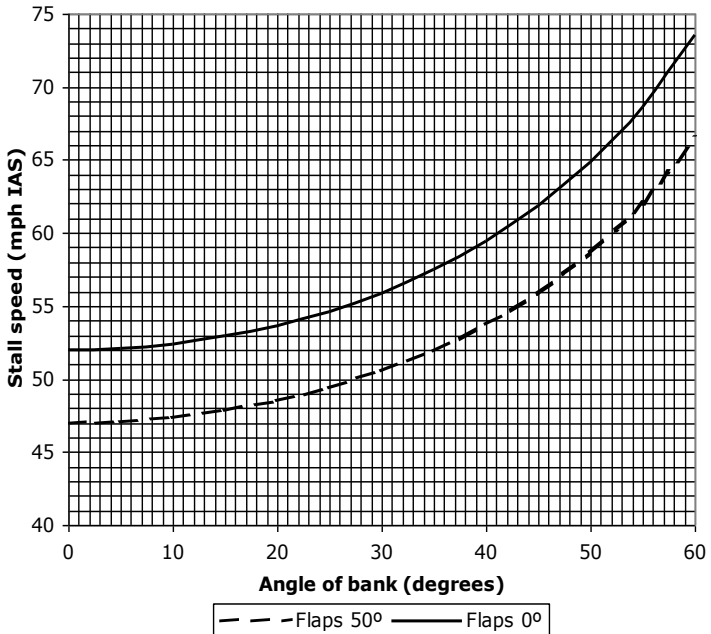


Figure 5-2 - Stall Speed Versus Angle of Bank

Configuration:

- McCauley Propeller Systems, model 1A200/FA, 82 in. diameter, 40 in. pitch
- Goodyear 26x10.5-6 Tires

5.2.2.2 Sensenich Propeller

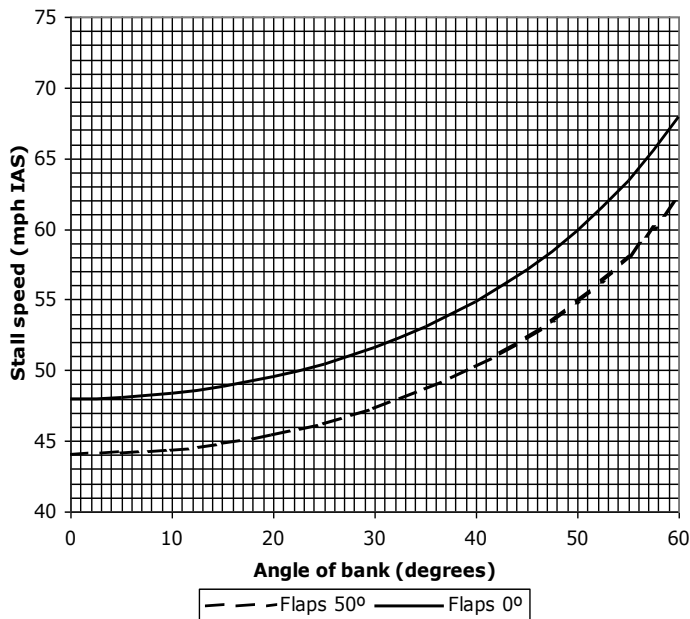


Figure 5-3 - Stall Speed Versus Angle of Bank

Configuration:

- Sensenich Propeller Manufacturing Company, Inc, model 76EM8, 76 in. diameter, 56 in. pitch
- Goodyear 26x10.5-6 Tires

5.2.3 TAKE OFF

5.2.3.1 Normal Takeoff: Sensenich Propeller

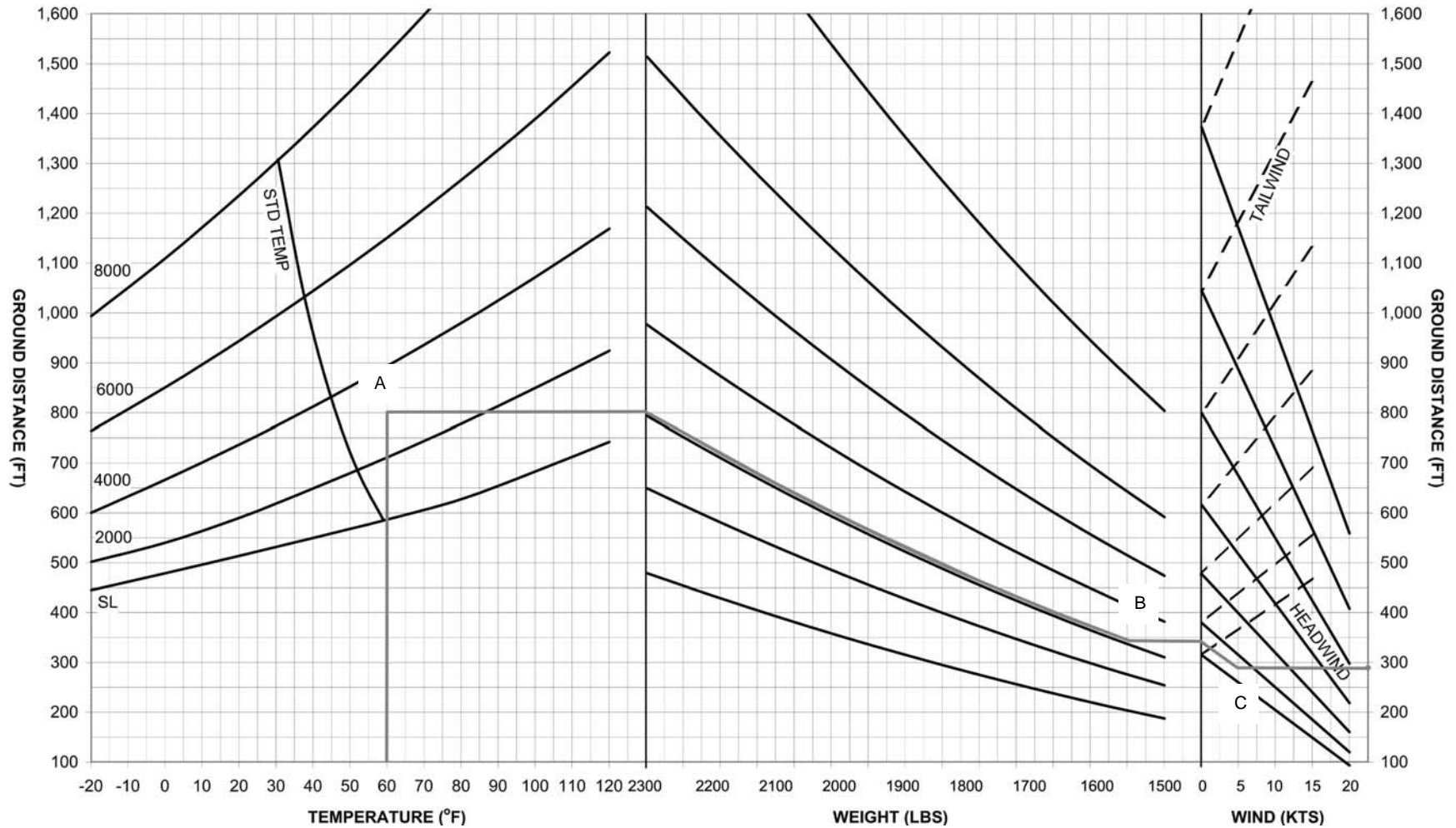


Figure 5-4 Takeoff Ground Distance at 2300 lbs. with SENSENICH 76EM8 Propeller and Goodyear 26" Tires

Example:
Takeoff conditions

Outside air temperature (OAT)	60°F
Pressure altitude at airport	3000 feet
Aircraft weight	1550 lbs.
Headwind	5 kts.

On the graph at the furthest left of the chart, identify point A where the OAT intersects with the pressure altitude at the airport. Note that the pressure altitude lines are the curved lines on the chart. 3000 ft. is found because it is half way between 2,000 and 4,000 ft.

Extend a line horizontally from point A to the reference line on the second graph (the one in the center). From there, follow parallel to the weight lines until you reach 1550 lbs. This is point B.

Extend a line horizontally from point B to the reference line on the graph on the right. From there, follow parallel to the wind lines until you reach 5 kts. This is point C.

From point C extend a line horizontally to the axis on the far right of the chart. This will give you the takeoff ground distance (approximately 290 ft.) under the conditions mentioned above, assuming a smooth runway with no appreciable slope.

5.2.3.2 50' Obstacle takeoff: Sensenich Propeller

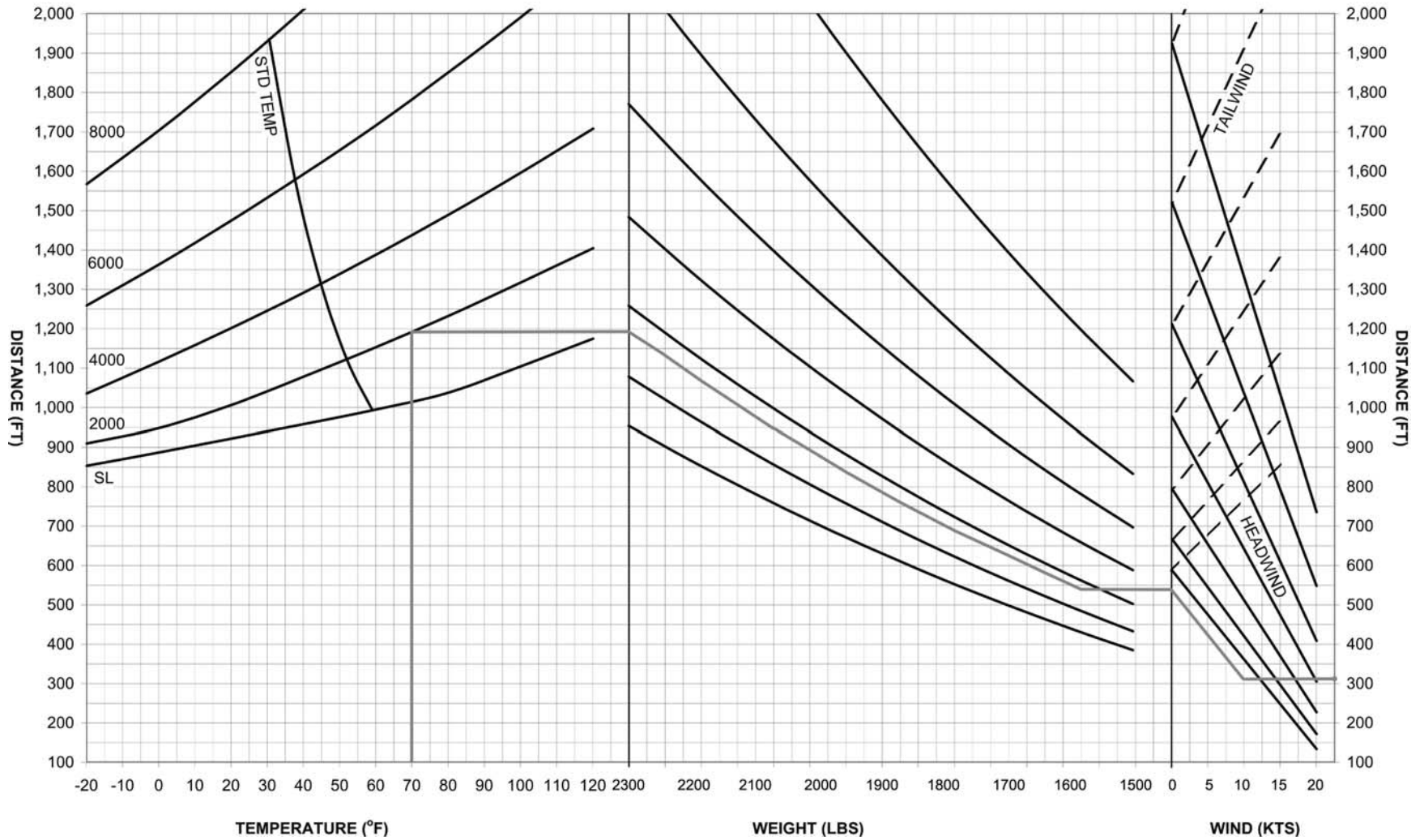


Figure 5-5 Takeoff Distance to 50' Obstacle at 2300 lb with SENSENICH 76EM8 Propeller and Goodyear 26" Tires

Example:

Takeoff conditions

Outside air temperature (OAT)	70°F
Pressure altitude at airport	2000 feet
Aircraft weight	1580 lbs.
Headwind	10 kts.

On the graph at the furthest left of the chart, identify point A where the OAT intersects with the pressure altitude at the airport. Note that the pressure altitude lines are the curved lines on the chart.

Extend a line horizontally from point A to the reference line on the second graph (the one in the center). From there, follow parallel to the weight lines until you reach 1580 lbs. This is point B.

Extend a line horizontally from point B to the reference line on the graph on the right. From there, follow parallel to the wind lines until you reach 10 kts. This is point C.

From point C extend a line horizontally to the axis on the far right of the chart. This will give you the total takeoff distance to clear a 50' obstacle (approximately 300 ft.) under the conditions mentioned above, assuming a smooth runway with no appreciable slope.

5.2.4 CLIMB RATE AND GRADIENT

Pressure Altitude (ft)	Correction for ISA	Airspeed (IAS)		OAT		Climb Gradient %	Rate of Climb (fpm)	
		MPH	KTS	°F	°C			
0	ISA-59°F (0°F)	74	64	0	-18	14%	919	
2000		73	63	-7	-22	13%	813	
4000		73	63	-14	-26	11%	707	
6000		72	63	-21	-29	9%	598	
8000		ISA-32.8°C (-17.8°C)	72	63	-29	-34	8%	494
10000			71	62	-36	-38	6%	387
12000			70	61	-43	-42	5%	280
14000			70	61	-50	-46	3%	172
0	ISA-27°F (32°F)		74	64	32	0	13%	858
2000		73	63	25	-4	12%	758	
4000		73	63	18	-8	10%	659	
6000		72	63	11	-12	9%	556	
8000		ISA-15°C (0°C)	72	63	3	-16	7%	459
6000			71	62	-4	-20	6%	359
12000			70	61	-11	-24	4%	259
14000			70	61	-18	-28	3%	159
0	ISA (59°F)		74	64	59	15	12%	797
2000		73	63	52	11	11%	703	
4000		73	63	45	7	10%	609	
6000		72	63	38	3	8%	515	
8000		ISA (15°C)	72	63	30	-1	7%	421
10000			71	62	23	-5	5%	327
12000			70	61	16	-9	4%	233
14000			70	61	9	-13	2%	139

(continued on next page)

**SECTION 5
PERFORMANCE**

**CUB CRAFTERS
CC18-180**

Pressure Altitude (ft)	Correction for ISA	Airspeed (IAS)		OAT		Climb Gradient %	Rate of Climb (fpm)
		MPH	KTS	°F	°C		
0	ISA+16°F (75°F) ISA+8.9°C (23.9°C)	74	64	75	24	12%	788
2000		73	63	68	20	11%	695
4000		73	63	61	16	9%	603
6000		72	63	54	12	8%	509
8000		72	63	46	8	7%	419
10000		71	62	39	4	5%	327
12000		70	61	32	0	4%	236
14000		70	61	25	-4	2%	144
0	ISA+41°F (100°F) ISA+22.8°C (37.8°C)	74	64	100	38	12%	752
2000		73	63	93	34	10%	663
4000		73	63	86	30	9%	575
6000		72	63	79	26	8%	485
8000		72	63	71	22	6%	399
6000		71	62	64	18	5%	311
12000		70	61	57	14	4%	224
14000		70	61	50	10	2%	136

Figure 5-6 - Maximum Rate and Gradient of Climb at 2300 lb. with SENSENICH 76EM8 Propeller and 26" Wheels

Configuration:

- Sensenich Propeller Manufacturing Company, Inc, model 76EM8, 76 in. diameter, 56 in. pitch
- Goodyear 26x10.5-6 Tires

NOTE
Mixture leaned for maximum RPM

5.2.5 CRUISE WITH SENSENICH PROPELLER

Pressure Altitude (ft)	RPM	Power %	TAS		Fuel Flow (GPH)
			MPH	KTS	
3000	2200	44%	94	82	6.1
	2300	52%	101	88	6.9
	2400	59%	108	94	7.7
	2500	67%	115	100	8.5
	2600	75%	122	106	9.4
	2700	82%	129	112	10.2
5000	2200	43%	94	82	5.8
	2300	50%	101	88	6.5
	2400	57%	108	94	7.3
	2500	65%	115	100	8.0
	2600	72%	122	106	8.8
	2700	79%	129	112	9.6
7000	2200	43%	90	78	5.5
	2300	49%	98	85	6.3
	2400	56%	105	91	7.1
	2500	62%	112	97	7.9
	2600	68%	120	104	8.7
	2700	75%	127	110	9.5
9000	2200	42%	88	77	5.1
	2300	47%	96	83	5.9
	2400	53%	104	90	6.8
	2500	59%	112	97	7.6
	2600	65%	120	104	8.4
	2700	70%	128	111	9.3

Figure 5-7 - Cruise Speed

Configuration:

- Sensenich Propeller Manufacturing Company, Inc, model 76EM8, 76 in. diameter, 56 in. pitch
- Goodyear 26x10.5-6 Tires

NOTE
Mixture leaned for maximum RPM

5.2.6 CRUISE WITH MCCAULEY PROPELLER

Pressure Altitude (ft)	RPM	Power %	TAS		Fuel Flow (GPH)
			MPH	KTS	
3000	2400	56%	96	83	7.1
	2500	64%	103	90	7.8
	2600	71%	109	95	8.6
	2700	78%	115	100	9.4
5000	2400	54%	94	82	7.0
	2500	61%	101	88	7.6
	2600	68%	109	85	8.3
	2700	75%	116	101	9.0
7000	2400	53%	92	80	6.5
	2500	58%	99	86	7.1
	2600	64%	107	93	7.8
	2700	70%	115	100	8.4
9000	2400	50%	89	77	6.1
	2500	56%	97	84	6.7
	2600	61%	104	90	7.3
	2700	66%	112	97	8.0

Figure 5-8 - Cruise Speed

Configuration:

- McCauley Propeller Systems, model 1A200/FA, 82 in. diameter, 40 in. pitch
- Goodyear 26x10.5-6 Tires

NOTE
Mixture leaned for maximum RPM.

5.2.6 LANDING

5.2.6.1 Normal Landing

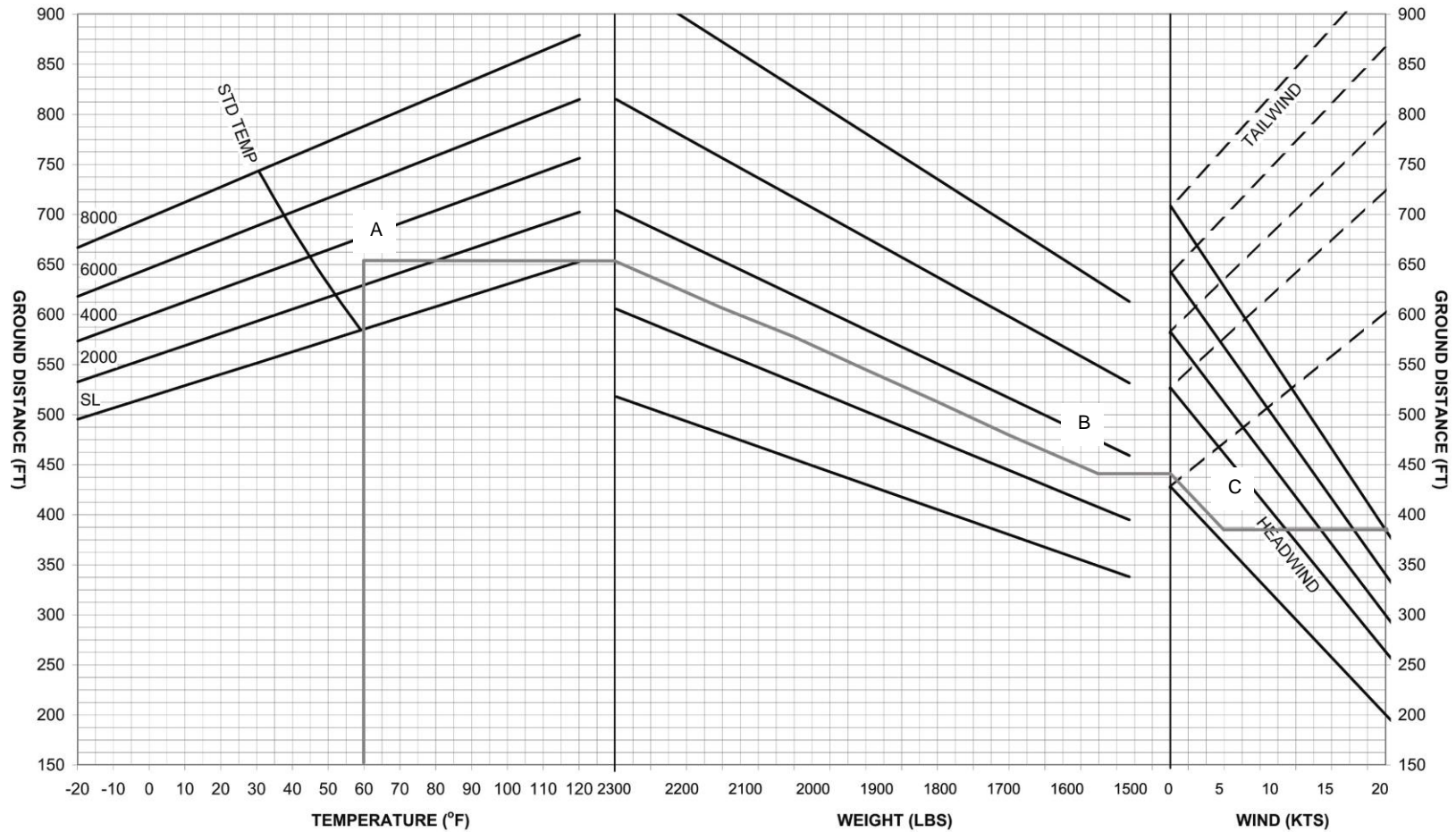


Figure 5-10 Landing Ground Distance at 2300 lb with SENSENICH 76EM8 Propeller and 26" Wheels

Example:
Landing conditions

Outside air temperature (OAT)	60°F
Pressure altitude at airport	3000 feet
Aircraft weight	1550 lbs.
Headwind	7 kts.

On the graph at the furthest left of the chart, identify point A where the OAT intersects with the pressure altitude at the airport. Note that the pressure altitude lines are the curved lines on the chart. 3000 ft. is found because it is half way between 2,000 and 4,000 ft.

Extend a line horizontally from point A to the reference line on the second graph (the one in the center). From there, follow parallel to the weight lines until you reach 1550 lbs. This is point B.

Extend a line horizontally from point B to the reference line on the graph on the right. From there, follow parallel to the wind lines until you reach 5 kts. This is point C.

From point C extend a line horizontally to the axis on the far right of the chart. This will give you the takeoff ground distance (approximately 380 ft.) under the conditions mentioned above, assuming a smooth runway with no appreciable slope.

5.2.6.2 Landing over 50' obstacle

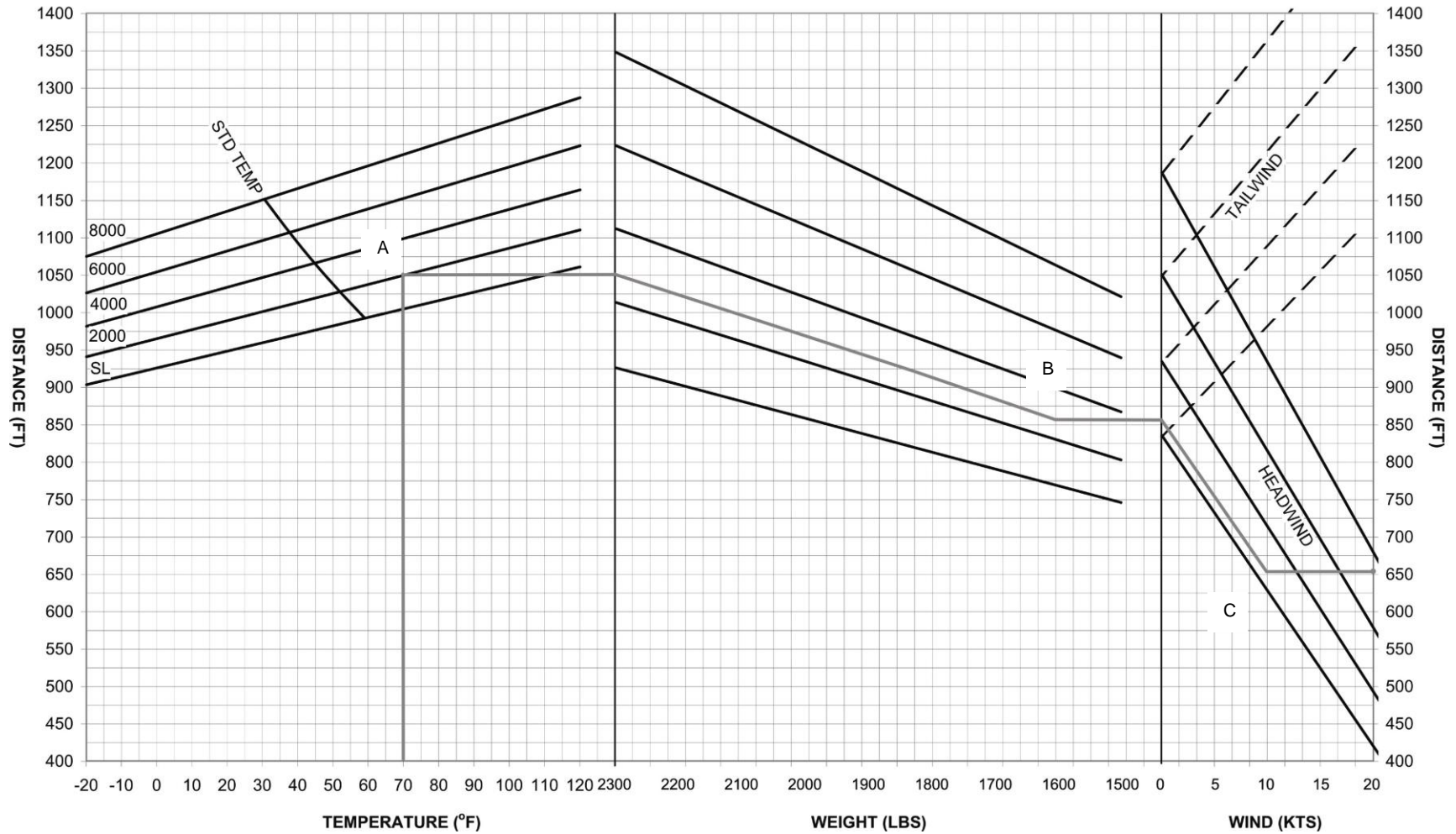


Figure 5-9 Landing Distance over 50' Obstacle at 2300 lb with SENSENICH 76EM8 Propeller and 26" Wheels

Example:
Landing conditions

Outside air temperature (OAT)	70°F
Pressure altitude at airport	2000 feet
Aircraft weight	1600 lbs.
Headwind	10 kts.

On the graph at the furthest left of the chart, identify point A where the OAT intersects with the pressure altitude at the airport. Note that the pressure altitude lines are the curved lines on the chart. Extend a line horizontally from point A to the reference line on the second graph (the one in the center). From there, follow parallel to the weight lines until you reach 1600 lbs. This is point B.

Extend a line horizontally from point B to the reference line on the graph on the right. From there, follow parallel to the wind lines until you reach 10 kts. This is point C.

From point C extend a line horizontally to the axis on the far right of the chart. This will give you the total takeoff distance to clear a 50' obstacle (approximately 650 ft.) under the conditions mentioned above, assuming a smooth runway with no appreciable slope.

5.2.8 BALKED LANDING

Pressure altitude (ft)	Airspeed (IAS)		Climb gradient (%)
	MPH	KTS	
5,000	67	58	9.0

Figure 5-11 - Balked Landing Climb Gradient

NOTE

First notch flaps (22°)

Mixture leaned for peak RPM

Configuration:

- Sensenich Propeller Manufacturing Company, Inc, model 76EM8, 76 in. diameter, 56 in. pitch
- Goodyear 26x10.5-6 Tires

5.2.9 GLIDE

Statute miles	Nautical miles	Altitude loss (feet)
1.4	1.2	1000
2.8	2.4	2000
4.1	3.6	3000
5.5	4.8	4000
6.9	6.0	5000
8.3	7.2	6000
9.7	8.4	7000
11.1	9.6	8000
12.4	10.8	9000
13.8	12.0	10000
15.2	13.2	11000
16.6	14.4	12000
18.0	15.6	13000
19.4	16.8	14000

Figure 5-12 - Glide Performance

NOTE

At 2300 lb. glide speed 68 MPH or 59 KTS, flaps up
Configuration:

- McCauley Propeller Systems, model 1A200/FA, 82 in. diameter, 40 in. pitch
- Goodyear 26x10.5-6 Tires

5.3 CONVERSION TABLES

5.3.1 WEIGHT

**POUNDS INTO KILOGRAMS
LIVRES EN KILOGRAMMES**

LB	+0	+1	+2	+3	+4	+5	+6	+7	+8	+9
	kg	kg	kg	kg	kg	kg	kg	kg	kg	kg
0		0.454	0.907	1.361	1.814	2.268	2.722	3.175	3.629	4.082
10	4.536	4.990	5.443	5.897	6.350	6.804	7.257	7.711	8.165	8.618
20	9.072	9.525	9.979	10.433	10.886	11.340	11.793	12.247	12.701	13.154
30	13.608	14.061	14.515	14.969	15.422	15.876	16.329	16.783	17.237	17.690
40	18.144	18.597	19.051	19.504	19.958	20.412	20.865	21.319	21.772	22.226
50	22.680	23.133	23.587	24.040	24.494	24.948	25.401	25.855	26.303	26.762
60	27.216	27.669	28.123	28.576	29.030	29.484	29.937	30.391	30.844	31.298
70	31.752	32.205	32.659	33.112	33.566	34.019	34.473	34.927	35.380	35.834
80	36.287	36.741	37.195	37.648	38.102	38.555	39.009	39.463	39.916	40.370
90	40.823	41.277	41.731	42.184	42.638	43.091	43.545	43.999	44.452	44.906
100	45.359	45.813	46.266	46.720	47.174	47.627	48.081	48.534	48.988	49.442

5.3.2 LENGTH

**FEET INTO METERS
PIEDS EN METRES**

Ft	+0	+1	+2	+3	+4	+5	+6	+7	+8	+9
	Meters	Meters	Meters	Meters	Meters	Meters	Meters	Meters	Meters	Meters
0		0.305	0.610	0.914	1.219	1.524	1.829	2.134	2.438	2.743
10	3.048	3.353	3.658	3.962	4.267	4.572	4.877	5.182	5.486	5.791
20	6.096	6.401	6.706	7.010	7.315	7.620	7.925	8.230	8.534	8.839
30	9.144	9.449	9.754	10.058	10.363	10.668	10.973	11.278	11.582	11.887
40	12.192	12.497	12.802	13.106	13.411	13.716	14.021	14.326	14.630	14.935
50	15.240	15.545	15.850	16.154	16.459	16.764	17.069	17.374	17.678	17.983
60	18.288	18.593	18.898	19.202	19.507	19.812	20.117	20.422	20.726	21.031
70	21.336	21.641	21.946	22.250	22.555	22.860	23.165	23.470	23.774	24.079
80	24.384	24.689	24.994	25.298	25.603	25.908	26.213	26.518	26.822	27.127
90	27.432	27.737	28.042	28.346	28.651	28.956	29.261	29.566	29.870	30.175
100	30.480	30.785	31.090	31.394	31.699	32.004	32.309	32.614	32.918	33.223

**SECTION 5
PERFORMANCE**

**CUB CRAFTERS
CC18-180**

**INCHES INTO CENTIMETERS
POUCES EN CENTIMETRES**

IN	+0	+1	+2	+3	+4	+5	+6	+7	+8	+9
	CM	CM	CM	CM	CM	CM	CM	CM	CM	CM
0		2.5	5.1	7.6	10.2	12.7	15.2	17.8	20.3	22.9
10	25.4	27.9	30.5	33.0	35.6	38.1	40.6	43.2	45.7	48.3
20	50.8	53.3	55.9	58.4	61.0	63.5	66.0	68.6	71.1	73.7
30	76.2	78.7	81.8	83.8	86.4	88.9	91.4	94.0	96.5	99.1
40	101.6	104.1	106.9	109.2	111.8	114.3	116.8	119.4	121.9	124.5
50	127.0	129.5	132.1	134.6	137.2	139.7	142.2	144.8	147.3	149.9
60	152.4	154.9	157.5	160.0	162.6	165.1	167.6	170.2	172.7	175.3
70	177.8	180.3	182.9	185.4	188.1	190.5	193.0	195.6	198.1	200.7
80	203.2	205.7	208.3	210.8	213.4	215.9	218.4	221.0	223.5	226.1
90	228.6	231.1	233.9	236.2	238.8	241.3	243.8	246.4	248.9	251.5
100	254.0	256.5	259.1	261.6	264.2	266.7	269.2	271.8	274.3	276.9

5.3.3 VOLUME

**GALLONS INTO LITERS
GALLONS EN LITRES**

Gal	+0	+1	+2	+3	+4	+5	+6	+7	+8	+9
	Liters	Liters	Liters	Liters	Liters	Liters	Liters	Liters	Liters	Liters
0		3.79	7.57	11.36	15.14	18.93	22.71	26.50	30.28	34.07
10	37.85	41.64	45.42	49.21	52.10	56.78	60.57	64.35	68.14	71.92
20	75.71	79.49	83.28	87.06	90.85	94.64	98.42	102.21	105.99	109.78
30	113.56	117.35	121.13	124.92	128.7	132.49	136.27	140.06	143.85	147.63
40	151.42	155.20	158.99	162.77	166.56	170.34	174.13	177.91	181.70	185.49
50	189.27	193.06	196.84	200.63	204.41	208.20	211.98	215.77	219.55	223.34
60	227.12	230.91	234.70	238.48	242.27	246.05	249.84	253.62	257.41	261.19
70	264.98	268.76	272.55	276.34	280.12	283.91	287.69	291.48	295.26	299.05
80	302.83	306.62	310.40	314.19	317.97	321.76	325.55	329.33	333.12	336.90
90	340.69	344.47	348.26	352.04	355.83	359.61	363.34	367.18	370.97	374.76
100	378.54	382.33	386.11	389.90	393.68	397.47	401.25	405.04	408.82	412.61

5.3.4 TEMPERATURE

**FAHRENHEIT INTO CELSIUS
FAHRENHEIT EN CELSIUS**

°F	+0	+1	+2	+3	+4	+5	+6	+7	+8	+9
	°C	°C	°C	°C	°C	°C	°C	°C	°C	°C
0		-17.20	-16.7	-16.10	-15.60	-15.00	-14.40	-13.90	-13.30	-12.80
10	-12.20	-11.70	-11.10	-10.60	-10.00	-9.44	-8.89	-8.33	-7.78	-7.22
20	-6.67	-6.11	-5.56	-5.00	-4.44	-3.89	-3.33	-2.78	-2.22	-1.67
30	-1.11	-0.56	0.00	0.56	1.11	1.67	2.22	2.78	3.33	3.89
40	4.44	5.00	5.56	6.11	6.67	7.22	7.78	8.33	8.89	9.44
50	10.00	10.60	11.10	11.70	12.00	12.80	13.30	13.90	14.40	15.00
60	15.60	16.10	16.70	17.20	17.80	18.30	18.90	19.40	20.00	20.60
70	21.10	21.70	22.20	22.80	23.30	23.90	24.40	25.00	25.60	26.10
80	26.70	27.20	27.80	28.30	28.90	29.40	30.00	30.60	31.10	31.70
90	32.20	32.80	33.30	33.90	34.40	35.00	35.60	36.10	36.70	37.20
100	37.80	38.30	38.90	39.40	40.00	40.60	41.10	41.70	42.20	42.80

5.3.5 TORQUE

INCH POUNDS INTO NEWTON METERS

In-lbs.	+0	+10	+20	+30	+40	+50	+60	+70	+80	+90
	N-m	N-m	N-m	N-m	N-m	N-m	N-m	N-m	N-m	N-m
0		1.1	2.3	3.4	4.5	5.6	6.8	7.9	9.0	10.2
100	11.3	12.4	13.6	14.7	15.8	16.9	18.1	19.2	20.3	21.5
200	22.6	23.7	24.9	26.0	27.1	28.2	29.4	30.5	31.6	32.8
300	33.9	35.0	36.2	37.3	38.4	39.5	40.7	41.8	42.9	44.1

FOOT POUNDS INTO NEWTON METERS

Ft-lb.	+0	+1	+2	+3	+4	+5	+6	+7	+8	+9
	N-m	N-m	N-m	N-m	N-m	N-m	N-m	N-m	N-m	N-m
20	27.1	28.5	29.8	31.2	32.5	33.9	35.3	36.6	38.0	39.3
30	40.7	42.0	43.4	44.7	46.1	47.5	48.8	50.2	51.5	52.9
40	54.2	55.6	56.9	58.3	59.7	61.0	62.4	63.7	65.1	66.4
50	67.8	69.1	70.5	71.9	73.2	74.6	75.9	77.3	78.6	80.0
60	81.3	82.7	84.1	85.4	86.8	88.1	89.5	90.8	92.2	93.6

5.3.6 SPEED

MILES PER HOUR INTO KTS

MPH	+0	+1	+2	+3	+4	+5	+6	+7	+8	+9
	KTS	KTS	KTS	KTS	KTS	KTS	KTS	KTS	KTS	KTS
0	0.0	0.9	1.7	2.6	3.5	4.3	5.2	6.1	7.0	7.8
10	8.7	9.6	10.4	11.3	12.2	13.0	13.9	14.8	15.6	16.5
20	17.4	18.2	19.1	20.0	20.9	21.7	22.6	23.5	24.3	25.2
30	26.1	26.9	27.8	28.7	29.5	30.4	31.3	32.2	33.0	33.9
40	34.8	35.6	36.5	37.4	38.2	39.1	40.0	40.8	41.7	42.6
50	43.4	44.3	45.2	46.1	46.9	47.8	48.7	49.5	50.4	51.3
60	52.1	53.0	53.9	54.7	55.6	56.5	57.4	58.2	59.1	60.0
70	60.8	61.7	62.6	63.4	64.3	65.2	66.0	66.9	67.8	68.6
80	69.5	70.4	71.3	72.1	73.0	73.9	74.7	75.6	76.5	77.3
90	78.2	79.1	79.9	80.8	81.7	82.6	83.4	84.3	85.2	86.0
100	86.9	87.8	88.6	89.5	90.4	91.2	92.1	93.0	93.8	94.7
110	95.6	96.5	97.3	98.2	99.1	100.0	100.8	101.7	102.5	103.4
120	104.3	105.1	106.0	106.9	107.8	108.6	109.5	110.4	111.2	112.1
130	113.0	113.9	114.8	115.6	116.5	117.3	118.2	119.1	120.0	120.8
140	121.7	122.6	123.5	124.3	125.2	126.0	126.9	127.8	128.7	129.5
150	130.3	131.2	132.1	132.9	133.8	134.7	135.6	136.5	137.4	138.2
160	139.0	139.9	140.8	141.6	142.5	143.4	144.3	145.2	146.1	146.9
170	147.7	148.6	149.5	150.3	151.2	152.1	152.9	153.8	154.7	155.5
180	156.4	157.3	158.2	159.0	159.9	160.8	161.6	162.5	163.4	164.2

5.3.7 DISTANCE

**STATUTE MILES, NAUTICAL MILES, AND
KILOMETERS**

(Statute Miles x 1.609 = Kilometers) (Kilometers x .622 = Statute Miles)

(Statute Miles x 8.69 = Nautical Miles) (Nautical Miles x 1.15 = Statute Miles)

(Nautical Miles x 1.852 = Kilometers) (Kilometers x .54 = Nautical Miles)

TABLE OF CONTENTS

SECTION 6

WEIGHT AND BALANCE

6	WEIGHT AND BALANCE	6-1
6.1	INTRODUCTION.....	6-1
6.2	PERTINENT INFORMATION FOR WEIGHT AND BALANCE.....	6-2
6.2.1	TERMINOLOGY.....	6-3
6.3	WEIGHING PROCEDURES	6-5
6.3.1	PREPARATION	6-5
6.3.2	LEVELING.....	6-6
6.3.3	WEIGHING.....	6-8
6.4	WEIGHT AND BALANCE DATA AND RECORD.....	6-9
6.5	WEIGHT AND BALANCE DETERMINATION FOR FLIGHT.....	6-12
6.6	SAMPLE WEIGHT AND BALANCE CALCULATION.....	6-14
6.7	COMPONENTS AND EQUIPMENT LIST.....	6-17

INTENTIONALLY LEFT BLANK

6 WEIGHT AND BALANCE

6.1 INTRODUCTION

This section provides two very important pieces of information. Paragraph 6.3 describes the methods for determining the empty weight of the aircraft and the position of the center of gravity relative to the datum. Paragraph 6.5 supplies the information necessary to calculate the takeoff weight and the position of the center of gravity for a given flight. An example is provided in paragraph 6.6.

Weight and balance limits are placed on aircraft for two reasons:

- The structure was designed to carry a certain weight.
- Weight and the position of the center of gravity affect performance, stability and control characteristics, particularly in stall and spin recovery.

The aircraft will only attain the performance and exhibit the handling characteristics used for certification if it is flown with the center of gravity within the approved range.

An overloaded aircraft will not take off, climb or cruise as well as a properly loaded one. Center of gravity is a determining factor in flight characteristics. If the C.G. is too far forward, the aircraft will require large stick forces for control and runs the risk of nosing over on the ground. If the C.G. is too far aft, the aircraft may pitch up during climb. Longitudinal and directional stability will be reduced. This can lead to inadvertent stalls and even spins. Spin recovery will become more difficult.

The CC18-180 will perform as intended when it is properly loaded. Before it was delivered, the aircraft was weighed and the C.G. location was computed. You will find this information in paragraph 6.4.

6.2 PERTINENT INFORMATION FOR WEIGHT AND BALANCE

Position of datum..... 60 inches ahead
of wing leading edge

Maximum gross weight.....2300 lbs.

Center of gravity limits at 2,300 lbs.

Forward79.1 in. aft of datum

Aft81.0 in. aft of datum

Center of gravity limits at 1,600 lbs. or less

Forward70.5 in. aft of datum

Aft81.0 in. aft of datum

Minimum operating weight 1,300 lbs.

Please note that the CC18-180 must not be operated under 1,300 lbs. It is very unlikely that a pilot will ever encounter this situation, given the empty weight of the standard aircraft with a pilot and adequate fuel.

Note that the aircraft can be equipped with different propellers and tires. These will affect weight and balance and performance. The standard aircraft is equipped with a Sensenich Propeller Manufacturing Company, Inc. model 76EM8, 76 diameter, 56 pitch propeller and Goodyear 8.50x6-6 tires.

6.2.1 TERMINOLOGY

Arm	The horizontal distance from the reference datum to the center of gravity (CG) of an item.
Basic Empty Weight	Standard empty weight plus optional equipment.
Center of gravity (C.G.)	The point at which an aircraft or an item of equipment would balance if suspended. Its distance from the reference datum is found by dividing the total moment by the total weight.
C.G Arm	The arm obtained by adding the airplane's individual moments and dividing the sum by the total weight.
C.G. Limits	The extreme center of gravity limits within which the aircraft must be operated at a given weight.
Datum	An imaginary vertical plane from which all horizontal distances are measured for balance purposes.

Moment	The product of the weight of an item multiplied by its arm.
Maximum Takeoff Weight	Maximum weight approved for the start of the takeoff run.
Standard Empty Weight	Weight of a standard airplane, including unusable fuel, full operating fluids and full oil.
Unusable fuel	The quantity of fuel at which the first evidence of malfunctioning occurs under the most adverse fuel feed condition occurring under each intended operation and flight maneuver involving that tank.
Useful load	Difference between takeoff weight and basic empty weight.

6.3 WEIGHING PROCEDURES

This procedure is to be followed for weighing the landplane. To weigh aircraft equipped with Wipaire 2100A and 2100S series floats, consult the maintenance manual, document TC10000AMM.

NOTE

For aircraft equipped with Wipaire 2100A, refer to Section 9.11.6 or Wipaire 2100S floats, see Section 9.13.6 Weight & Balance.

6.3.1 PREPARATION

Make sure that all of the equipment listed in the Aircraft Equipment List (Paragraph 6.4) is installed and in its proper location.

1. Remove any items not listed on the Aircraft Equipment List (such as rags, charts, tools, etc.).
2. Clean the aircraft to remove excess dirt and grease.
3. Remove the fuel from the aircraft. This may be accomplished by opening the fuel drains until all remaining fuel is drained. Add 3 gallons or 11.4 liters to each tank for unusable fuel required.
4. Check that the oil is full (8 quarts / 7.6 liters) on the dip stick.
5. Position the pilot's seat in the mid position. Retract the flaps, place all controls in neutral and ascertain that all doors are closed.
6. Place the aircraft in a hangar with the doors closed where the wind will not affect the readings of the scales.

6.3.2 LEVELING

Have a set of calibrated weighing scales available. The range should be 1,000 lbs. for each main and 250 lbs. for the tail.

1. Place the aircraft approximately in a flight level attitude by supporting the tail wheel on a bench.
2. Level the aircraft as follows:
 - Place a spirit level on the lower longeron between the landing gear tubes as shown in Figure 6-1. Lower or raise the tail until the aircraft is level. If necessary, this may be accomplished by letting air out of the tires.
 - Place the spirit level on the upper forward cross tube located in the cabin just behind the windshield, as shown in Figure 6-2.
3. Zero the scales or record the tare, as appropriate.
4. Place the aircraft on the calibrated weighing scales.



Figure 6-1 - Leveling the aircraft



Figure 6-2 - Leveling the aircraft

6.3.3 WEIGHING

Once the aircraft has been leveled, record the weight on the main wheels and the tail wheel.

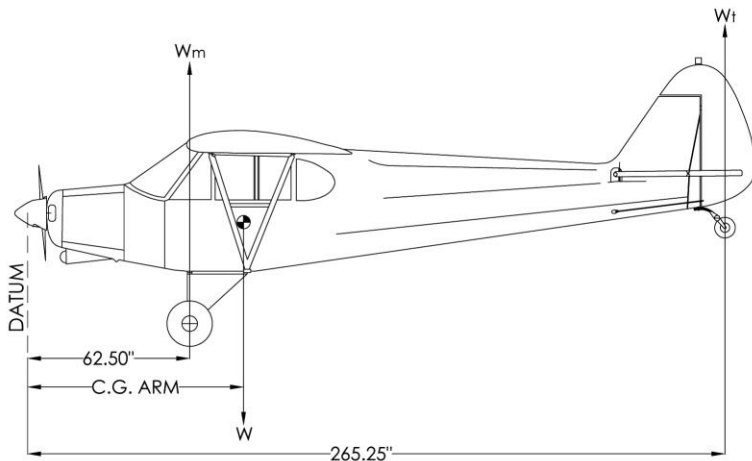


Figure 6-3 - Aircraft Geometry

$$C.G. Arm = \frac{(Wm \times 62.5) + (Wt \times 265.25)}{W}$$

Where:

- C.G. Arm = Distance from the datum to the center of gravity in inches
- W = Total weight of the aircraft
- Wm = Sum of the weight on both main wheels
- Wt = Weight on the tail wheel

6.4 WEIGHT AND BALANCE DATA AND RECORD

Table 6-1 shows the following information at the time when the aircraft was licensed at the factory:

- Basic Empty Weight
- Center of Gravity
- Useful Load

MODEL CC18-180

Aircraft Serial Number: _____
Registration Number: _____
Date: _____

Basic empty weight (lbs.)	Arm (in.)	Moment (in. lbs.)

Table 6-1 - Basic Empty Weight

Maximum takeoff weight - Basic empty weight
= Useful load

2,300 lbs. – _____

= _____ lbs.

This basic empty weight, C.G. and useful load are for the CC18-180 as it was licensed at the factory. Please refer to the appropriate aircraft records to determine the latest information, as the aircraft may have been altered.

INTENTIONALLY LEFT BLANK

MODEL:		SERIAL NUMBER		REGISTRATION NUMBER			PAGE NUMBER		
CC18-180							1 of 1		
Date	Item No.	Description of Article or Modification	Added (+) Removed (-)	Weight Change			Running Basic Empty Weight		
				Wt (lb.)	Arm (in.)	Moment	Wt (lb.)	Arm (in.)	Moment
		<u>Original Equipment List</u>							
	1								
	2								
	3								
	4								
	5								
	6								
	7								
	8								
	9								
	10								
	11								
	12								
	13								
	14								
	15								
	16								
	17								
	18								
	19								
	20								
		The above items are included in the empty weight.							

Table 6-2 Weight and Balance Record

INTENTIONALLY LEFT BLANK

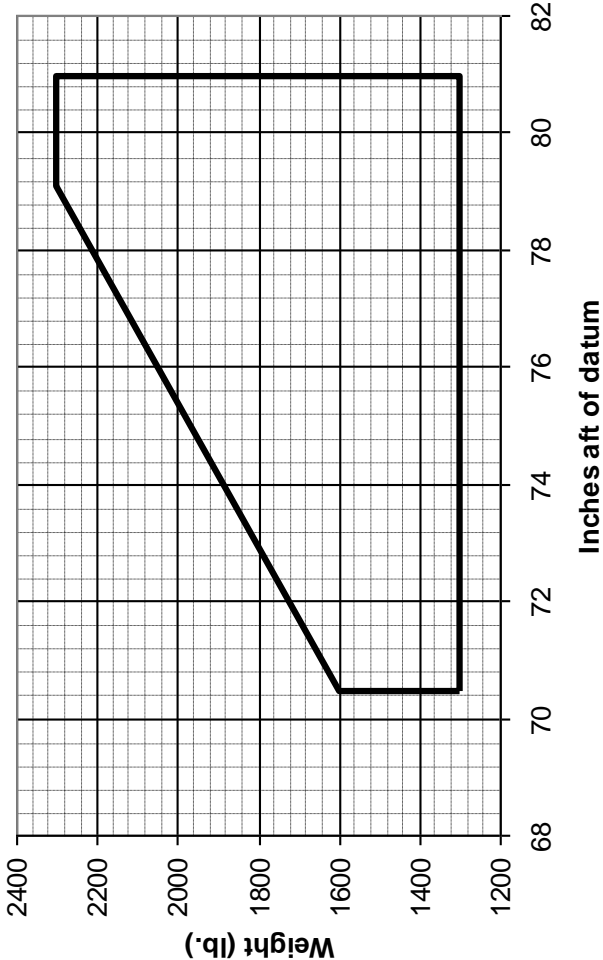
6.5 WEIGHT AND BALANCE DETERMINATION FOR FLIGHT

In order to calculate the weight and balance of the aircraft:

1. Insert the respective loads in Table 6-3.
2. Multiply each load by its respective arm and note the moment.
3. Add the loads to calculate the takeoff weight
4. Add the moments to compute the total moment.
5. Divide the moment by the takeoff weight. This is the final position of the center of gravity.
6. Plot the point on Figure 6-4. The point must be within the approved envelope for any operations.

	Weight (lbs.)	Arm (in.)	Moment (in. – lbs.)
Basic empty weight			
Pilot		71	
Passenger		97	
Fuel		84	
Cargo under seat (5 lbs. limit)		97	
Forward cargo compartment (behind passenger) (180 lbs. limit)		117	
Extended cargo compartment (behind forward compartment) (20 lbs. limit)		153	
Storage/accessory compartment (5 lbs. limit)		150	
Takeoff weight			

**Table 6-3 - Weight and Balance Loading Form
For Land-Based Aircraft**



**Figure 6-4 - Weight and Balance Envelope
for Land-Based Aircraft**

**6.6 SAMPLE WEIGHT AND BALANCE
CALCULATION**

This section will provide a sample weight and balance calculation using the methods given in paragraph 6.5.

	Weight (lbs.)	Arm (in.)	Moment (in.-lbs.)
Basic empty weight	1,228	70	85,960
Pilot	230	71	16,330
Passenger	200	97	19,400
Fuel	200	84	16,800
Cargo under seat (5 lbs. limit)	5	97	485
Forward cargo compartment (behind passenger) (180 lbs. limit)	50	117	5,850
Extended cargo compartment (behind forward compartment) (20 lbs. limit)	20	153	3,060
Storage/accessory compartment (5 lbs. limit)	0	150	0
Takeoff weight	1,933	76.5	147,885

Table 6-4 - Sample Weight and Balance

6.7 COMPONENTS AND EQUIPMENT LIST

This section provides a list of components and equipment that the operator is likely to change on the aircraft.

Description	Ref Drawing	Weight (lbs.)	Arm (in.)
8.50 x 6 x 6 Wheels/Tires	TC4000	23 each	62.50
26 x 10 x 6 Wheels/Tires	TC4000	30 each	62.50
Main Landing Gear without wheels/tires	TC4000	10 each	64.00
3200-Type Tail Wheel & Tire	TC4002	14	257.75
Sensenich Propeller Manufacturing Company, Inc. 76EM8, 76" diameter	TC5001	35.5	2.60
McCauley Propeller Systems 1A200/FA 82" diameter	TC10014	42.5	2.60
Sensenich Wood Propeller Company, Inc W80CM8 80" diameter	W80CM8	16	2.60

Table 6-5 Component and Equipment List

TABLE OF CONTENTS

SECTION 7

AIRCRAFT AND SYSTEMS

7 AIRCRAFT SYSTEM AND DESCRIPTION..... 3

7.1 INTRODUCTION 3

7.2 AIRFRAME 3

7.3 LANDING GEAR..... 4

7.4 FLIGHT CONTROLS 6

7.5 POWERPLANT..... 7

7.5.1 ENGINE..... 7

7.5.2 ENGINE MOUNT 7

7.5.3 PROPELLER 8

7.5.4 ENGINE COWLING 8

7.5.5 EXHAUST SYSTEM 8

7.5.6 IGNITION SYSTEM 8

7.5.7 AIR INDUCTION SYSTEM 8

7.5.8 OIL SYSTEM 10

7.5.9 FUEL SYSTEM..... 11

7.5.10 ELECTRICAL SYSTEM 13

7.5.11 LIGHTS..... 13

7.5.12 STALL WARNING 14

7.5.13 PITOT STATIC SYSTEM..... 15

7.6 COCKPIT..... 15

7.7 INSTRUMENT PANEL..... 17

7.7.1 ELECTRONICS INTERNATIONAL VA-1A
VOLT / AMMETER 21

7.7.2 ELECTRONICS INTERNATIONAL OPT-1
OIL PRESSURE/TEMPERATURE GAUGE 22

7.8 CABIN HEAT 23

7.9 BAGGAGE AND CARGO COMPARTMENT .. 23

7.10 ELT OPERATION AND LOCATION..... 25

7.11 COLD WEATHER OPERATION 28

Table of Figures

Figure 7-1 - Main Landing Gear (26" tires shown) 4
Figure 7-2 - Parking Brake 5
Figure 7-3 - Flap Lever 6
Figure 7-4 - Engine 7
Figure 7-5 - Oil Filler and Dip Stick 10
Figure 7-6 - Fuel Selector 12
Figure 7-7 - Fuel Gauges 12
Figure 7-8 - Grounding Point 12
Figure 7-9 - Interior Light Dimmer Switches 14
Figure 7-10 - Stall Warning Vane 14
Figure 7-11 - Pitot Tube and Static Ports 15
Figure 7-12 - Main Door 16
Figure 7-13 - Seat Adjustment 17
Figure 7-14 - Night Visor Installation 19
Figure 7-15 - Standard Instrument Panel 20
Figure 7-16 - VA-1A Volt/Ammeter 21
Figure 7-17 - Oil Temperature/Pressure Gauge 22
Figure 7-18 - Baggage Compartment 24
Figure 7-19 - Cross Tube 25
Figure 7-20 - ACK E-01 ELT Switch 26
Figure 7-21 - Artex ME406 ELT Switch 26
Figure 7-22 - Kannad 406AF ELT Switch 27
Figure 7-23 - ELT Transmitter Location 27

7 AIRCRAFT SYSTEM AND DESCRIPTION

7.1 INTRODUCTION

This section gives a description of the CC18-180 and the operation of its systems and standard equipment. For information and operation of optional equipment, please refer to Section 9.

7.2 AIRFRAME

The structure of the fuselage consists of a truss made of high strength steel tubing. The members are joined together using inert gas fusion welding. The steel structure is powder coated to protect it from corrosion.

The wing is made up of a framework of stamped aluminum ribs mounted onto extruded wing spars. Tubular drag and compression struts and high strength stainless steel drag wires make up the rest of the structure. The leading edges are covered with aluminum sheets. The wing tip is made from ash wood and is fairly resilient, enabling it to withstand standard operating forces.

The wings attach onto the fuselage with hinge fittings and are supported by two lift struts. The rigging of the wings is accomplished by adjusting the forks that join the lift struts to the fuselage.

The fin, rudder, stabilizers, and elevators are all constructed of tubular steel with steel channel ribs. Stainless steel tie rods and fittings brace the stabilizers to the fins and fuselage. The tail brace wires should not be used for lifting or handling the aircraft on the ground.

The fuselage, wings, empennage and landing gear are covered with a polyester fiber treated with Cub Crafters' proprietary covering process which provides an excellent, durable finish.

7.3 LANDING GEAR

The CC18-180 has a tail wheel configuration. The main landing gear legs are made from welded steel tubing (Figure 7-1). A combination of rubber shock rings and a hydraulic strut provide shock absorption. The main wheels carry 8.50 X 6-6 tires. 26 X 10.5-6 tires are offered as optional equipment.



Figure 7-1 - Main Landing Gear (26" tires shown)

Each main wheel is provided with a set of single disc brakes. The left and right systems are independent of each other. There are two valves that operate the parking brake located under the pilot's seat.

The units form an integral part with the copilot's heel brakes (Figure 7-2). To operate the parking brake, press both brake pedals and move both valves aft.



Figure 7-2 - Parking Brake

The tail wheel swivels through 360 degrees and is steerable via the rudder pedals. It is mounted to the fuselage with steel leaf springs. The standard tail wheel assembly is a Scott or ABI 3200.

7.4 FLIGHT CONTROLS

The CC18-180 has conventional controls, operated with a control stick and rudder pedals and actuated with cables. There is a trim control for the elevator located on the lower left side of the cockpit.

The flaps are slotted and a lever (Figure 7-3) on the left forward side of the cockpit operates the system. It has three positions, up (0°), first notch, (22°) and full flaps (50°).

The flap lever has a spring latch system that will hold the flap in the selected position. To extend the flaps, pull back on the lever. To retract them, press the button on the end of the lever while simultaneously applying a slight back pressure. Allow the flaps to retract by keeping the button pressed. They are spring loaded, and together with the air loads, they will tend to retract.



Figure 7-3 - Flap Lever

7.5 POWERPLANT

7.5.1 ENGINE

The CC18-180 is powered by either a Textron Lycoming O-360-C4P or O-360-C1G engine (Figure 7-4). This is an air-cooled, four cylinder powerplant that is capable of delivering up to 180 HP at 2700 RPM.



Figure 7-4 - Engine

A throttle controls power to the engine. Each crew member is provided with a throttle on the left side of the cockpit. The air to fuel mixture is adjusted manually with a control on the left side of the instrument panel. Pulling the mixture control all the way back operates a cut-off valve on the carburetor that stops the supply of fuel to the engine. The mixture control should always be used to stop the engine.

7.5.2 ENGINE MOUNT

The structure of the mount is made of 4130N steel and the engine is attached through rubber mounts that help reduce vibration.

7.5.3 PROPELLER

Several propellers are approved for use on the CC18-180. They are all fixed pitch. The standard aircraft comes with a Sensenich Propeller Manufacturing Company, Inc. 76EM8, 76 inch diameter, 56 inch pitch metal propeller.

7.5.4 ENGINE COWLING

The upper, forward and lower portions of the engine cowling are made of fiberglass, using fire resistant resins. The sides of the cowl are made of aluminum and are hinged so that they can be opened for inspection.

7.5.5 EXHAUST SYSTEM

The exhaust system is made of stainless steel. It is covered with a shroud that is used as a heat exchanger to draw hot air for the cabin and for the induction system.

7.5.6 IGNITION SYSTEM

Two independent magnetos supply the ignition for the engine. The pilot must ensure that both magnetos are operating correctly prior to takeoff. In an emergency, the engine will continue to run if one of the magnetos fails. Both magnetos have impulse-couplings so the engine should be started with both magnetos on. (Impulse couplings retard the spark during startup and prevent the propeller from kicking back).

7.5.7 AIR INDUCTION SYSTEM

The induction air for the engine enters through a filter on the lower side of the cowling. Alternatively, the pilot may use the carburetor heat control which operates a butterfly valve allowing heated, unfiltered air into the carburetor. The control is located on the upper left side of the instrument panel.

CAUTION

Ground operations with the carburetor heat control in the hot position must be limited because air bypasses the filter.

Should the air filter become obstructed, the carburetor air control provides an alternate means of supplying the engine with air for the induction system.

It is important that the pilot become knowledgeable about carburetor icing and the use of the carburetor heat. Cub Crafters recommends the following publication, available from the FAA website:

Advisory Circular 20.113 - Pilot Precautions and Procedures to be taken in Preventing Aircraft Reciprocating Engine Induction System and Fuel System Icing Problems.

WARNING
AS CARBURETOR ICE ACCUMULATES, IT PRODUCES AN EXCESSIVELY RICH AIR/FUEL MIXTURE. THE ENGINE MAY START TO LOSE POWER OR STOP COMPLETELY. AT THIS POINT THERE MAY NOT BE SUFFICIENT HOT AIR IN THE ENGINE COMPARTMENT TO MELT THE ACCUMULATION OF CARBURETOR ICE, EVEN WHEN THE CARBURETOR HEAT CONTROL IS IN THE FULL "HOT" POSITION.

In general, follow these practices:

When icing conditions exist, apply carburetor heat often in all phases of flight. The main symptom of icing in the induction system will be loss of power.

Never use partial carburetor heat unless the aircraft is equipped with a carburetor temperature gauge, ice light or similar instrumentation. Partial heat could make matters worse, unless you know exact carburetor temperatures. Remember, full heat or nothing.

Be especially vigilant at lower power settings. It is good practice to use carburetor heat on any descent where you have reduced power, especially for landing.

In conditions conducive to icing or if ice was noted during engine run-up, perform another carburetor heat check immediately before takeoff. DO NOT leave carburetor heat on for the actual takeoff.

7.5.8 OIL SYSTEM

The oil system is an integral part of the engine, except for the cooler that is mounted onto the baffles on the left side of the engine. The oil filler is on the right side of the engine, aft of the cylinders and may be reached by opening the right side cowling (Figure 7-5).



Figure 7-5 - Oil Filler and Dip Stick

7.5.9 FUEL SYSTEM

Fuel is stored in two tanks, one tank per wing. Each tank has a capacity of 25 gallons (94 liter); the usable amount is 22 gallons (83 liters). The tanks are made of welded metal and have sumps at the aft inboard end. These should be drained as part of each pre-flight inspection and whenever there is the possibility of water in the tanks.

The tanks feed into a selector valve located on the lower left side of the cockpit that has four positions (Figure 7-6):

- Both: The engine is fed by both fuel tanks
- Left: Fuel is supplied by the left tank
- Right: Fuel is supplied by the right tank
- Off: Fuel supply to the engine is cut off

Fuel will flow from one tank to the other when the selector is in either the Off or the Both position. When parking the aircraft on a slope, leave the selector on either the left or right position to prevent draining fuel unintentionally.

The engine may be operated on the Both, Left or Right positions. For takeoff and landing, the fuel selector must be in the Both position.

Fuel quantity is determined with two sight glass gauges located on either side of the cockpit at the wing root (Figure 7-7). The ventilation of the tanks is through vented fuel caps and tubes at the forward outboard edge. These tubes protrude under the wing close to the forward wing strut attachment and have check valves installed to allow air to be drawn in for venting and prevent fuel from draining out.

Prior to refueling the aircraft, connect the fueling equipment's grounding wire to either of the wing tie downs (Figure 7-8). This will ensure that there is no electrical potential difference between the aircraft and the fueling equipment and will minimize the risk of electrical sparks when the aircraft is being refueled.

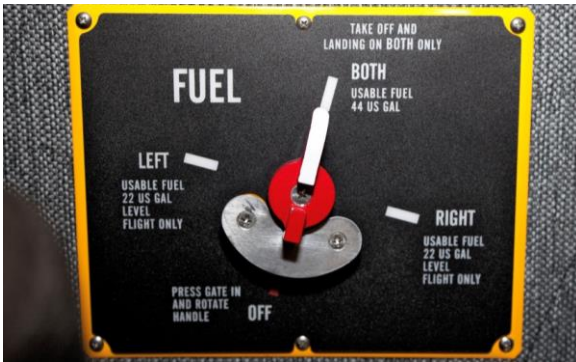


Figure 7-6 - Fuel Selector

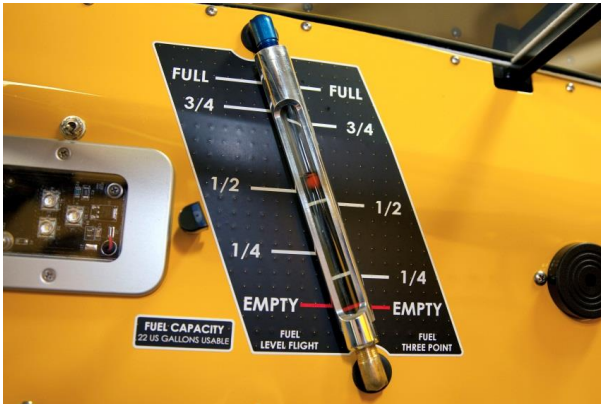


Figure 7-7 - Fuel Gauges

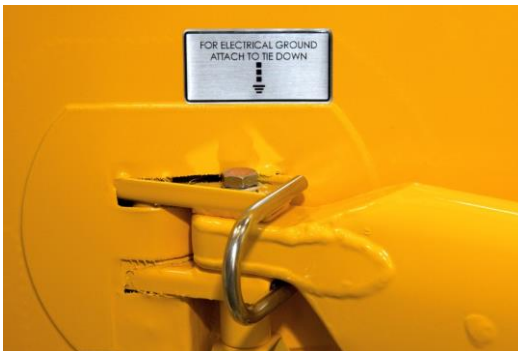


Figure 7-8 - Grounding Point

7.5.10 ELECTRICAL SYSTEM

The main sources of electrical energy are a 12 volt battery and a 40 amp alternator. The system has an over voltage relay and a voltage regulator. The battery is located in the accessory compartment behind the cabin and may be accessed through the door behind the right aft window.

7.5.11 LIGHTS

External lights consist of a strobe light on the tip of the rudder and navigation lights on the tips of the rudder and wings. The landing and taxi lights are located on the leading edge of the left wing.

The landing and taxi lights are operated by a single switch. Turning the lights on may cause the magnetic compass to have deviations greater than 10°.

Aircraft serial number 56 and on and aircraft modified in accordance with Service Letter 002 are equipped with interior lights for night VFR operations. The interior lights come on when the navigation lights are activated. The intensity of the interior lights is controlled by means of two dimmer switches located on the left side of the panel (Figure 7-9). Each dimmer switch consists of an inner and an outer controller.

The upper dimmer controls:

- Large knob: The LED digital readouts on the perimeter of the engine instruments and placards.
- Small knob: The backlight to the digital readouts of the engine instruments.

The lower dimmer controls:

- Large knob: Fuel sight gauges and map lights
- Small knob: Navigation instruments



Figure 7-9 - Interior Light Dimmer Switches

Aircraft serial numbers 0002 through 0055 that have not been modified in accordance with Service Letter 002 are not approved for night operations. Two dimmer switches control:

- Dimmer 1 (Upper): Instrument panel lighting.
- Dimmer 2 (Lower): Engine instrument LED lights on the outer ring. Green and yellow dimmed only. Red is always on full brightness.

7.5.12 STALL WARNING

The stall warning system is activated by a vane located on the leading edge of the right wing (Figure 7-10). As the aircraft approaches the stall, a horn will sound. The system is calibrated so that the horn will come on at least 6 miles per hour (5 knots) above the stall speed.



Figure 7-10 - Stall Warning Vane

7.5.13 PITOT STATIC SYSTEM

The pitot system senses dynamic pressure through a tube that is aligned with the flow of air, located under the left wing (Figure 7-11). The pitot tube is heated. Avoid prolonged operations on the ground as it can get very hot. Do not touch the pitot tube if the heat is on. Operation of the pitot heat may cause the magnetic compass to have deviations greater than 10°.

The static pressure orifices are located on both sides of the fuselage, just behind the engine (Figure 7-11). There are two orifices to counteract the effects of yaw.



Figure 7-11 - Pitot Tube and Static Ports

7.6 COCKPIT

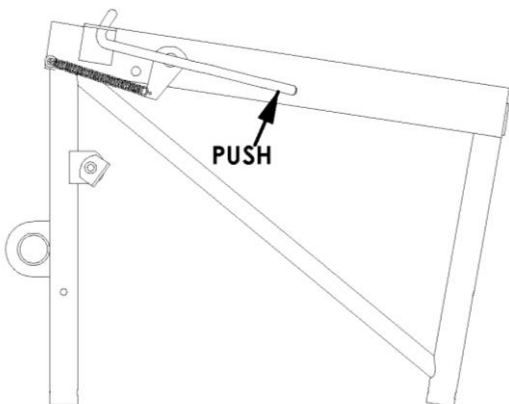
Entry to the cockpit is through a double door on the right side of the aircraft (Figure 7-12). The handle opens the lower half, which also releases the upper half; the upper portion must be raised until it engages the latch on the wing. To close the doors, they must be brought together while the handle is twisted and pushed to a close. The handle must only be released once the door is closed.

Make sure that the door pins have engaged on the forward and aft sides of the door.

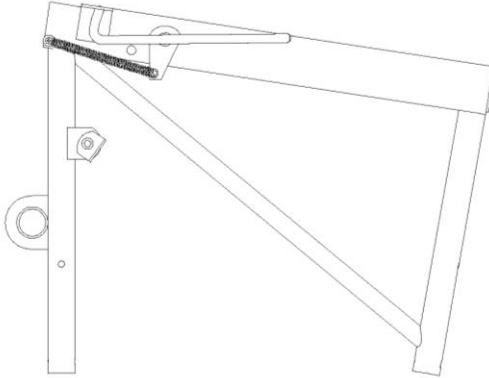


Figure 7-12 - Main Door

The CC18-180 seats two, in a tandem configuration. All flight controls are within reach of the forward occupant, and hence, the aircraft must be flown from this position. The aft occupant is provided with a stick, rudder pedals, throttle and brakes for flight instruction.



LOCKED POSITION



UNLOCKED POSITION

Figure 7-13 - Seat Adjustment

The forward seat is adjustable fore aft. To move the seat, operate the handle on the lower left side of the seat and slide to the desired position (Figure 7-13).

The seats are provided with special cushions and are designed for crashworthiness. The cushions must only be replaced with approved parts supplied by Cub Crafters; otherwise, the energy absorption mechanism will not operate as designed in a crash.

The sliding windows on the left may be opened for ventilation. In an emergency, they may be pushed out and used as an emergency exit.

7.7 INSTRUMENT PANEL

The instrument panel contains all flight, navigation and engine instruments that are required for day and night VFR operations. Figure 7-13 shows a typical panel. Note that the magnetic compass may have deviations greater than 10° when the landing/taxi lights or pitot heat are turned on.

For night operations on the aircraft so approved (0056 and on and aircraft modified in accordance with SL002), night visors must be installed. The visors are stowed in the upper compartment (Figure 7-18). There are four pieces:

- A left and a right side visor
- An instrument panel visor and
- A visor over the fuel selector

The visors must be installed as shown in Figure 7-14. They are attached with Velcro™. The pilot must ensure that they are secure in place and do not interfere with any of the controls prior to flight.

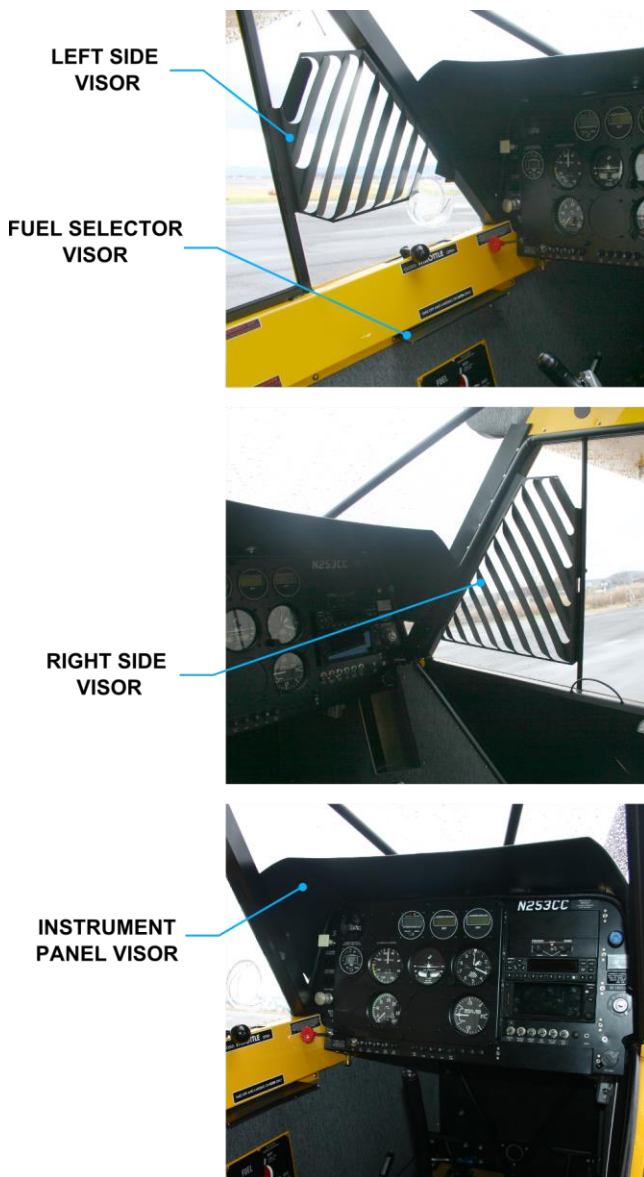
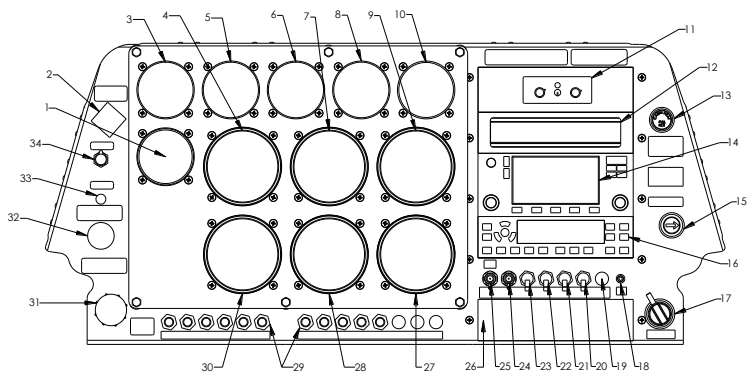


Figure 7-14 – Night Visor Installation



- | | | | |
|--------------------|----------------------|-------------------------|---------------------|
| 1 Volt/Ammeter | 10 Compass | 19 Blank Expansion | 28 Blank |
| 2 Carburetor Heat | 11 Intercom | 20 Pitot Heat | 29 Circuit Breakers |
| 3 Blank | 12 Map Pocket /Blank | 21 Anti-Collision Light | 30 Tach |
| 4 Airspeed | 13 Cabin Heat | 22 Nav Light | 31 Mixture Control |
| 5 Oil Temp/ Press | 14 GPS | 23 Landing Light | 32 Engine Primer |
| 6 EGT | 15 Starter | 24 Avionics Master | 33 Lower Dimmer |
| 7 Turn Coordinator | 16 XPDR | 25 Master Switch | 34 Upper Dimmer |
| 8 CHT | 17 Aux Power | 26 Blank | |
| 9 Altimeter | 18 Audio | 27 VSI | |

Figure 7-15 - Standard Instrument Panel

7.7.1 ELECTRONICS INTERNATIONAL VA-1A VOLT / AMMETER

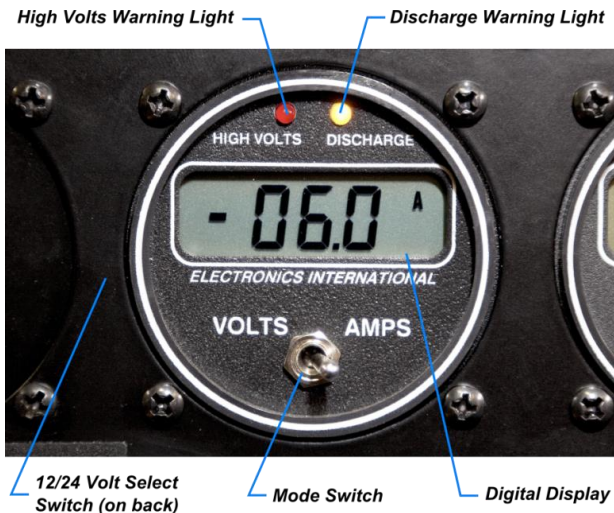


Figure 7-16 - VA-1A Volt/Ammeter

The CC18-180 is equipped with an Electronics International V1A-1A volt/ammeter.

The mode switch on the face of the instrument sets the display to read either voltage or amperage. If the bus voltage rises to 15.3 volts or higher, a bright red “HIGH VOLTS” warning light will alert the pilot of this condition. This feature will function regardless of the position of the mode switch. If the voltage drops below 12.6 volts, bright yellow ‘DISCHARGE’ warning light will illuminate. This feature will also function regardless of the position of the mode switch.

When the mode switch is in the “VOLTS” position, voltage is displayed in 0.1 volt increments and a “V” will show in the display. If the mode switch is in the “AMPS” position, the digital display will read amperage in 0.1 amps increments.

7.7.2 ELECTRONICS INTERNATIONAL OPT-1 OIL
PRESSURE/TEMPERATURE GAUGE



Figure 7-17 - Oil Temperature/Pressure Gauge

The CC18-180 is fitted with an instrument that combines oil pressure and oil temperature readings.

Oil pressure and oil temperature may read continuously on the LED lights around the rim of the gauge. A red light indicates an unsafe condition. A yellow light for oil pressure indicates caution. A yellow low oil temperature indication below 100°F is a cautionary indication provided to emphasize when the engine is operating outside the normal range. Takeoff must not be initiated when the oil temperature is below 100°F unless the engine accelerates smoothly when the throttle is opened. The normal ranges are displayed with green lights.

The digital display in the center of the gauge can read either pressure or temperature. To display pressure, the mode switch must be in the 'PSI' position and will read to within 1 psi. When the switch is in the 'TEMP' position, it will show temperature to within 1° F.

7.8 CABIN HEAT

Hot air for heating the cabin is supplied by a heat exchanger located around the engine exhaust muffler. Hot air enters the cabin through an opening on the engine firewall. To select the heater, the control on the upper right part of the instrument panel must be pulled aft.

7.9 BAGGAGE AND CARGO COMPARTMENT

There are three baggage compartments. The one under the passenger's seat has a capacity of 5 lb. It is reached by lifting the hinged, rear seat bottom.

The second compartment is behind the aft occupant and is divided into two areas. The forward cargo area has a capacity of 180 lb. and the aft area 20 lb. Cargo may either be loaded through the cockpit, over the right seat, or through the access door on the right side of the fuselage (Figure 7-18). There are 11 tie downs in this compartment. Each is rated for up to 50 lbs.

Above the second compartment is a storage area that also houses the aircraft's battery and the ELT. It may be used to stow up to 5 lbs. of soft items such as hats, coats and covers. The visors for night operations are stowed in this compartment.



Figure 7-18 - Baggage Compartment

The cross tube that supports the rear seat back may be swung up to make loading bulky items easier (Figure 7-19). This is done by removing the pin and swinging the cross tube upwards. The cross tube must be secured in place prior to flight.



Figure 7-19 - Cross Tube

7.10 ELT OPERATION AND LOCATION

The CC18-180 is supplied with either an ACK E-01 ELT transmitter per TSO C91a or an Artex Model ME406 ELT transmitter per TSO C126. or a Kannad Model 406AF Integra ELT per TSO C91a or TSO C126. The switch that activates the ELT in the cockpit is located on the upper left hand side of the cockpit, just forward of the left fuel gauge (Figure 7-20 and Figure 7-21).



Figure 7-20 - ACK E-01 ELT Switch



Figure 7-21 - Artex ME406 ELT Switch



Figure 7-22 - Kannad 406AF ELT Switch

The ELT is mounted to the aircraft structure just aft of the cabin (Figure 7-22). It may be reached and removed by first opening the storage compartment door located on the right side of the aircraft, just behind the right window.

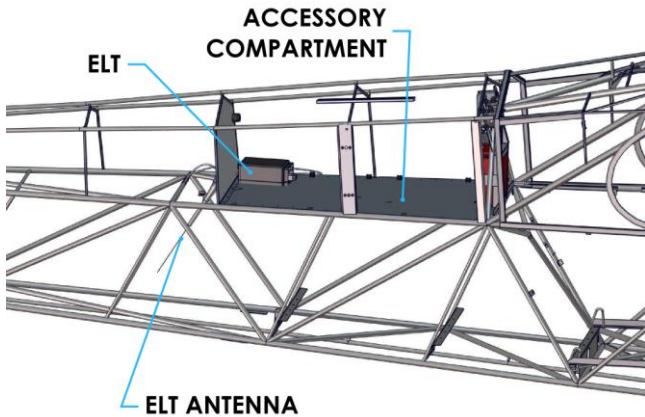


Figure 7-23 – ELT Transmitter Location

7.11 COLD WEATHER OPERATION

For cold weather operation, cowl inlet plates and an oil cooler plate may be installed to restrict airflow to the engine. This will increase engine oil temperatures when operating in colder climates. These plates must be removed when ambient temperatures exceed 40°F OAT. See SL0003 for Installation.

TABLE OF CONTENTS

SECTION 8

RESERVED

INTENTIONALLY LEFT BLANK

INTENTIONALLY LEFT BLANK

INTENTIONALLY LEFT BLANK

**TABLE OF CONTENTS
SECTION 9
SUPPLEMENTS**

9.1 PS ENGINEERING PM1000II INTERCOM..... 9.1.1
9.2 GARMIN GNC 420 COM/NAV 9.2.1
9.3 GARMIN GTX 327 TRANSPONDER..... 9.3.1
9.4 JPI EDM 800 ENGINE ANALYZER 9.4.1
9.5 GARMIN GNS 530 COM/NAV 9.5.1
9.6 GARMIN GTX 330 TRANSPONDER..... 9.6.1
9.7 GARMIN GMA 340 AUDIO PANEL 9.7.1
9.8 PS ENGINEERING PXE7300 IN FLIGHT
ENTERTAINMENT SYSTEM..... 9.8.1
9.9 OPTIONAL INSTRUMENT PANEL AND
VACUUM SYSTEM..... 9.9.1
9.10 GARMIN GNS 430 COM/NAV 9.10.1
9.11 WIPAIRE 2100A AMPHIBIAN FLOATS..... 9.11.1
9.12 SUPERIOR AIR PARTS O-360-A3A2
ENGINE 9.12.1
9.13 WIPAIRE 2100S SEAPLANE FLOATS..... 9.13.1
9.14 GARMIN GTN 635 GPS/COM 9.14.1
9.15 REAR CONTROL COVER..... 9.15.1
9.16 AIRCRAFT WITHOUT EXTENDED
CARGO COMPARTMENT 9.16.1

INTENTIONALLY LEFT BLANK

9.1 PS ENGINEERING PM1000II INTERCOM

9.1.1 GENERAL

This supplement must be attached to the Pilot's Operating Handbook and FAA Approved Airplane Flight Manual when the PS Engineering PM1000II intercom system is installed, per the Equipment List supplied with the aircraft and listed in Section 6 of this manual. The information contained herein supplements or supersedes the basic Pilot's Operating Handbook and FAA Approved Flight Manual only in those areas listed in this supplement. For limitations, procedures and performance information not contained in this supplement, consult section 2 of this Pilot's Operating Handbook and FAA Approved Airplane Flight Manual.

This supplement has been FAA approved as a permanent part of the handbook and must remain in the handbook at all times when the PS Engineering PM1000II intercom system is installed.

9.1.1.1 Descriptions



- | | |
|---------------------------|-----------------------------|
| 1. Pilot volume control | 4. Copilot squelch control |
| 2. Pilot squelch control | 5. Intercom mode switch |
| 3. Copilot volume control | 6. Power/transmit indicator |

9.1.2 LIMITATIONS

Installation of the PM1000II system does not alter the basic limitations provided in Section 2 of this Pilot's Operating Handbook and FAA Approved Airplane Flight Manual.

9.1.3 EMERGENCY PROCEDURES

There are no emergency procedures associated with the PM1000II system.

9.1.4 NORMAL PROCEDURES

Switch the unit on by turning the pilot's volume control (1) and turn to desired volume of the intercom.

Adjust the pilot's VOX sensitivity control (squelch) (2) until the desired sensitivity is reached for the pilot's microphone.

Adjust the copilot's volume control (3) for the volume of the intercom unit.

Adjust the copilot's VOX sensitivity control (squelch) (4) for desired sensitivity of the copilot's microphone.

9.1.5 PERFORMANCE

No change.

9.1.6 WEIGHT AND BALANCE

The PM1000II was installed at the factory and is included in the licensed weight and balance information in section 6 of the Pilot's Operating Handbook and FAA Approved Airplane Flight Manual.

9.1.7 DESCRIPTION AND OPERATION

Turn the PM1000II on by rotating pilot's volume control (1). The pilot's volume control does not control the aircraft's radio's volume.

9.1.7.1 Volume Control (1, 3)

Both pilot and copilot may transmit over the radio. The PM1000II allows only the person who presses their PTT (push to talk) to be heard over the aircraft radio. If both pilot and copilot press the PTT at the same time, the copilot will override. The pilot will regain priority by switching the unit off.

The pilot's volume control knob (1) adjusts the loudness of the intercom and music for the pilot's headset only. It has no effect on aircraft radio volume level. The copilot's volume control (3) adjusts the volume for the copilot.

9.1.7.2 Squelch Control (2, 4)

The PM1000II provides individual VOX circuits for the pilot and copilot. The ability to adjust the trip level of these VOX circuits (squelch control) allows the use of dissimilar headsets without the frustration of clipping the first syllables. The PM1000II has individual squelch circuits for the pilot and the copilot. With the engine running, set the squelch control by slowly rotating the knob(s) (2) and (4) clockwise until you no longer hear the background noise in the earphones.

When the microphone is positioned properly near the lips, normal speech levels should open the channel. When the crew member stops talking, there is a delay of about one second before the channel closes. This prevents squelch closure between words, and helps eliminate choppy intercom conversations.

9.1.7.3 Mode Selector

The center switch (5) is a three-position mode control that allows the pilot to tailor the intercom function to suit flight conditions. Regardless of configuration, the pilot will always hear the aircraft radio.

NOTE

If there is a power failure to the PM1000II, or if the power switch is turned off, the copilot will not hear the aircraft radio. Only the pilot is connected directly to the aircraft radio.

ISO (Up Position): The pilot is isolated from the intercom and is connected only to the aircraft radios. He will hear the aircraft radio reception (and side tone during radio transmissions). Copilot will hear themselves and music but not the aircraft radio traffic.

ALL (Middle position): All parties will hear the aircraft radio, transmit side tone from radio, intercom, and music. However, during any ICS or radio communications, the music volume automatically mutes. The music volume increases gradually back to the original level after communications have been completed. The bottom switch position is the same as the ALL mode.

9.1.7.4 Power/Transmit Indicator (6)

When the PM1000II is operating, the lamp in the center will glow green. When either pilot pushes a radio microphone key (push to talk, or PTT), the indicator will change to red signifying radio transmission. The aircraft radio side tone will be presented to the intercom, and heard by the same people as the aircraft radio receiver audio. Only the pilot pressing a PTT will be heard on the radio. Other microphones will be inhibited.

9.1.7.5 Fail-safe

If any abnormal conditions occur, such as a loss of radio communication, bypass the PM1000II by placing it in the “fail-safe” mode. When the PM1000II is turned off, either by the pilot volume control (1) or by pulling the “intercom” circuit breaker, the unit automatically enters the fail-safe mode. In this mode, the pilot microphone input is connected to the aircraft radio output, and the aircraft radio phones input is connected to the pilot headphone output, enabling pilot radio communication. The copilot's station is inoperative.

9.2 GARMIN GNC 420 COM/NAV

9.2.1 GENERAL

This supplement must be attached to the Pilot's Operating Handbook and FAA Approved Airplane Flight Manual when the Garmin GNC 420 is installed per the Equipment List supplied with the aircraft and listed in Section 6 of this manual. The information contained herein supplements or supersedes the basic Pilot's Operating Handbook and FAA approved Flight Manual only in those areas listed in this supplement. For limitations, procedures and performance information not contained in this supplement, consult Section 2 of this Pilot's Operating Handbook and FAA Approved Airplane Flight Manual.

This supplement has been FAA approved as a permanent part of the handbook and must remain in the handbook at all times when the Garmin GNC 420 is installed.

9.2.1.1 DESCRIPTION

The GNC 420 system is a fully integrated, panel mounted instrument which contains a VHF Communications Transceiver and a Global Positioning System (GPS) Navigation computer and a terrain awareness system (TERRAIN Option). The system consists of a GPS antenna, GPS Receiver, VHF COMM antenna and a VHF Communications Transceiver. The primary function of the VHF Communication portion of the equipment is to facilitate communication with Air Traffic Control. The primary function of the GPS portion of the system is to acquire signals from the GPS system satellites, recover orbital data, make range and Doppler measurements, and process this information in real-time to obtain the user's position, velocity, and time. The primary function of the TERRAIN portion of the system is to provide terrain situational awareness.

Provided the Garmin GNC 420's GPS receiver is receiving adequate usable signals, it has been demonstrated capable of, and has been shown to meet the accuracy specifications for:

- VFR/IFR enroute, terminal, and non-precision instrument approach (GPS, Loran-C, VOR, VOR-DME, TACAN, NDB, NDB-DME, RNAV) operation within the U.S. National Airspace System in accordance with AC 20-138.
- One of the approved sensors, for a single or dual GNC 420 installation, for North Atlantic Minimum Navigation Performance Specification (MNPS) Airspace in accordance with AC 91-49 and AC 120-33.
- The system meets RNP5 airspace (BRNAV) requirements of AC 90-96 and in accordance with AC 20-138 and JAA GAI-20 ACJ 20X4, provided it is receiving usable navigation information from the GPS receiver.
- The equipment as installed has been found to comply with the requirements for GPS primary means of navigation in oceanic and remote airspace, when used in conjunction with the 400 Series Trainer Program incorporating the FDE Prediction Program. This does not constitute an operational approval.

Navigation is accomplished using the WGS-84 (NAD-83) coordinate reference datum. Navigation data is based upon use of only the Global Positioning System (GPS) operated by the United States of America.

9.2.2 LIMITATIONS

The Garmin GNC 420 Pilot's Guide, P/N 190-00140-20, Rev. A, dated July 1999, or later appropriate revision, must be immediately available to the flight crew whenever navigation is predicated on the use of the system. In

In addition to the Pilot’s Guide, the appropriate Pilot’s Guide Addendum must also be immediately available to the flight crew if lightning detection, Traffic Advisory System (TAS), Traffic Information Service (TIS), Weather Datalink, or TERRAIN are interfaced to the system or if primary means oceanic/remote navigation is conducted.

The GNC 420 must utilize the following or later FAA approved software versions:

Function	Sub-System Version		
	Main	GPS	COM
Initial Approval	2.00	2.00	2.00
Traffic/Weather Interface	2.08	2.00	2.00
Primary Oceanic/Remote	3.00	3.00	2.00
TIS Interface	4.00	2.00	2.00
TERRAIN Option	5.01	3.01	6.00

The Main software version is displayed on the GNC 420 self test page immediately after turn-on for 5 seconds. The remaining system software versions can be verified on the AUX group sub-page 2, “SOFTWARE/DATABASE VER”.

If not previously defined, the following default settings must be made in the “SETUP 1” menu of the GNC 420 prior to operation (refer to Pilot’s Guide for procedure if necessary):

- **dis, spd:** nm, kt or mi, mph (sets navigation units to “nautical miles” and “knots” or “statute miles” and “mph”)
- **alt, vs:** ft fpm (sets altitude units to “feet” and “feet per minute”)
- **map datum:** WGS 84 (sets map datum to WGS-84, see note below)
- **posn:** deg-min (sets navigation grid units to decimal minutes)

NOTE

In some areas outside the United States, datums other than WGS-84 or NAD-83 may be used. If the GNC 420 is authorized for use by the appropriate Airworthiness authority, the required geodetic datum must be set in the GNC 420 prior to its use for navigation.

Navigation must not be predicated upon the use of TERRAIN.

CAUTION

The terrain display is intended to serve as a situational awareness tool only. It may not provide either the accuracy or fidelity, or both, on which to solely base decisions and plan maneuvers to avoid terrain or obstacles.

To avoid giving unwanted alerts, TERRAIN must be inhibited when landing at an airport that is not included in the airport database.

The TERRAIN databases have an area of coverage as detailed below:

- The Terrain Database has an area of coverage from North 75° Latitude to South 60° Latitude in all longitudes.
- The Airport Terrain Database has an area of coverage that includes the United States, Canada, Mexico, Latin America, and South America.
- The Obstacle Database has an area of coverage that includes the United States.

NOTE

Pilots are NOT authorized to deviate from their current ATC clearance to comply with terrain/obstacle warnings from a TERRAIN unit except as allowed by 14 CFR Part 91.3(b). TERRAIN warnings are advisory only and are not equivalent to warnings provided by a TAWS unit.

9.2.3 EMERGENCY PROCEDURES

In an in-flight emergency, depressing and holding the Comm transfer button for 2 (two) seconds will select the emergency frequency of 121.500 MHz into the "Active" frequency window.

CAUTION

This aircraft is not certified for IFR operations. The following procedures are included in this manual for advisory purposes only.

If Garmin GNC 420 navigation information is not available or invalid, utilize remaining operational navigation equipment as required. If the TERRAIN option is installed, TERRAIN will not be available. A white 'TER N/A' or red 'TER FAIL' annunciator will be displayed in the lower left corner of the GNC 420 display.

If "RAIM POSITION WARNING" message is displayed, the system will flag and no longer provide GPS based navigational guidance. The crew should revert to an alternate means of navigation other than the GNC 420's GPS Receiver. If the TERRAIN option is installed, TERRAIN will not be available. A white 'TER N/A' annunciator will be displayed in the lower left corner of the GNC 420 display.

If "RAIM IS NOT AVAILABLE" message is displayed in the enroute, terminal, or initial approach phase of flight, continue to navigate using the GPS equipment or revert to an alternate means of navigation other than the GNC 420's GPS receiver appropriate to the route and phase of flight. When continuing to use GPS navigation, position must be verified every 15 minutes using another IFR-approved navigation system.

If "RAIM IS NOT AVAILABLE" message is displayed while on the final approach segment, GPS based navigation will continue for up to 5 minutes with approach CDI sensitivity (0.3 nautical mile). After 5 minutes the system will flag and

no longer provide course guidance with approach sensitivity. Missed approach course guidance may still be available with 1 nautical mile CDI sensitivity by executing the missed approach.

If the white "TER N/A" status annunciator is displayed by the GNC 420, the system will no longer provide TERRAIN alerting or display relative terrain elevations. The crew must maintain compliance with procedures that ensure minimum terrain separation.

If the red "TER FAIL" status annunciator is displayed by the GNC 420, the system will no longer provide TERRAIN alerting or display relative terrain elevations. The crew must maintain compliance with procedures that ensure minimum terrain separation.

If a "TERRAIN has failed" or a "TERRAIN has failed" message is displayed by the GNC 420, the system will no longer provide TERRAIN alerting or display relative terrain elevations. The crew must maintain compliance with procedures that ensure minimum terrain separation.

9.2.4 NORMAL PROCEDURES

Normal operating procedures are described in the Garmin GNC 420 Pilot's Guide, P/N 190-00140-20, Rev. A, dated July 1999, or later appropriate revision.

9.2.5 PERFORMANCE

No change.

9.2.6 WEIGHT AND BALANCE

The Garmin GNC 420 was installed at the factory and is included in the licensed weight and balance information in section 6 of the Pilot's Operating Handbook and FAA Approved Airplane Flight Manual.

9.3 GARMIN GTX 327 TRANSPONDER

9.3.1 GENERAL

This supplement must be attached to the Pilot's Operating Handbook and FAA Approved Airplane Flight Manual when the Garmin GTX 327 Transponder is installed per the Equipment List supplied with the aircraft and listed in Section 6 of this manual. The information contained herein supplements or supersedes the basic Pilot's Operating Handbook and FAA Approved Flight Manual only in those areas listed in this supplement. For limitations, procedures and performance information not contained in this supplement, consult Section 2 of this Pilot's Operating Handbook and FAA Approved Airplane Flight Manual.

This supplement has been FAA approved as a permanent part of the handbook and must remain in the handbook at all times when the Garmin GTX 327 is installed.

9.3.1.1 DESCRIPTION

The GTX 327 is a solid-state Mode C digital transponder. It is TSO certified and its transmitter provides 200 watts nominal power output. The GTX 327 has a DSTN Liquid Crystal Display and a numeric keypad with a dedicated VFR code button. The GTX 327 also offers timing and display functions such as flight time and count-up and count-down timers, as well as current pressure altitude.

9.3.2 LIMITATIONS

Installation of the GTX 327 Transponder does not alter the basic limitations provided in Section 2 of this Pilot's Operating Handbook and FAA Approved Airplane Flight Manual.

9.3.3 EMERGENCY PROCEDURES

To transmit an emergency signal:

Mode selection key.....ALT
Code selection.....SELECT 7700

To transmit a signal representing loss of all communications:

Mode selection key.....ALT
Code selection.....SELECT 7600

9.3.4 NORMAL PROCEDURES

9.3.4.1 Before Takeoff

To transmit Mode C (Altitude Reporting) code in flight:

Mode selection key.....ALT
Code selector keys..... SELECT assigned code

To transmit Mode A (Aircraft Identification) code in flight:

Mode selection key.....ON
Code selector keys..... SELECT assigned code

NOTE

During normal operation with the ON mode selected, the reply interrogator “R” flashes, indicating transponder replies to interrogation.

NOTE

Mode A reply codes are transmitted in ALT also; however, mode C codes only are suppressed when the Function Selector ON is chosen.

9.3.5 PERFORMANCE

No change.

9.3.6 WEIGHT AND BALANCE


The Garmin GTX327 was installed at the factory and is included in the licensed weight and balance information in Section 6 of the Pilot's Operating Handbook and FAA Approved Airplane Flight Manual.

9.3.7 DESCRIPTION AND OPERATION

The GTX 327 transponder is powered on by pressing the **STBY**, **ALT** or **ON** keys, or by the remote avionics master switch. After the power has been turned on, a start-up page will be displayed while the unit performs a self-test.

9.3.7.1 Mode Selection Keys



- OFF** Powers off the GTX327.
- STBY** Powers on the transponder in standby mode. At power on, the last active identification code will be selected. When in standby mode, the transponder will not reply to any interrogations.
- ON** Powers on the transponder in Mode A. At power on, the last active identification code will be selected. In this mode, the transponder replies to interrogations, as indicated by the Reply Symbol on the display shown below.

- ALT** Powers on the transponder in Mode A and Mode C. At power on, the last active identification code will be selected. In ALT mode, the transponder replies to identification and altitude interrogations, as indicated by the Reply Symbol. Replies to altitude interrogations include the standard pressure altitude received from an external altitude source, which is not adjusted for barometric pressure. The ALT mode may be used in aircraft not equipped with the optional altitude encoder; however, the reply signal will not include altitude information.

9.3.7.2 GTX 327 Configuration Mode

The GTX 327's configuration, which is normally set at the time of installation, influences many of the unit's functions described in this manual. If you wish to change any of the GTX 327 configuration parameters, you may access the GTX 327 Configuration Mode. Use caution when changing configuration. When in doubt, contact an authorized Garmin Service Center. The Configuration Mode should not be used while the aircraft is airborne.

To use the GTX 327 Configuration Mode:

1. Press and hold the **FUNC** key while powering on the unit using the **STBY**, **ALT** or **ON** keys (or using the avionics master switch).
2. Press the **FUNC** key to sequence through the configuration pages.
3. Use the **CRSR** key to highlight the selectable fields on each page.
4. When a field is highlighted, enter numeric data using the **0-9** keys, and select items from a list using the **8** or **9** keys.
5. Press the **CRSR** key to confirm list selections.

9.3.7.3 Code Selection



Code selection is done with eight keys (**0-7**) that provide 4,096 active identification codes. Pushing one of these keys begins the code selection sequence. The new code will not be activated until the fourth digit is entered. Pressing the **CLR** key will move the cursor back to the previous digit.

Pressing the **CLR** key when the cursor is on the first digit of the code, or pressing the **CRSR** key during code entry will remove the cursor and cancel the data entry, restoring the previous code. The numbers **8** and **9** are not used for code entry, only for entering Count Down time, and in the Configuration Mode.

Important Codes:

- 1200** The VFR code for any altitude in the USA (Refer to ICAO standards elsewhere)
- 7000** The VFR code commonly used in Europe (Refer to ICAO standards)
- 7500** Hijack code (Aircraft subject to unlawful interference)
- 7600** Loss of communications
- 7700** Emergency
- 7777** Military interceptor operations (Never squawk this code)
- 0000** Military use (Not enterable)

Care should be taken not to select the code 7500 and all codes in the 7600-7777 range, which will trigger special indicators in automated facilities. Only the code 7500 will be decoded as the hijack code. An aircraft's transponder code (when available) is utilized to enhance the tracking capabilities of the ATC facility, Therefore, care should be taken when making routine code changes.

9.3.7.4 Keys for other GTX 327 Functions



IDENT- Pressing the IDENT key activates the Special Position Identification (SPI) Pulse for 18 seconds, identifying your transponder return on the air traffic controller's screen. The word "IDENT" will appear in the upper left corner of the display while the IDENT mode is active.



VFR- Sets the transponder code to the pre-programmed code selected in the Configuration Mode (this is set to 1200 at the factory). Pressing the **VFR** key again will restore the previous identification code.



FUNC- Changes the page shown on the right side of the display. Displayed data includes Pressure Altitude, Flight Time, Count Up timer and Count Down timer. In the configuration mode it steps through the configuration pages.



START/STOP- Starts and stops the count up and count down timers.



CRSR- Initiates entry of the starting time for the Count Down timer and cancels transponder code entry.



CLR -Resets the Count Up and Count Down timers and cancels the previous key press during code selection.



8-Reduces Contrast and Display Brightness when the respective pages are displayed. Also enters the number 8 into the Count Down timer.



9-Increases Contrast and Display Brightness when the respective pages are displayed. Also enters the number 9 into the Count Down timer.

9.3.7.5 Altitude Trend Indicator

When the “PRESSURE ALT” page is displayed, an arrow may be displayed to the right of the altitude, indicating that the altitude is increasing or decreasing. One of two sizes of arrows may be displayed depending on the rate of climb/descent. The sensitivity of these arrows is set using the GTX Configuration Mode.

9.3.7.6 Timer Operation

To operate the flight timer:

1. Press the **FUNC** key until “FLIGHT TIME” is displayed.
2. If desired, you may press **START/STOP** to pause or restart the timer.
3. Press **CLR** to reset the timer to zero

To operate the Count Up timer:

1. Press the **FUNC** key until “COUNT UP” is displayed.
2. If necessary, press **CLR** to reset the Count Up timer to zero.
3. Press **START/STOP** to count up.
4. Press **START/STOP** again to pause the timer.
5. Press **CLR** to reset the timer to zero.

To operate the Count Down timer:

1. Press the **FUNC** key until “COUNT DOWN” is displayed.
2. Press **CRSR** and use the **0-9** keys to set the initial time. All digits must be entered (use the 0 key to enter leading zeros).
3. Press **START/STOP** to count down.
4. Press **START/STOP** again to pause the timer.
5. When the Count Down timer expires, the words “COUNT DOWN” are replaced with “EXPIRED” and the time begins counting up and flashing.
6. Press **CLR** to reset the timer to the initial time value.

9.4 JPI EDM 800 ENGINE ANALYZER

9.4.1 GENERAL

This supplement must be attached to the Pilot's Operating Handbook and FAA Approved Airplane Flight Manual when the JPI EDM-800 Engine Analyzer is installed per the Equipment List supplied with the aircraft and listed in Section 6 of this manual. The information contained herein supplements or supersedes the basic Pilot's Operating Handbook and FAA Approved Flight Manual only in those areas listed in this supplement. For limitations, procedures and performance information not contained in this supplement, consult Section 2 of this Pilot's Operating Handbook and FAA Approved Airplane Flight Manual.

This supplement has been FAA approved as a permanent part of the handbook and must remain in the handbook at all times when the JPI EDM-800 Engine Analyzer is installed.

9.4.1.1 DESCRIPTION

The JPI EDM-800 Engine Analyzer is an engine data management system (EDM). It allows the pilot to monitor fuel flow and for each cylinder, engine exhaust gas temperature and cylinder head temperature. The system has various functions that give the pilot information for leaning mixture, diagnosing the condition of the engine as well as providing data on fuel flow and range.

9.4.2 LIMITATIONS

Installation of the JPI EDM-800 Engine Analyzer does not alter the basic limitations provided in Section 2 of this Pilot's Operating Handbook and FAA Approved Airplane Flight Manual.

9.4.3 EMERGENCY PROCEDURES

The EDM-800 should not be used as the primary means for determining the health of the engine. However, abnormal indications should not be disregarded and should be cross-referenced with other powerplant instruments. Any change in the behavior of the engine should be treated seriously and checked by a suitably qualified mechanic.

9.4.4 NORMAL PROCEDURES

The EDM-800 should only be used to complement the indications given by the primary powerplant instruments. It must not be relied on solely to determine the condition of the engine.

9.4.4.1 Engine Run Up

Suggested setup:

Run-up RPM

Normalize view
Manual Mode

Verify: uniform rise of about 50°F in all EGTs in single magneto operation and uniform rise of EGTs with application of the mixture control.

Be alert for: unusually low voltage (less than nominal battery voltage), abnormally high CHT, drop in EGT on one cylinder during single magneto operation – indicates fouled spark plug.

Include your EDM on your run-up checklist.

9.4.4.2 Take Off, Climb, and Full Throttle Operations

Suggested setup:

Percentage view
Automatic Mode

Verify: EGTs and CHTs consistent with past climbs. EGTs should be in the 1100°F to 1250°F range due to fuel cooling.

Be alert for: high EGT in one cylinder, 300°F above the others may indicate a leaking manifold gasket.

At high density altitudes an overly rich mixture can significantly reduce engine power.

9.4.4.3 Cruise

After the engine is warmed up, use LeanFind to lean the mixture.

Suggested setup:

Normalize view
Automatic Mode

Be alert for: Be alert for abnormal patterns of EGTs and CHT. (See Engine Diagnosis Charts on pages 9-54 thru 56). Make fine adjustments to RPM, then mixture to level the display columns.

9.4.4.4 Descent

Suggested setup:

Percentage view
Manual Mode

Be alert for: CLD: shock cooling alarm is set to -60°F. Average cool rates of -40°F/min to -60°F/min. are normal.

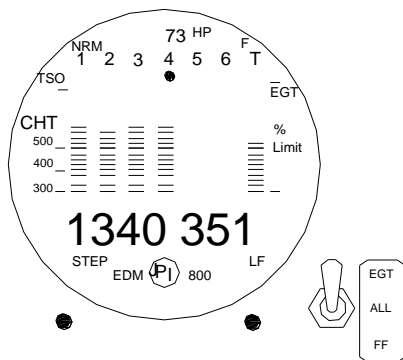
9.4.5 PERFORMANCE

No change.

9.4.6 WEIGHT AND BALANCE

The EDM-800 was installed at the factory and is included in the licensed weight and balance information in Section 6 of the Pilot's Operating Handbook and FAA Approved Airplane Flight Manual.

9.4.7 DESCRIPTION AND OPERATIONS



INDICATION	PARAMETER
1340 376	EGT right, CHT left
-30 CLD	Rate of shock cooling
14.2 BAT	Avionics bus voltage
81 OAT	Outside air option
300 CDT	Compressor discharge option
125 IAT	Induction air option
132 C-I	Compressor minus induction difference
-22 CRB	Carburetor option
80 DIF	Difference between hottest and coldest EGT

INDICATION	PARAMETER
2450 RPM	RPM
23.1	MAP
37.2 REM	Fuel remaining
25.9 REQ	Fuel required to wpt (GPS connected)
11.3 RES	Fuel reserve at wpt (GPS connected)
13.0 MPG	Miles per gallon (GPS connected)
02.45 H.M	Fuel time to empty
13.5 GPH	Gallons per hour
38 USD	Fuel used since fill or reset

Figure 9-4-1 Description of Display

* Numbers shown are for the purposes of an example only and should not be construed to apply to any aircraft

The EDM-800 includes fuel flow, RPM and manifold pressure sensors to display percent-horsepower. Horsepower or RPM will always be shown at the top of the instrument. The EDM monitors engine temperatures and voltages, assists in adjusting the fuel/air mixture and helps diagnose engine malfunctions.

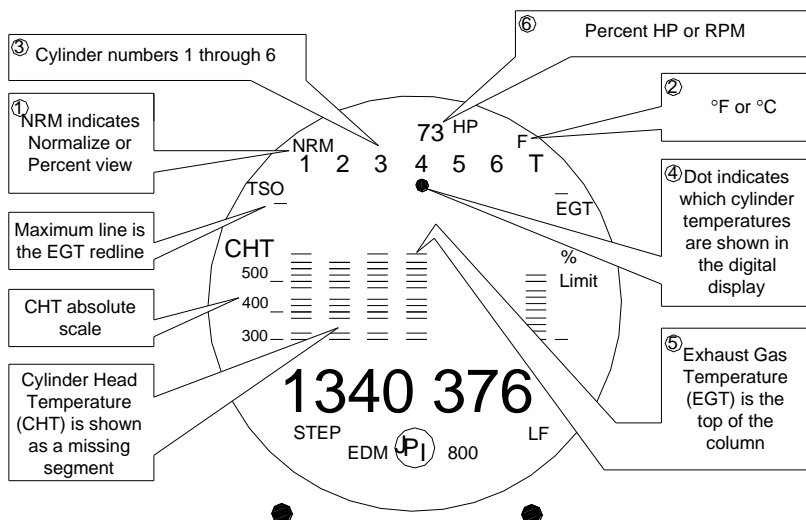


Figure 9-4-2 EDM-800 Display

9.4.7.1 Display

① *Normalize and Percentage View Indicators*

- **Percentage view:** when NRM is not lighted, the columns indicate percent of maximum EGT. Each column is composed of a stack of segments. A maximum height column depicts 100 % of the maximum limit and a one segment-high column depicts 50 % of the maximum limit. For example, if the maximum for that parameter were 1650°F, a maximum height column would represent 1650°F and a one segment-high column will equal half that value, or 825°F. The *Percentage view* permits comparison of EGTs *across all* cylinders. Hotter cylinders display higher columns than cooler cylinders.
- **Normalize view:** when the letters NRM are lighted on the left side, the EGT columns are displayed normalized. When you change to the Normalize

view, all columns are initially set to the same half-height level for trend analysis. Any changes are shown as an increase or decrease in column height. A one segment change in column height represents a 10°F change. The Normalize view permits rapid visualization of EGT trends, rather than as a percentage of maximum EGT. You can use normalize in level cruise and run-up.

To toggle between Percentage and the Normalize views, hold the LF button for five seconds until the display changes. The bar display becomes half height and the display changes to the Normalize view. Selecting the Normalize view does not affect the digital display nor alter the parameter sequence. The CHT display—described later—is not affected by the Normalize or Percentage view.

You may select the Normalize view in either the Manual or Automatic mode (see 9.4.7.3). Normalize view is most helpful for engine trend monitoring of each cylinder's operation. For example using the Normalize view during engine run-up, a fouled spark plug will appear as a higher column.

A common misapplication is to be in the Normalize view and then change your power setting, causing all columns to go off scale, high or low. Set to the Percentage view before adding or reducing power. Always set Percentage View when beginning your descent.

② *Temperature Units (°F or °C)*

- °F temperatures in the digital display are in Fahrenheit degrees.
- °C temperatures in the digital display are in Celsius degrees.

③④ *Cylinder Numbers and Dot Index*

A row of numbers 1 through 6 and the letter T are the column labels for the bar display. The 1 through 4 are the cylinder numbers (numbers 5 and 6 are disabled as the engine has four cylinders). A round dot under the numbers 1 through 4 indicates that particular column is shown numerically in the EGT and CHT digital display.

⑤ *Bar Graph EGT and CHT*

Each column in the bar graph is composed of a stack of segments. The total height of each column represents the **EGT** and the missing segment in the column represents the **CHT**.

- In the Percentage view, the EGT resolution depends on the programmed maximum limits.
- CHT is displayed by a missing segment and should be interpreted as follows: a missing segment corresponds to the CHT in 25 F° increments, starting at 300°F at the bottom. In the example shown in Figure 9-4-3, the CHT is 350°F. If the EGT bar is lower than the missing CHT segment, then the CHT will be indicated by a single isolated lighted segment.

The CHT display is the not affected by mode or view.

© *Percent HP or RPM*

Displays percent of rated HP or RPM depending on pilot programming.

Beneath the bar graph is the 9-segment alphanumeric display.

9.4.7.2 Buttons



Figure 9-4-3 EDM-800 Buttons

NOTE

The term tap is used to denote pressing a button momentarily. The term hold is used to denote pressing and holding a button for five seconds or longer.

STEP Button

The STEP button is located on the lower left side near the instrument face.

In the Automatic mode (see section 9.4.7.3), *tapping* the STEP button will stop and change to the Manual mode. Then each *tap* of the STEP button will display the next parameter in the sequence.

In the LeanFind mode (see section 9.4.7.9), *tapping* the STEP button will terminate the LeanFind mode and change to the Automatic mode.

LF Button

Located on the lower right side near the instrument face.

- In Automatic or Manual modes (see section 9.4.7.3), tapping the LF button will change to the LeanFind mode.
- In Automatic or Manual modes holding the LF button for three seconds will toggle between Percentage and Normalize views.
- In the LF mode (see section 9.4.7.9), holding the LF button after peak EGT is found will display peak EGT.
- In the LF mode tapping both the STEP and LF buttons simultaneously will mark a data record in long term memory and display will flash SNAP.

STEP and LF Buttons

- Holding both the STEP and LF buttons simultaneously for five seconds changes to the pilot programming procedure.
- Holding both the STEP and LF buttons simultaneously for five seconds after entering LeanFind mode (see section 9.4.7.9), but before beginning to lean will toggle between leaning “rich of peak” and “lean of peak.”
- Tapping both the STEP and LF buttons simultaneously in Manual mode (see section 9.4.7.3), toggles to include or exclude the displayed parameter from the Automatic mode. It has no affect on the displayed parameters in the Manual mode.

9.4.7.3 Modes

The EDM has three different operating modes: *Automatic*, *Manual*, and two *LeanFind* sub modes. When you first turn on the power the EDM starts in the Manual

mode, but will enter the Automatic mode after one minute. The Automatic mode provides you with engine monitoring information for the majority of flight conditions. To adjust the mixture, use the LeanFind mode. To display specific parameters, use the Manual mode. In both the Automatic and Manual modes the display shows a bar graph of EGT and CHT for each cylinder.

9.4.7.3.1 Automatic Mode

Tap the LF button and then tap the STEP button. In the Automatic mode the EDM displays the parameter sequence at a user-selected rate

Some individual parameters can be excluded from the Automatic mode: tap STEP to enter the Manual mode. Tap STEP to index to the parameter you want to exclude. Then tap both the STEP and LF buttons simultaneously. Excluded parameters display a decimal point before the parameter name.

Tapping the STEP and LF buttons simultaneously will toggle back and forth between include and exclude.

- Every time you turn on the EDM, all parameters are reset to be included.
- All installed parameters are always displayed in the Manual mode. Exclusion only applies to the Automatic mode.
- All parameters are checked for alarm conditions every second regardless of their included or excluded status.
- You cannot exclude EGT, CHT

9.4.7.3.2 Manual Mode

Tap the STEP button. Use the Manual mode when you want to monitor one specific parameter such as shock cooling during descent, or a particular cylinder temperature during climbs. To change to the Manual mode, tap the STEP button once. Subsequent taps will index the digital display through the parameter. To exit the Manual mode and return to the Automatic mode, either tap the LF button and then tap the STEP button or wait 5 minutes. You may disable the Automatic mode by setting "0" for scan rate.

9.4.7.3.3 LeanFind Mode

Refer to section 9.4.7.9.

9.4.7.4 Display Dimming

The entire display panel features automatic dimming. Allow ten seconds for the display to adjust to ambient lighting conditions.

9.4.7.5 Fuel Flow Display Select Switch

The select switch is a three-position toggle switch mounted on your instrument panel near the display of the EDM. It affects only the display scan (Figure 9-4-1).

- In the EGT position only the installed temperature (and battery voltage) parameters are displayed.
- In the ALL position, the EDM both installed temperature and fuel flow parameters are displayed.
- In the FF position only fuel flow parameters are displayed.
- Any alarm warning will appear regardless of the select switch setting. These parameters are displayed in the digital display in either the Automatic or Manual modes. The select switch does not effect the bar display.

9.4.7.6 EGT and CHT

When the dot index is beneath a cylinder number (1 through 4), the digital display shows the EGT on the left (four digits) and the CHT on the right (three digits).

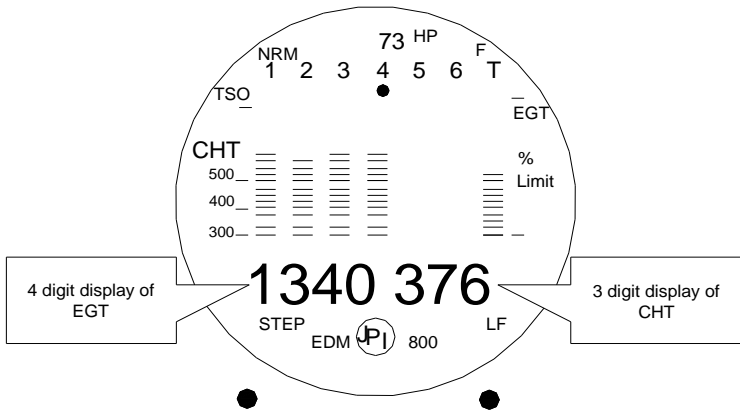


Figure 9-4-4 EGT and CHT

9.4.7.7 EGT

EGT is shown on the first four bar graph columns. These are labeled 1 through 4 above the columns. The lower limit of the graph range represents half of the allowable range and the top of the range represents the maximum temperature. When there is a dot under one of the cylinder numbers above the column, the appropriate numerical value of the EGT is shown on the left side of the digital display cylinder. In the example above, the EGT for cylinder 4 is 1340°F.

9.4.7.8 CHT

The CHT is represented by a missing segment in the bar graph column. The scale is shown on the left side of the bezel. The numerical value of the CHT is shown on the right side of the digital display for each cylinder when

there is a dot under one of the cylinder numbers above the column. In the example above, the CHT in cylinder 4 is 376°F.

9.4.7.9 LeanFind

JPI's EDM-800 provides two methods of leaning: rich of peak (LEAN R) or lean of peak (LEAN L) (in other words, leaning past peak EGT). Lycoming does not recommend operations lean of peak.

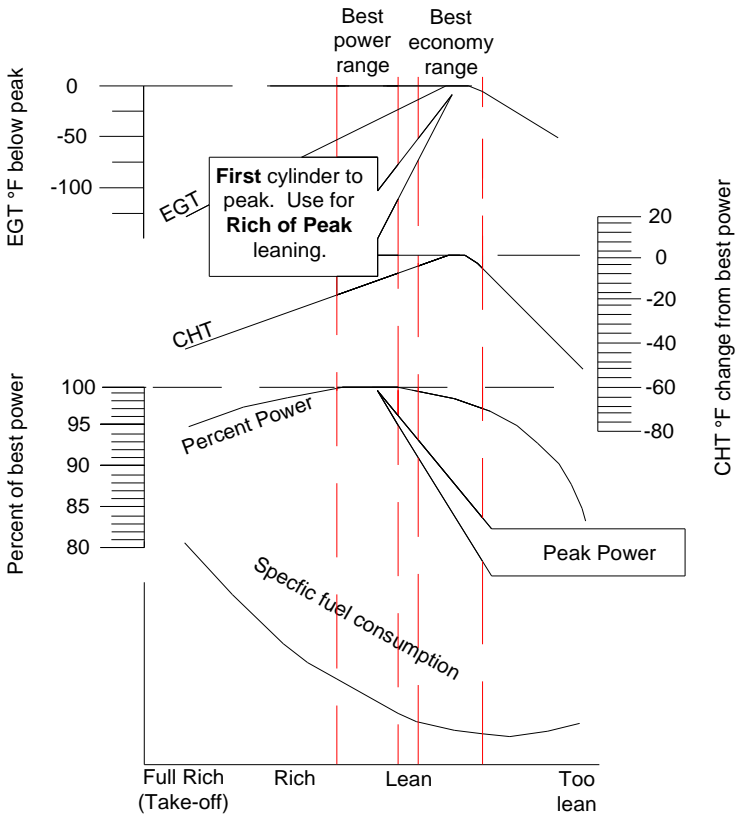


Figure 9-4-5 Leaning Chart

	Procedure	Example	Comments
1	Establish cruise at approx. 65 to 75% power.		
2	Pre-lean the mixture to 50°F estimated rich of peak EGT on any cylinder ____°	1490 370	*For your <i>first flight</i> with the EDM, use the method shown below.
3	Wait one minute		Let engine stabilize.
4	Tap the LF button	LEAN R	Start LeanFine. (Optionally to change to "lean of peak" method, hold both STEP and LF simultaneously.)
5	Lean the mixture - approx. 10°/second <i>without pausing</i> - while observing the display. When there is a 15°F rise in EGT, LeanFind mode becomes active.	1520 13.8	Flashing cylinder DOT indicated hottest cylinder and that LeanFind mode is active.
6	Stop leaning when a column begins flashing. You will see LEANEST for two seconds, followed by:	1545 12.4	Flashing cylinder dot & column indicates leanest cylinder. (SET means Set the mixture.) Due to thermal inertia this will usually be about -15°F lean of peak.
7	If you hold LF, peak EGT will be displayed while the LF button is held down.	1560 PK	Captured peak EGT value is displayed.
8	Slowly enrich the mixture. The temperature will increase, returning to peak. Stop enriching at the desired EGT. Best economy 1560 SET Best power 1460 SET	1560 SET 1560 SET 1460 SET	<ul style="list-style-type: none"> • Peak EGT for best economy • 100° rich of peak for best power

Table 9-4-1 Procedure for Leaning

NOTE

All the numbers given are examples and should not be construed to apply to any particular aircraft. If you are unfamiliar with the aircraft and do not have an estimate of the value of peak EGT, establish the aircraft in a cruise configuration while in cruise at 65% power. Choose any cylinder and lean that cylinder to peak EGT in the Manual mode or until the engine runs rough, whichever occurs first. Note the peak, subtract 50° and record the resulting number for future reference.

Lycoming has established specific restrictions on leaning that must be followed, such as percentage of power, and climb leaning. Lycoming recommends operation at peak EGT for power settings of 75% or lower. This guide is not meant to supersede any specific recommendations of the engine manufacturer or airframe manufacturer. It is your responsibility to know your aircraft's limitations. Pre-lean the mixture to about 50° below peak. After pre-lean, wait for one minute for the temperatures to stabilize. Next, begin the leaning process by tapping the LF button. This tells the EDM to begin looking for a 15° rise in EGT for any cylinder. Begin leaning the mixture without pausing. When a 15° rise occurs, eliminating false peaks, the LeanFind mode becomes activated shown when the cylinder dot above the column of the hottest cylinder begins flashing. **The LeanFind mode is not active until a cylinder dot is blinking.**

With the Fuel Flow Option (installed in the EDM-800), instead of seeing LF in the display, you will see numerical fuel flow rate during the leaning process on the right side of the digital display. This allows you to observe the EGT rise and at the same time watch the fuel flow rate decrease. To show the progress of the leaning process, the EDM selects the hottest cylinder for reference in the digital display. In the example in Figure 9-4-6, 1360 is the current temperature of the hottest cylinder and the fuel flow is 13.8.

When LF is activated:

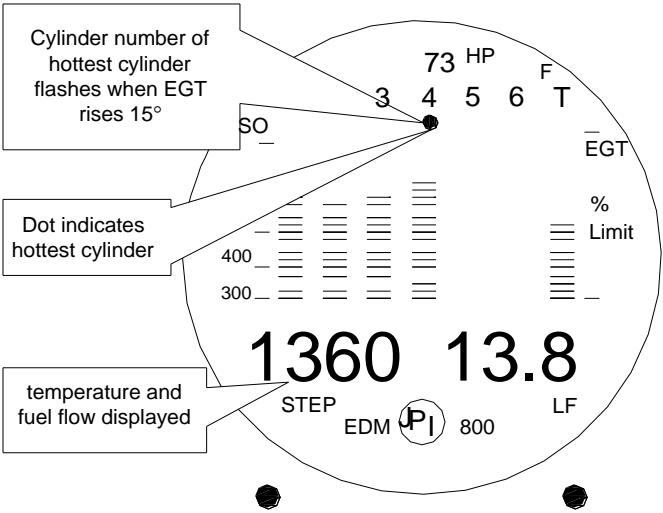


Figure 9-4-6 Leaning Example

Continue leaning slowly without pausing. Lean slowly and smoothly. Eventually, one cylinder will reach peak before any of the other cylinders. The EDM will determine this automatically. Notice that this cylinder does not necessarily have the hottest EGT.

The EDM will indicate success in finding a peak by displaying the words LEANEST for two seconds, followed by flashing the column and displaying the value of the EGT of the cylinder that peaked first. The word SET will also be displayed. (With the Fuel Flow Option the current fuel flow rate will be displayed on the right side of the digital display instead of the word SET.) The flashing cylinder will be locked—or set—into the digital display during the remainder of the LeanFind procedure to allow you to set the final mixture. The peak EGT value is remembered by the EDM and will be displayed as long as you hold the LF button.

Enrichen the mixture to operate at peak or continue enriching until the EGT reaches a temperature consistent with the procedures defined in the engine manual. If you lean too much, the EGT will drop and the engine will be operating lean of peak.

9.4.7.10 True and Delta Rich of Peak

TRUE EGT: After peak EGT is found using the “rich of peak” method, the left display will show the true EGT of the first cylinder to peak. As you enrich the mixture, this value will climb to peak. You can stop leaning when you have reached the desired temperature, either peak or continue to some value rich of peak.

For example if the value were 1,340, enriching the mixture and produce a peak of 1,350, identified when the value stops increasing, and declines as you continue to enrich.

DELTA EGT: If you want to see the difference (delta) between EGT and peak instead of the true EGT, tap LF once after finding peak. The value will be displayed as a negative number, showing the temperature difference below peak (delta). As you enrich the mixture, this value will climb back to zero. You can stop leaning when you have reached the desired temperature, either 0 for peak or continue to some value rich of peak such as -50. For example, if the value were -10 enriching the mixture may produce a peak of 0 and become negative as you continue to enrich. You can toggle between True and Delta displays by tapping LF. The EDM will remember the last selection chosen for the remainder of the flight.

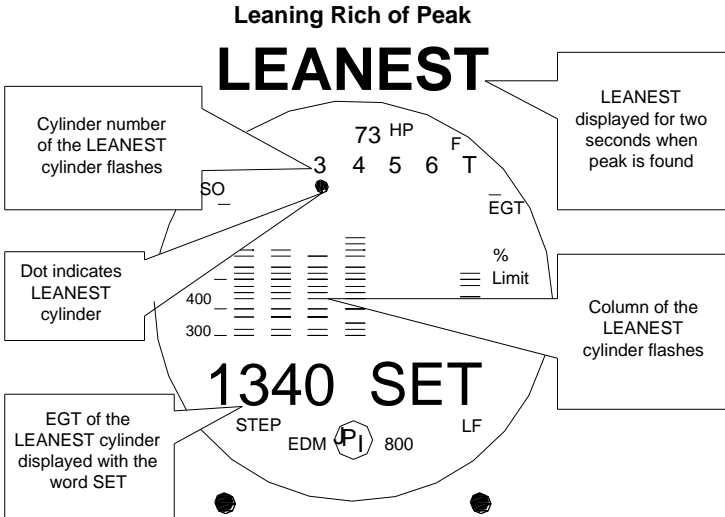


Figure 9-4-7 Leaning Rich of Peak

9.4.7.11 Typical Normal Parameters

The following chart lists typical normal parameter values that you will observe on a carbureted engine.

Parameter	Normal range	Comments
EGTs in Cruise	1350°F	EGT should drop 200°F when throttle is applied
EGT span (DIF)	120 to 150°F	Between Cylinders
CHTs	350°F (OAT 60°F)	
CHT span	50 to 70°F	Between Cylinders
Shock cooling*	-40°F/minute	

Table 9-4-2 Typical Normal Parameters

*Maintain a cooling rate of less than -60°F/minute. You will find that the cylinder with the greatest shock cooling will shift from front cylinders (during climb out) to the rear cylinders (during descent).

For more details on diagnosing the health of the engine, please refer to the EDM-800 Pilot’s Guide, published by J.P. Instruments Inc.

9.4.8 Fuel Flow

9.4.8.1 Start Up Fuel

After initial self-test, you will be asked to inform the EDM of start up fuel. The EDM will display FUEL for one second, and then flash “FILL? N” until any button is pressed. During flight you may also inform the EDM of startup fuel using the pilot program mode display if you forgot to do so at start up.

9.4.8.2 Accumulate Total—Trip Total

You may either display total fuel used since the last time you informed the EDM that the aircraft was refueled, or for an extended trip with multiple fuel stops. This selection affects only the USD parameter.

9.4.8.3 Resetting “USED”

Every time you inform the EDM that the aircraft is refueled, the amount of fuel used is set to zero, unless the instrument is programmed to accumulate. The display of fuel used pertains only to the fuel used since the last time you informed the EDM that the aircraft was refueled. To reset to zero the amount of fuel used at any point in time, manually step to display USD and hold both buttons for five seconds until the display shows .0 USD.

9.4.8.4 Fuel Management

CAUTION

For fuel calculations to be accurate, it is imperative that you inform the EDM of the correct amount of fuel aboard the aircraft. Do not rely on fuel flow instruments to determine fuel levels in tanks. Refer to original fuel instrumentation for primary information.

The EDM Fuel Flow uses a small, turbine transducer that measures the fuel flowing into the engine. Higher fuel flow causes the transducer turbine to rotate faster which generates a faster pulse rate. Because the transducer turbine generates thousands of pulses per gallon of fuel, it can measure with high resolution the amount of fuel that flows into the engine.

Prior to engine start you inform the EDM Fuel Flow of the known quantity of fuel aboard, and it will keep track of all fuel delivered to the engine. **During flight you may also**

inform the EDM of startup fuel using the pilot program mode display if you forgot to do so at start up.

9.4.9 Alarms

The EDM has programmable alarms. When a parameter falls outside of its normal limits, the digital display will flash with the value and abbreviation of the alarming item. If the condition triggering the alarm returns to within normal limits, the display will stop flashing the alarm.

There are no alarms for individual EGTs because the temperature values can assume different ranges depending on the flight configuration—run up, climb, and cruise. However there is an alarm on the DIF parameter, the difference between the hottest and coolest EGTs. DIF - or span - is the important parameter for monitoring the EGTs.

When an alarm is displayed, *tapping* the STEP button will temporarily disable the alarm digital indication for the next ten minutes.

When an alarm is displayed, *holding* the STEP button until the word OFF appears will disable that alarm digital indication for the remainder of the flight.

9.4.9.1 Alarm Priority

If multiple alarms occur simultaneously, the higher priority alarm will temporarily “mask” the lower priority alarm(s). When an alarm occurs, note the cause of the alarm and tap the STEP button to clear the alarm indication so that you will be notified of any other alarm that might have occurred. The alarm priorities are as follows:

Highest Priority	CHT	High CHT
	CLD	Excessive CHT cooling rate
	DIF	Excessive EGT Span
	BAT	High or Low Battery Voltage
	LO	Low fuel quantity remaining
	FUEL	
Lowest priority	LO	Low fuel endurance remaining
	TIME	

9.4.9.2 Pre-Ignition and Detonation

Combustion that occurs too rapidly leads to detonation and possibly pre-ignition. Detonation is abnormally rapid combustion where the fuel-air mixture explodes instead of burning uniformly. It causes the EGT to decrease and the CHT to increase, and can appear during the leaning process.

Detonation may occur under conditions of high compression resulting from fuel with too low an octane rating, or from avgas contaminated by jet fuel. Fuel additives, such as lead, boost the octane rating and slow down the combustion process, producing an even pressure on the piston.

Pre-ignition is caused by hot spots in the cylinder. Ignition occurs prior to the spark plug firing. The EDM depicts pre-ignition as a sudden large increase of the EGT. This may occur in one or more cylinders. The affected

cylinder column(s) will flash while an EGT higher than 2000°F will be displayed.

WARNING
At temperatures exceeding 2000°F pre-ignition will destroy the engine in less than a minute unless you take immediate corrective action.

9.4.10 Parameter Scan

Listed below are the sequence, parameter description and example of the display.

Select Switch	Parameter Description	Example	Comments
T, A	Voltage, System Bus	14.2 BAT	Battery voltage
T, A	Difference between hottest and coldest EGT	80 DIF	Dot indicates most widely deviating cylinder
T, A, F	RPM	2450 RPM	RPM
T, A, F	MAP	23.1 MAP	Manifold pressure
F, A	Fuel Remaining	37.2 REM	In gallons, liters or pounds or kilograms
F, A	Fuel required to next GPS WPT or Destination	25.9 REQ	Present with GPS interface Valid signal and way point
F, A	Nautical Miles per Gal	13.0 MPG	Present with GPS interface and valid signal or MPK, MPL, MPP
F, A	Time to Empty	02.45 H.M.	Hours, Minutes Remaining at current fuel burn
F, A	Fuel Flow Rate	13.5 GPH	Or KPH, LPH, PPH

Select Switch	Parameter Description	Example	Comments
T, A	Voltage, System Bus	14.2 BAT	Battery voltage
F, A	Total Fuel Used	38 USD	Since last refueling or trip total.
F, A	EGT, CHT	1340 376	EGT, left, CHT, right. Dot indicates cylinder

Table 9-4-3 Display Examples

9.4.11 Engine Diagnosis Chart

The following chart will help you diagnose engine problems in your aircraft (views are percentage views). Notice there will always be one CHT that is shown hotter than the others.

Display	Sympton	Probable Cause	Recommended Action
<p>— CHT 500 — 400 — 300 —</p>	75° to 100° EGT rise for one cylinder during flight	Spark plug not firing due to fouling, faulty plug, wire or distributor.	Enrich mixture to return EGT to normal. Have plugs checked.
<p>— CHT 500 — 400 — 300 —</p>	EGT Increase or decrease after ignition system maintenace	Improper timing: high EGT→ retarded ignition; low EGT→ advanced igation.	Check EGT for each magneto to determine any uneven timing.
<p>— CHT 500 — 400 — 300 —</p>	Loss of EGT for one cylinder. Engine rough	Stuck valve. Other cylinders are okay.	Have valve train checked.
<p>— CHT 500 — 400 — 300 —</p>	Loss of EGT for one cylinder; no digital EGT	Failed probe or failed wire harness.	Swap probes to determine if probe or wire harness is bad.
<p>— CHT 500 — 400 — 300 —</p>	Decrease in EGT for one cylinder	Intake valve not opening fully; faulty valve lifter.	Have valve lifter or rocker arm checked.
<p>— CHT 500 — 400 — 300 —</p>	Increase in DIF (Excessive EGT span) at low RPM	Low compression (blow by) in cylinder	Check compression.

Table 9-4-4 Engine Diagnosis Chart 1

Display	Symptom	Probable Cause	Recommended Action
	EGT and CHT not uniform	Fouled plugs	Check plugs. Non-uniformity is normal for carbureted engines
	Decrease in EGT for all cylinders	Decrease in airflow into the induction system, Carb or induction ice Engine units set to Celsius	Check for change in manifold pressure Check that the alarm limits are set to Celsius degrees
	Slow rise in EGT. Low CHT	Burned exhaust valve. CHT is low due to low power output	Have compression checked
	High CHT on cylinders on one side of engine	Obstruction under cowling	Check for improper installed baffling, cowl flap misalignment or bird nests
	Rapid rise in CHT of one cylinder	Detonation	Reduce power
	Sudden off scale rise for any or all cylinders	Pre-ignition or Normalize view or failed probe	Full rich and reduce power Change to Percentage view Check probe

Table 9-4-5 Engine Diagnosis Chart 2

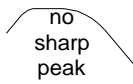
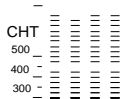
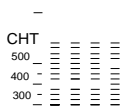
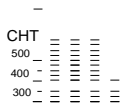
Display	Sympton	Probable Cause	Recommended Action
	Loss of peak EGT	Poor ignition.	Have magneto tested.
	Decrease in peak or flat EGT response to leaning process	Detonation. Usually the result of 80 Octane fuel in 100 Octane engine.	Enrich mixture, reduce power and relean mixture. Repeat to find power setting where normal peak is obtained or run rich.
	Below 10,000 ft. full throttle causes EGTs to rise	Weak or defective mechanical fuel pump.	Apply booster pump. If EGTs drop, replace fuel pump.
	CHT more than 500°, EGT normal. Adjacent EGT may be low	Leaking exhaust gasket blowing on CHT probe.	Look for white powder around cylinder to determine leak area.
	Large DIF (Excessive EGT span) at low RPM	Blow by in cylinder rings.	Check compression.

Table 9-4-6 Engine Diagnosis Chart 3

INTENTIONALLY LEFT BLANK

9.5 GARMIN GNS 530 COM/NAV

9.5.1 GENERAL

This supplement must be attached to the Pilot's Operating Handbook and FAA Approved Airplane Flight Manual when the Garmin GNS 530 is installed per the Equipment List supplied with the aircraft and listed in Section 6 of this manual. The information contained herein supplements or supersedes the basic Pilot's Operating Handbook and FAA Approved Flight Manual only in those areas listed in this supplement. For limitations, procedures and performance information not contained in this supplement, consult Section 2 of this Pilot's Operating Handbook and FAA Approved Airplane Flight Manual.

This supplement has been FAA approved as a permanent part of the handbook and must remain in the handbook at all times when the Garmin GNS 530 is installed.

9.5.1.1 DESCRIPTION

The GNS 530 System is a fully integrated, panel mounted instrument, which contains a VHF Communications Transceiver, a VOR/ILS receiver, and a Global Positioning System (GPS) Navigation computer and a Terrain Awareness and Warning System (TAWS or TERRAIN). The system consists of a GPS antenna, GPS Receiver, VHF VOR/LOC/GS antenna, VOR/ILS receiver, VHF COMM antenna and a VHF Communications Transceiver. The primary function of the VHF Communication portion of the equipment is to facilitate communication with Air Traffic Control. The primary function of the VOR/ILS Receiver portion of the equipment is to receive and demodulate VOR, Localizer, and Glide Slope signals. The primary function of the GPS

portion of the system is to acquire signals from the GPS system satellites, recover orbital data, make range and Doppler measurements, and process this information in real-time to obtain the user's position, velocity, and time. The primary function of the TAWS or TERRAIN portion of the system is to provide terrain situational awareness.

Provided the Garmin GNS 530's GPS receiver is receiving adequate usable signals, it has been demonstrated capable of and has been shown to meet the accuracy specifications for:

- VFR/IFR enroute, terminal, and non-precision instrument approach (GPS, Loran-C, VOR, VOR-DME, TACAN, NDB, NDB-DME, RNAV) operation within the U.S. National Airspace System in accordance with AC 20-138.
- One of the approved sensors, for a single or dual GNS 530 installation, for North Atlantic Minimum Navigation Performance Specification (MNPS) Airspace in accordance with AC 91-49 and AC 120-33.
- The system meets RNP5 airspace (BRNAV) requirements of AC 90-96 and in accordance with AC 20-138 and JAA GAI-20 ACJ 20X4, provided it is receiving usable navigation information from the GPS receiver.
- The equipment as installed has been found to comply with the requirements for GPS primary means of navigation in oceanic and remote airspace, when used in conjunction with the 500 Series Trainer Program incorporating the FDE Prediction Program. This does not constitute an operational approval.

Navigation is accomplished using the WGS-84 (NAD-83) coordinate reference datum. Navigation data is based upon use of only the Global Positioning System (GPS) operated by the United States of America.

9.5.2 LIMITATIONS

The Garmin GNS 530 Pilot's Guide, P/N 190-00181-00, Rev. A, dated April 2000 or later appropriate revision must be immediately available to the flight crew whenever navigation is predicated on the use of the system.

In addition to the Pilot's Guide, the appropriate Pilot's Guide Addendum also must be immediately available to the flight crew if lightning detection, Weather Datalink, Traffic Advisory System (TAS), Traffic Information Service (TIS), TAWS, or TERRAIN is interfaced to the system or if primary means oceanic/remote navigation is conducted.

The GNS 530 must utilize the following or later FAA approved software versions:

Function	Sub-System Version				
	Main	GPS	COM	VOR/LOC	G/S
Initial Approval	2.00	2.00	1.22	1.25	2.00
Traffic/Weather Interface	2.00	2.00	1.22	1.25	2.00
Primary Oceanic/Remote	3.00	3.00	1.22	1.25	2.00
TIS Interface	4.00	2.00	1.22	1.25	2.00
TAWS	5.02	3.01	6.00	3.01	2.03
TERRAIN	6.01	3.01	6.00	3.01	2.03

The Main software version is displayed on the GNS 530 self test page immediately after turn-on for five seconds. The remaining system software versions can be verified

on the AUX group sub-page 2, “Software / Database Versions”.

If not previously defined, the following default settings must be made in the “AUX Pages, SETUP Page, UNITS/POSITION” menu of the GNS 530 prior to operation (refer to Pilot's Guide for procedure if necessary):

- **dis, spd:** nm, kt or mi, mph (sets navigation units to “nautical miles” and “knots” or “statute miles” and “mph”)
- **alt, vs:** ft fpm (sets altitude units to “feet” and “feet per minute”)
- **map datum:**WGS 84 (sets map datum to WGS-84, see note below)
- **posn:** deg-min (sets navigation grid units to decimal minutes)

NOTE

In some areas outside the United States, datums other than WGS-84 or NAD-83 may be used. If the GNS 530 is authorized for use by the appropriate Airworthiness authority, the required geodetic datum must be set in the GNS 530 prior to its use for navigation.

Navigation must not be predicated upon the use of the TAWS or TERRAIN.

CAUTION

The terrain display is intended to serve as a situational awareness tool only. It may not provide either the accuracy or fidelity, or both, on which to solely base decisions and plan maneuvers to avoid terrain or obstacles.

To avoid giving unwanted alerts, the TAWS or TERRAIN must be inhibited when landing at an airport that is not included in the airport database.

NOTE

Pilots are NOT authorized to deviate from their current ATC clearance to comply with terrain/obstacle warnings from a TERRAIN unit except as allowed by 14 CFR Part 91.3(b). TERRAIN warnings are advisory only and are not equivalent to warnings provided by a TAWS unit.

The TAWS/ TERRAIN databases have an area of coverage as detailed below:

- The Terrain Database has an area of coverage from North 75° Latitude to South 60° Latitude in all longitudes.
- Airport Terrain Database has an area of coverage that includes North America, and South America.
- The Obstacle Database has an area of coverage that includes the United States.

9.5.3 EMERGENCY PROCEDURES

CAUTION

This aircraft is not certified for IFR operations. The following procedures are included in this manual for advisory purposes only.

If Garmin GNS 530 navigation information is not available or invalid, utilize remaining operational navigation equipment as required. If the TAWS or TERRAIN option is installed, it will not be available. A white 'TER N/A' or red 'TER FAIL' annunciator will be displayed in the lower left corner of the GNS 530 display.

If "RAIM POSITION WARNING" message is displayed the system will flag and no longer provide GPS based navigational guidance. The crew should revert to the GNS 530 VOR/ILS receiver or an alternate means of navigation other than the GNS 530's GPS Receiver. If the TAWS or TERRAIN option is installed, it will not be available and a white 'TER N/A' status annunciator will be displayed by the GNS 530.

If "RAIM IS NOT AVAILABLE" message is displayed in the enroute, terminal, or initial approach phase of flight, continue to navigate using the GPS equipment or revert to an alternate means of navigation other than the GNS 530's GPS receiver appropriate to the route and phase of flight. When continuing to use GPS navigation, lateral position must be verified every 15 minutes using the GNS 530's VOR/ILS receiver or another IFR-approved navigation system.

If "RAIM IS NOT AVAILABLE" message is displayed while on the final approach segment, GPS based navigation will continue for up to five minutes with approach CDI sensitivity (0.3 nautical miles). After five minutes the system will flag and no longer provide course guidance with approach sensitivity. Missed approach course guidance may still be available with one nautical mile CDI sensitivity by executing the missed approach.

If the white "TER N/A" status annunciator is displayed by the GNS 530, the system will no longer provide TAWS or TERRAIN alerting or display relative terrain elevations. The crew must maintain compliance with procedures that ensure minimum terrain separation.

If the red "TER FAIL" status annunciator is displayed by the GNS 530, the system will no longer provide TAWS or TERRAIN alerting or display relative terrain elevations. The crew must maintain compliance with procedures that ensure minimum terrain separation.

If a "TAWS has failed" or a "TERRAIN has failed" message is displayed by the GNS 530, the system will no longer provide TAWS or TERRAIN alerting or display relative terrain elevations. The crew must maintain compliance with procedures that ensure minimum terrain separation.

9.5.4 NORMAL PROCEDURES

9.5.4.1 DETAILED OPERATING PROCEDURES

Normal operating procedures are described in the Garmin GNS 530 Pilot's Guide, P/N 190-00181-00, Rev. A, dated April 2000 or later appropriate revision.

9.5.4.2 PILOT'S DISPLAY

The GNS 530 System data will appear on the Pilot's CDI/HSI. The source of data is either GPS or VLOC as annunciated on the display above the CDI key.

NOTE

It is the pilot's responsibility to assure that published or assigned procedures are correctly complied with. Course guidance is not provided for all possible ARINC 424 leg types. See the GNS 530 Pilot's Guide for detailed operating procedures regarding navigation capabilities for specific ARINC 424 leg types.

9.5.4.3 AUTOMATIC LOCALIZER COURSE CAPTURE

This feature provides a method for system navigation data present on the external indicators to be switched from GPS guidance to localizer / glide slope guidance. The data is found via the Jeppeson data card and tuned manually. It is the pilot's responsibility to ensure correct system navigation data is present on the external indicator before continuing a localizer based approach beyond the final approach fix. Refer to the GNS 530 Pilot's Guide for detailed operating instructions.

9.5.4.4 DISPLAY OF LIGHTNING STRIKE DATA

For installations that interface the BF Goodrich WX-500 Stormscope and the GNS 530, lightning strike data detected by the WX-500 will appear on the GNS 530. For detailed operating instructions regarding the interface of the GNS 530 with the WX-500, refer to the WX-500 Pilot's Guide and the GNS 530 Pilot's Guide for the WX-500 Stormscope interface.

9.5.4.5 DISPLAY OF TRAFFIC ADVISORY DATA

For installations that interface a Traffic Advisory System (TAS) and the GNS 530, traffic data detected by the TAS will appear on the GNS 530. For detailed operating instructions regarding the interface of the GNS 530 with the TAS, refer to the FAA Approved Flight Manual Supplement for the TAS, the Pilot's Guide for the TAS and the GNS 530 Pilot's Guide.

9.5.4.6 DISPLAY OF TRAFFIC INFORMATION SERVICE DATA

TIS surveillance data uplinked by Air Traffic Control (ATC) radar through the GTX 330 Mode S Transponder will appear on the moving map and traffic display pages of the GNS 530. For detailed operating instructions regarding the interface of the GNS 530 with the GTX 330, refer to the GNS 530 Pilot's Guide Addendum for the TIS System interface.

9.5.4.7 TERRAIN AWARENESS CAUTION

When a terrain awareness CAUTION occurs, take positive corrective action until the alert ceases. Stop descending or initiate either a climb or a turn, or both, as necessary, based on analysis of all available instruments and information.

9.5.4.8 TERRAIN AWARENESS WARNING

If a terrain awareness WARNING occurs, immediately initiate and continue a climb that will provide maximum terrain clearance, or any similar approved vertical terrain escape maneuver, until all alerts cease. Only vertical maneuvers are recommended, unless either operating in visual meteorological conditions (VMC), unless the pilot determines, that turning in addition to the vertical escape maneuver, is the safest course of action.

9.5.4.9 TERRAIN INHIBIT

The TAWS and TERRAIN Forward Looking Terrain Avoidance (FLTA) and Premature Descent Alerts (PDA) functions may be inhibited to stop alerting for acceptable flight conditions (such as below glideslope maneuvers). For detailed operating instructions regarding the GNS 530 TAWS or TERRAIN interface, refer to the 400/500 Series Garmin Optional Displays Pilot's Guide Addendum, P/N 190-00140-13.

9.5.5 PERFORMANCE

No change.

9.5.6 WEIGHT AND BALANCE

The Garmin 530 was installed at the factory and is included in the licensed weight and balance information in section 6 of the Pilot's Operating Handbook and FAA Approved Airplane Flight Manual.

9.6 GARMIN GTX 330 TRANSPONDER

9.6.1 GENERAL

This supplement must be attached to the Pilot's Operating Handbook and FAA Approved Airplane Flight Manual when the Garmin GTX 330 Transponder is installed per the Equipment List supplied with the aircraft and listed in Section 6 of this manual. The information contained herein supplements or supersedes the basic Pilot's Operating Handbook and FAA Approved Flight Manual only in those areas listed in this supplement. For limitations, procedures and performance information not contained in this supplement, consult Section 2 of this Pilot's Operating Handbook and FAA Approved Airplane Flight Manual.

This supplement has been FAA approved as a permanent part of the handbook and must remain in the handbook at all times when the Garmin GTX 330 is installed.

9.6.1.1 DESCRIPTION

The GTX 330 is a solid-state Mode C digital transponder. It is TSO certified, uses a DSTN Liquid Crystal Display and a numeric keypad with a dedicated VFR code button.

The GTX 330 is Mode S, IFR-certified with data link capability, including local traffic updates. The GTX 330 is able to receive FAA Traffic Information Services (TIS), including location, direction, altitude, and climb/descent information of nearby aircraft and display the data on a GNS 530 or GNS 430, when appropriately interfaced with such equipment.

The GTX 330 also offers several timing and display functions: flight time, count-up and count down timers, and current pressure altitude. Other features include remote ident and auto standby, plus altitude monitor with voice alerting and an optional OAT (Outside Air Temperature) Probe.

NOTE

The GTX 330 meets the requirements of Level 2 Mode-S to satisfy the upcoming European Mode-S mandate for Elementary Surveillance.

9.6.2 LIMITATIONS

Installation of the GTX 330 transponder does not alter the basic limitations provided in Section 2 of this Pilot's Operating Handbook and FAA Approved Airplane Flight Manual.

9.6.3 EMERGENCY PROCEDURES

To transmit an emergency signal:

Mode selection keyALT
Code selectionSELECT 7700

To transmit a signal representing loss of all communications:

Mode selection keyALT
Code selectionSELECT 7600

9.6.4 NORMAL PROCEDURES

• **Before Takeoff**

To transmit Mode C (Altitude Reporting) code in flight:

Mode selection keyALT
Code selector keys.....SELECT assigned code

To transmit Mode A (Aircraft Identification) code in flight:
Mode selection key ON
Code selector keys SELECT assigned code

NOTE

During normal operation with the ON mode selected, the reply interrogator "R" flashes, indicating transponder replies to interrogation.

NOTE

Mode A reply codes are transmitted in ALT also; however, mode C codes only are suppressed when the Function Selector ON is chosen.

9.6.5 PERFORMANCE

No change.

9.6.6 WEIGHT AND BALANCE


The Garmin GTX 330 was installed at the factory and is included in the licensed weight and balance information in Section 6 of the Pilot's Operating Handbook and FAA Approved Airplane Flight Manual.

9.6.7 DESCRIPTION AND OPERATION

The GTX 330 transponder is powered on by pressing the **STBY**, **ALT** or **ON** keys, or by the remote avionics master switch. After the power has been turned on, a start-up page will be displayed while the unit performs a self-test.

9.6.7.1 Mode Selection Keys



- OFF** Powers off the GTX330.
- STBY** Powers on the transponder in standby mode. At power on, the last active identification code will be selected. When in standby mode, the transponder will not reply to any interrogations.
- ON** Powers on the transponder in Mode A. At power on, the last active identification code will be selected. In this mode, the transponder replies to interrogations, as indicated by the Reply Symbol on the display shown below.
-  A small square icon containing a stylized 'R' symbol, representing the Reply Symbol.
- ALT** Powers on the transponder in Mode A and Mode C. At power on, the last active identification code will be selected. In ALT mode, the transponder replies to identification and altitude interrogations, as indicated by the Reply Symbol. Replies to altitude interrogations include the standard pressure altitude received from an external altitude source, which is not adjusted for barometric pressure. The ALT mode may be used in aircraft not equipped with the optional altitude encoder; however, the reply signal will not include altitude information.

9.6.7.2 GTX 330 Configuration Mode

The GTX 330's configuration, which is normally set at the time of installation, influences many of the unit's functions described in this manual. If you wish to change any of the GTX 330 configuration parameters, you may access the GTX 330 Configuration Mode. Use caution when changing configuration. When in doubt, contact an authorized Garmin service center. The Configuration Mode should not be used while the aircraft is airborne.

To use the GTX 330 Configuration Mode:

1. Press and hold the **FUNC** key while powering on the unit using the **STBY**, **ALT** or **ON** keys (or using the avionics master switch).
2. Press the **FUNC** key to sequence through the configuration pages.
3. Use the **CRSR** key to highlight the selectable fields on each page.
4. When a field is highlighted, enter numeric data using the **0-9** keys, and select items from a list using the **8** or **9** keys.
5. Press the **CRSR** key to confirm list selections.

9.6.7.3 Code Selection



Code selection is done with eight keys (**0-7**) that provide 4,096 active identification codes. Pushing one of these keys begins the code selection sequence. The new code will not be activated until the fourth digit is entered. Pressing the **CLR** key will move the cursor back to the previous digit.

Pressing the **CLR** key when the cursor is on the first digit of the code, or pressing the **CRSR** key during code entry will remove the cursor and cancel the data entry, restoring the previous code. The numbers **8** and **9** are not used for code entry, only for entering Count Down time, and in the Configuration Mode.

Important Codes:

- 1200** The VFR code for any altitude in the USA (Refer to ICAO standards elsewhere)
- 7000** The VFR code commonly used in Europe (Refer to ICAO standards)
- 7500** Hijack code (Aircraft subject to unlawful interference)
- 7600** Loss of communications
- 7700** Emergency
- 7777** Military interceptor operations (Never squawk this code)
- 0000** Military use (Not enterable)

Care should be taken not to select the code 7500 and all codes in the 7600-7777 range, which will trigger special indicators in automated facilities. Only the code 7500 will be decoded as the hijack code. An aircraft's transponder code (when available) is utilized to enhance the tracking capabilities of the ATC facility, Therefore, care should be taken when making routine code changes.

9.6.7.4 Keys for other GTX 330 Functions



IDENT- Pressing the IDENT key activates the Special Position Identification (SPI) Pulse for 18 seconds, identifying your transponder return on the air traffic controller's screen. The word "IDENT" will appear in the upper left corner of the display while the IDENT mode is active.



VFR- Sets the transponder code to the pre-programmed code selected in the Configuration Mode (this is set to 1200 at the factory). Pressing the **VFR** key again will restore the previous identification code.



FUNC- Changes the page shown on the right side of the display. Displayed data includes Pressure Altitude, Flight Time, Altitude Monitor, Count Up timer and Count Down timer.



START/STOP- Starts and stops the Count Up and Count Down timers and Flight Timers



CRSR- Initiates entry of the starting time for the Count Down timer and cancels transponder code entry.



CLR- Resets the Count Up and Count Down timers and cancels the previous key press during code selection and Count Down entry. Returns the cursor to the fourth code digit within five seconds of entry.





8- Reduces Contrast and Display Brightness when the respective fields are displayed. Also enters the number 8 into the Count Down timer.





9- Increases Contrast and Display Brightness when the respective fields are displayed. Also enters the number 9 into the Count Down timer.

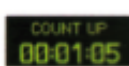
9.6.7.5 Function Display Indicator

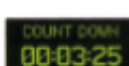
 PRESSURE ALT: Displays the altitude data supplied to the GTX 330 in hundreds of feet (i.e. flight level) or metres, depending on configuration.


 FLIGHT TIME: Timer start is configured as either Manual or Automatic. When Manual, displays the Flight Time, controlled by the START/STOP and CLR keys. When Automatic, the timer begins when takeoff is sensed.


 ALTITUDE MONITOR: Controlled by START/STOP key. Activates a voice alarm and warning annunciator when altitude is exceeded.

 OAT/DALT: Displayed when the GTX 330 is configured with temperature input. Displays Outside Air Temperature and Density Altitude.

 COUNT UP TIMER: Controlled by START/STOP and CLR keys.

 COUNT DOWN TIMER: Controlled by START/STOP and CRSR keys. The initial Count Down time is entered with the 0-9 keys.

 CONTRAST: This page is only displayed if manual contrast mode is selected in Configuration Mode. Contrast is controlled by the 8 and 9 keys.

 DISPLAY: This page is only displayed if manual backlighting mode is selected in Configuration Mode. Backlighting is controlled by the 8 and 9 keys.

9.6.7.6 Altitude Trend Indicator

When the “PRESSURE ALT” page is displayed, an arrow may be displayed to the right of the altitude, indicating that the altitude is increasing or decreasing. One of two sizes of arrows may be displayed depending on the rate of climb/descent. The sensitivity of these arrows is set using the GTX Configuration Mode.

9.6.7.7 Timer Operation

To operate the flight timer:

1. Press the **FUNC** key until “FLIGHT TIME” is displayed.
2. If desired, you may press **START/STOP** to pause or restart the timer.
3. Press **CLR** to reset the timer to zero.

To operate the Count Up timer:

1. Press the **FUNC** key until “COUNT UP” is displayed.
2. If necessary, press **CLR** to reset the Count Up timer to zero.
3. Press **START/STOP** to count up.
4. Press **START/STOP** again to pause the timer.
5. Press **CLR** to reset the timer to zero.

To operate the Count Down timer:

1. Press the **FUNC** key until “COUNT DOWN” is displayed.
2. Press **CRSR** and use the **0-9** keys to set the initial time. All digits must be entered (use the 0 key to enter leading zeros).
3. Press **START/STOP** to count down.
4. Press **START/STOP** again to pause the timer.
5. When the Count Down timer expires, the words “COUNT DOWN” are replaced with “EXPIRED” and the time begins counting up and flashing.
6. Press **CLR** to reset the timer to the initial time value.

9.6.7.8 Failure Annunciation

If the unit detects an internal failure, the screen displays FAIL. When FAIL is annunciated no transponder data is transmitted.

9.6.7.9 Traffic Information Service

The GTX 330 provides a data link for Traffic Information Service (TIS). TIS is derived through a Mode S transponder data link and viewed on a multifunction display. ATC radar sends a traffic picture within a radius of 55 miles from select sites. The TIS protected area is a cylinder of 7 miles radius, extending 3500' above and 3000' below the aircraft. Refer to the AIM Chapter 1 for more details.

TIS provides a graphic display of traffic information in the cockpit for non-TCAS equipped aircraft. Transponder equipped aircraft can be displayed within the coverage volume within range of the aircraft's position on indicators such as a Garmin 430 or 530 and MX20. Aircraft without an operating transponder are invisible to TIS. Refer to Garmin 400/500 series, GNS480 or MX20 pilot literature for details.

9.6.7.10 Audio Alerts

(Setting options; male/female voice or tone and volume level)

- "Leaving Altitude" Altitude deviation is exceeded.
- "Traffic" TIS traffic is received.
- "Traffic Not Available" TIS service is not available or out of range.
- "Timer Expired" for countdown time.

9.6.7.11 OAT Probe

If installed pressing the Function Button until OAT TEMP appears will give you the Outside Air Temperature.

9.7 GARMIN GMA 340 AUDIO PANEL

9.7.1 GENERAL

This supplement must be attached to the Pilot's Operating Handbook and FAA Approved Airplane Flight Manual when the Garmin GMA 340 Audio Panel is installed, per the Equipment List supplied with the aircraft and listed in Section 6 of this manual. The information contained herein supplements or supersedes the basic Pilot's Operating Handbook and FAA Approved Flight Manual only in those areas listed in this supplement. For limitations, procedures and performance information not contained in this supplement, consult Section 2 of this Pilot's Operating Handbook and FAA Approved Airplane Flight Manual.

This supplement has been FAA approved as a permanent part of the handbook and must remain in the handbook at all times when the Garmin GMA 340 Audio Panel is installed.

9.7.1.1 DESCRIPTION

The GMA 340 is an audio panel that provides audio switching function between the different avionics installed in the aircraft. It has LED-illuminated push button controls that allow audio selection of both NAV and Comm audio. Each microphone input has a dedicated VOX circuit to ensure that only the active microphone is heard when squelch is broken. Special cabin noise de-emphasis circuitry enhances cockpit communications. It also has the three-light Marker Beacon Receiver/Indicator with high/low sensitivity selection.

9.7.2 LIMITATIONS

Installation of the GMA 340 Audio Panel does not alter the basic limitations provided in Section 2 of this Pilot's Operating Handbook and FAA Approved Airplane Flight Manual.

9.7.3 EMERGENCY PROCEDURES

There are no emergency procedures associated with the GMA 340 system.

9.7.4 NORMAL PROCEDURES

9.7.4.1 AUDIO CONTROL SYSTEM OPERATIONS

Select the desired transmitter audio selector button (COM1, COM2 or COM3) and verify that the button's LED is illuminated.

Adjust the INTERCOM VOL Control (ICS) to the desired listening level.

Adjust the INTERCOM VOX (voice) sensitivity control by rotating the control knob clockwise to the middle range and adjust as required for the desired voice activation or hot mic intercom.

<p style="text-align: center;">NOTE</p>
--

<p style="text-align: center;">Audio level is controlled by the selected NAV radio volume control</p>

9.7.4.2 MARKER BEACON RECEIVERS

Press the test button to verify that all marker beacon lights are operational.

Select sensitivity, HI for airway flying and LO for ILS/LOC approaches.

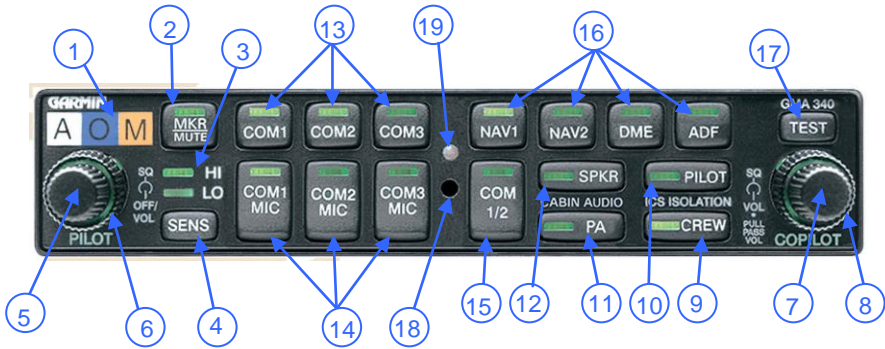
9.7.5 PERFORMANCE

No change.

9.7.6 WEIGHT AND BALANCE

The GMA 340 was installed at the factory and is included in the licensed weight and balance information in Section 6 of the Pilot's Operating Handbook and FAA Approved Airplane Flight Manual

9.7.7 DESCRIPTION AND OPERATION



MKR BCN	1	Marker Beacon Lamps
	2	Marker Beacon Receiver Audio Select/Mute Button
	3	Marker Beacon Receiver Sensitivity Selection Indicator LED
	4	Marker Beacon Receiver Sensitivity Selection Button
ICS	5	Unit ON/OFF, Pilot Intercom System (ICS) Volume
	6	Pilot ICS Voice Actuated (VOX) Intercom Squelch Level
	7	Copilot ICS Volume Control
	8	Copilot VOX Intercom Squelch Level
	9	Crew Isolation Intercom Mode Button
	10	Pilot Isolation Intercom Mode Button
COM/ NAV	11	Passenger Address (PA) Function Button
	12	Speaker Function Button
	13	Transceiver Audio Selector Buttons (COM1, COM2, COM3)
	14	Transmitter (Audio/Mic) Selection Buttons
	15	Split COM Button
	16	Aircraft Radio Audio Selection Buttons (NAV1, NAV2)
	17	Annunciator Test Button
	18	Photocell Automatic Annunciator Dimming
	19	Transmission Indicator Light

9.7.7.1 ON/OFF, PILOT INTERCOM SYSTEM (ICS) VOLUME CONTROL

To turn the GMA 340 ON rotate the small knob, ^⑤, past the click. The knob then functions as the pilot's ICS volume control. A fail-safe circuit connects the pilot's headset and microphone directly to COM1 if the power is interrupted or the unit is turned off.

9.7.7.2 TRANSCEIVERS

Both MIC and audio source may be selected by pressing any of the buttons labeled, ^⑭, (COM1 MIC, COM2 MIC, COM3 MIC). The active COM audio is always heard on the headphones.

In addition, each audio source can be selected independently by pressing COM1, COM2 or COM3, ^⑬. When selected in this way, they remain active as audio sources regardless of which transceiver has been selected for transmission.

When a microphone is keyed, the active transceiver's MIC button LED will blink for approximately one second to indicate that the radio is transmitting.

NOTE

Audio level is controlled by the selected NAV radio volume control.

9.7.7.3 Split COM

Pressing the COM 1/2 button, ^⑮, activates the split COM functions. When this mode is active, COM1 is dedicated solely to the pilot for MIC/Audio, while COM2 is dedicated to the copilot for MIC/Audio. The pilot and copilot can simultaneously transmit in this mode over separate radios. Both pilots can still listen to COM3, NAV1, NAV2 and MKR as selected. The split COM mode is cancelled by pressing the COM1/2 button a second time.

9.7.7.4 Aircraft Radios and Navigation

Pressing NAV1, NAV2, ⑬, or MKR, ⑭, selects each audio source. A second button press cancels the selection.

9.7.7.5 Auxiliary Entertainment Inputs

The GMA 340 provides two stereo entertainment inputs: MUSIC1 and MUSIC 2. MUSIC 1 is soft-muted during all aircraft radio activity and normally during ICS activity. MUSIC2 is a non-muted input. These inputs are compatible with popular portable entertainment devices such as CD players. The headphone outputs of these devices should be used to plug into MUSIC1 or MUSIC2. Two 3.5 mm stereo jacks should be installed in a convenient location for this purpose.

9.7.7.6 Intercom System (ICS)

NOTE

As the CC18-180 is a two-seat aircraft, the functions that relate to passengers are not enabled.

The intercom volume and squelch (VOX) are adjusted using the following front panel knobs:

Left Small Knob	Unit ON/OFF power control and pilot's ICS volume. Full CCW detent position is OFF
Left Large Knob	Pilot's ICS mic VOX squelch level. CW rotation increases the amount of mic audio (VOX level) required to break squelch. Full CCW is the "HOT MIC" position (no squelch)
Right Small Knob	IN position: Copilot ICS volume. OUT position: passenger ICS volume

Right Large Knob	Copilot mic VOX squelch level. CW rotation increases the amount of mic audio (VOX level) required to break squelch. Full CCW is the "HOT MIC" position (no squelch)
PILOT Mode	This mode isolates the pilot from everyone else and dedicates the aircraft's radios exclusively to the pilot. The copilot cannot communicate with the pilot or hear the aircraft's radios

9.7.7.7 Marker Beacon Receiver

The GMA 340's marker beacon receiver controls are located on the left side of the front panel (1-4). The SENS button selects either high or low sensitivity as indicated by the HI or LO LED being lit. Low sensitivity is used on ILS approaches while high sensitivity allows operation over airway markers or to get an earlier indication that the aircraft is nearing the outer marker during an approach.

The marker audio is initially selected by pressing the MKR/Mute button (2). If no beacon signal is received, then pressing the button a second time will de-select the marker audio. This operation is similar to the selection of any other audio source on the GMA 340. However, if the button is pressed for the second time while a marker beacon signal is being received, then the marker audio is muted but not de-selected. The button's LED will remain lit to indicate that the source is still selected. When the current marker signal is no longer being received, the muting of the audio will be cancelled. While in the muted state, pressing the MKR/Mute button de-selects the marker audio. The button's LED will extinguish to indicate that the marker audio is no longer selected.

INTENTIONALLY LEFT BLANK

**9.8 PS ENGINEERING PXE7300 IN FLIGHT
ENTERTAINMENT SYSTEM**

9.8.1 GENERAL

This supplement must be attached to the Pilot's Operating Handbook and FAA Approved Airplane Flight Manual when the PS Engineering PXE7300 in-flight entertainment system is installed, per the Equipment List supplied with the aircraft and listed in Section 6 of this manual. The information contained herein supplements or supersedes the basic Pilot's Operating Handbook and FAA Approved Flight Manual only in those areas listed in this supplement. For limitations, procedures and performance information not contained in this supplement, consult Section 2 of this Pilot's Operating Handbook and FAA Approved Airplane Flight Manual.

This supplement has been FAA approved as a permanent part of the handbook and must remain in the handbook at all times when the PS Engineering PXE7300 in-flight entertainment system is installed.

9.8.1.1 DESCRIPTION



- | | |
|-------------------------|--------------------|
| 1. Power/Volume control | 5. MODE Button |
| 2. Stop/Eject Button | 6. Data Knob |
| 3. Play/Pause Button | 7. Display Dimming |
| 4. R/S Button | |

9.8.2 LIMITATIONS

Installation of the PXE7300 system does not alter the basic limitations provided in Section 2 of this Pilot's Operating Handbook and FAA Approved Airplane Flight Manual.

9.8.3 EMERGENCY PROCEDURES

There are no emergency procedures associated with the PXE7300 system.

9.8.4 NORMAL PROCEDURES

The single-disc player is designed for simple operation. The disc player will begin to play automatically when a disc is inserted (unless the disc is specially formatted as 7300 volume, see section of special functions). The disc will play through in order, and then stop at the end. If a disc is not inserted, the unit will be in the FM radio mode.

Note: When a disc is inserted, the display will show "Reading..." for up to 20 seconds, depending on the media and amount of information contained.

9.8.5 PERFORMANCE

No change.

9.8.6 WEIGHT AND BALANCE

The PXE7300 was installed at the factory and is included in the licensed weight and balance information in Section 6 of the Pilot's Operating Handbook and FAA Approved Airplane Flight Manual.

9.8.7 DESCRIPTION AND OPERATION

Operating controls consist of two rotary knobs with push-switches, and four buttons.

9.8.7.1 Power/Volume Control (1)

The PXE7300 system is turned on and off by pushing the volume (left hand) knob. When the unit is first turned on, the green indicator lights should flash in sequence top to bottom and left to right.

The left knob is the volume control. Turning the knob clockwise will increase the volume.

9.8.7.2 Stop/Eject Button (2)

The Stop/Eject button will stop the disc. Hold for 3 seconds to eject the disc.

In AM or FM radio mode, this button scans up the frequency band for a strong signal.

9.8.7.3 Play/Pause Button (3)

Pressing the play/pause button momentarily will pause the player. Hold to advance the track. Momentarily pressing STOP/EJECT & PLAY PAUSE buttons at the same time will cause the track to jump backward.

Action	Disc Result	Radio Result
▲ short press	Stop	Frequency Scan UP
▲ long press	Eject (also in AUX)	
▶ short press	Pause	Frequency Scan Down
▶ long press	Select next track/file and keep playing or a random track if in the random mode	
MODE press	Change from FM to AM, to SR, AUX to (if enabled) to DISC	
R/S press	Toggle into Random or Sequence play	Enter the preset "Set" mode
DATA knob CW	Select next track and play	Increase radio frequency or preset channel
DATA knob CCW	Select previous track and keep playing	Decrease radio frequency or preset channel
DATA knob Push -short press	Show data on file if available)	Enter Pre-select Frequency Recall Mode

In AM or FM radio mode, this button scans down the frequency band for a strong signal.

9.8.7.4 R/S Button (4)

This selects random play in the disc mode.

9.8.7.5 MODE Button (5)

This button cycles through the operating modes, Disc, FM, AM, Satellite (SR if present) and AUX (if enabled).

Radio Preset Function

The PXE7300 can save up to nine AM/FM stations for future recall.

To set, press the "R/S" button. The next available slot will be displayed as "S#." (# being the available memory location). Within five seconds, select the desired frequency using either the DATA knob, or the frequency scan up or down buttons. Press the R/S again to save the selection. The display will flash, indicating a successful save.

To access the channel: press the DATA knob the radio mode, and select the preset with the DATA knob or scan Up and Down buttons.

9.8.7.6 Data Knob (6)

In the Disc mode (CD or MP3), the knob will advance (CW) or decrease (CCW) the track. Track number is displayed when the knob is in motion. Then it will display the track name and begin to play.

In AM or FM radio mode, this knob can be used to tune the radio directly.

If the playing media is an MP3 format, pushing the DATA knob will display the available data from the playing tracks in sequence when the knob is pushed.

- Song Name
- MP3 Actual File Name
- Album
- Artist

Depending on the total size of the information stored on the disc, the available data may be truncated in the following manner: Small number of files, Actual File Name, Larger number of files, Truncated File Name, Most files, Track Number.

9.8.7.7 Display Dimming (7)

The display is automatically adjusted for ambient light conditions by a photocell. The range can be further adjusted by the aircraft dimmer circuit.

Appendix A: MP3 Creation

Creating MP3s from an Audio CD

1. Start MusicMatch JukeBox. (www.musicmatch.com)
Press the recorder button, which is the small red dot located in the top right corner. This will open the recorder window located at the bottom of the screen.
2. Insert an audio CD into the CD drive. MusicMatch will automatically read the disc and display the contents in the recorder window. Press the REFRESH button to check the Internet database for CD information, such as artist, song title, or album. If this information is available, it will automatically be updated in the file.
3. Select Options->Recorder->Format and select either MP3 or MP3PRO format. You may also set the MP3 file quality under the Options->Recorder->Quality menu.
4. Select the tracks to be copied to MusicMatch by checking the box next to the desired track. Press the record button in the lower left corner when complete.
5. MusicMatch will then convert the files from the audio CD to MP3 and display them in the Music Library box located in the middle of the screen.
6. To edit the MP3 information, select a file in the Music Library and press the TAG button in the top right corner of the Music Library box. This will display the MP3 tagged information screen. Select the General

tab to show the information that can be modified for the PXE 7300.

7. The PXE7300 can display song name, artist, album, and filename. This corresponds to the Track title, Artist, Album, and Track file name fields shown on the screen. Each of these fields can be modified to the user's preference.

NOTE

The PXE7300 is limited to displaying up to 22 characters in each of these fields. Click on the appropriate field to modify the track title, artist, or album. To modify the file name, select the Rename Files button in the lower left corner. Click on the field labeled New File Name and press OK to change the file name. Press the Apply and OK buttons to update the information.

Appendix B: Error Codes

In the unlikely event that you insert an invalid disc media, a scratched or dirty disc, or the unit behaves abnormally, please consult the list of error codes.

Error Code	Description
00 to 05	Timeout
09	Manual Eject (Press Stop while powering on)
21	Command not defined
22	Illegal parameter
23	Sledge error
24	Focus error
25	Spindle motor error
26	Radial error
27	PLL error
28	Subcode timeout error 1
29	Requested subcode not found error
2B	Toc read error
2C	Jump error
2D	HF error
2E	CD decoder hardware error
31	CA decoder data error
32	CA decoder hardware error
33	Flash saving error
34	Flash reading failure
35	General system error
36	Loading decoder swap file error
37	Internal decoder communication problem
38	Internal memory filemap error
80	Loader error
90	Mechanism error / invalid media

INTENTIONALLY LEFT BLANK

9.9 OPTIONAL INSTRUMENT PANEL AND VACUUM SYSTEM

9.9.1 GENERAL

This supplement must be attached to the Pilot's Operating Handbook and FAA Approved Airplane Flight Manual when the optional instrument panel and vacuum system are installed, per the Equipment List supplied with the aircraft and listed in Section 6 of this manual. The information contained herein supplements or supersedes the basic Pilot's Operating Handbook and FAA Approved Flight Manual only in those areas listed in this supplement. For limitations, procedures and performance information not contained in this supplement, consult Section 2 of this Pilot's Operating Handbook and FAA Approved Airplane Flight Manual.

This supplement has been FAA approved as a permanent part of the handbook and must remain in the handbook at all times when the optional instrument panel and vacuum system is installed.

9.9.1.1 DESCRIPTION

9.9.2 LIMITATIONS

Installation of the optional instrument panel and vacuum system does not alter the basic limitations provided in Section 2 of this Pilot's Operating Handbook and FAA Approved Airplane Flight Manual.

9.9.3 EMERGENCY PROCEDURES

There are no emergency procedures associated with the optional instrument panel and vacuum system.

CAUTION
The CC18-180 is not approved for IFR flight. Therefore, any failure of the vacuum system or any of the gyro gauges should not lead to an in-flight emergency.

9.9.4 NORMAL PROCEDURES

Before Takeoff

Vacuum pressure 4.8 to 5.2 in. Hg

9.9.5 PERFORMANCE

No change.

9.9.6 WEIGHT AND BALANCE

The optional instrument panel and vacuum system was installed at the factory and are included in the licensed weight and balance information in Section 6 of the Pilot's Operating Handbook and FAA Approved Airplane Flight Manual.

9.9.7 DESCRIPTION AND OPERATION

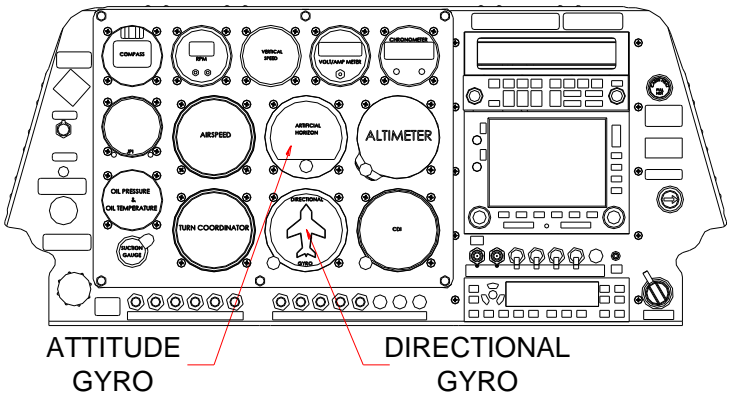


Figure 9-9-1 Optional Instrument Panel

The vacuum system operates the air driven directional gyro and the attitude gyro, when installed. Besides the instruments, the system consists of:

- Engine driven vacuum pump
- Vacuum regulator
- Vacuum gauge
- Filter
- Plumbing

The pump is of the dry type. If the pump should become obstructed, a shear drive will protect it from damage but will render the gyroscopic instruments inoperative.

The regulator is set so that the vacuum gauge reads between 4.8 and 5.2 inches of mercury. Its function is to protect the gyros.

The vacuum gauge should be monitored periodically during flight. If a decrease in pressure is noticed (relative to what the instrument normally reads), then there may be a dirty filter, dirty screens, a leak in the system or a problem with the regulator. An inoperative pump, a defective gauge, or a collapsed line could cause the gauge to read zero. Should this occur at any time, a qualified mechanic should investigate the cause to prevent further damage to the system.

INTENTIONALLY LEFT BLANK

9.10 GARMIN GNS 430 COM/NAV

9.10.1 GENERAL

This supplement must be attached to the Pilot's Operating Handbook and FAA Approved Airplane Flight Manual when the GARMIN GNS 430 is installed per the Equipment List supplied with the aircraft and listed in Section 6 of this manual. The information contained herein supplements or supersedes the basic Pilot's Operating Handbook and FAA approved Flight Manual only in those areas listed in this supplement. For limitations, procedures and performance information not contained in this supplement, consult Section 2 of this Pilot's Operating Handbook and FAA Approved Airplane Flight Manual.

This supplement has been FAA approved as a permanent part of the handbook and must remain in the handbook at all times when the GARMIN GNS 430 is installed.

9.10.1.1 DESCRIPTION

The GNS 430 System is a fully integrated, panel mounted instrument, which contains a VHF Communications Transceiver, a VOR/ILS receiver, Global Positioning System (GPS) Navigation computer and a terrain awareness system (TERRAIN Option). The system consists of a GPS antenna, GPS Receiver, VHF VOR/LOC/GS antenna, VOR/ILS receiver, VHF COMM antenna and a VHF Communications Transceiver.

The primary function of the VHF Communication portion of the equipment is to facilitate communication with Air Traffic Control. The primary function of the VOR/ILS Receiver portion of the equipment is to receive and demodulate VOR, Localizer, and Glide Slope signals.

The primary function of the GPS portion of the system is to acquire signals from the GPS system satellites, recover orbital data, make range and Doppler measurements, and process this information in real-time to obtain the user's position, velocity, and time. The primary function of the TERRAIN portion of the system is to provide terrain situational awareness.

Provided the Garmin GNS 430's GPS receiver is receiving adequate usable signals, it has been demonstrated capable of and has been shown to meet the accuracy specifications for:

- VFR/IFR enroute, terminal, and non-precision instrument approach (GPS, Loran-C, VOR, VOR-DME, TACAN, NDB, NDB-DME, and RNAV) operation within the U.S. National Airspace System in accordance with AC 20-138.
- One of the approved sensors, for a single or dual GNS 430 installation, for North Atlantic Minimum Navigation Performance Specification (MNPS) Airspace in accordance with AC 91-49 and AC 120-33.
- The system meets RNP5 airspace (BRNAV) requirements of AC 90-96 and in accordance with AC 20-138 and JAA GAI-20 ACJ 20X4, provided it is receiving usable navigation information from the GPS receiver.
- The equipment as installed has been found to comply with the requirements for GPS primary means of navigation in oceanic and remote airspace, when used in conjunction with the 400 Series Trainer Program incorporating the FDE Prediction Program. This does not constitute an operational approval.

Navigation is accomplished using the WGS-84 (NAD-83) coordinate reference datum. Navigation data is based upon use of only the Global Positioning System (GPS) operated by the United States of America.

9.10.2 LIMITATIONS

The Garmin GNS 430 Pilot's Guide, P/N 190-00140-00, Rev. A, dated October, 1998, or later appropriate revision, must be immediately available to the flight crew whenever navigation is predicated on the use of the system. In addition to the Pilot's Guide, the appropriate Pilot's Guide Addendum must also be immediately available to the flight crew if lightning detection, Weather Datalink, Traffic Advisory System (TAS), Traffic Information Service (TIS), or TERRAIN are interfaced to the system or if primary means oceanic/remote navigation is conducted.

The GNS 430 must utilize the following or later FAA approved software versions:

Function	Sub-System Version				
	Main	GPS	COM	VOR/ LOC	G/S
Initial Approval	2.00	2.00	2.00	1.25	2.00
Traffic/Weather Interface	2.08	2.00	2.00	1.25	2.00
Primary Oceanic/Remote	3.00	3.00	2.00	1.25	2.00
TIS Interface	4.00	2.00	2.00	1.25	2.00
TERRAIN Option	5.01	3.01	6.00	3.01	2.03

The main software version is displayed on the GNS 430 self test page immediately after turn-on for 5 seconds. The remaining system software versions can be verified on the AUX group sub-page 2, "SOFTWARE/DATABASE VER".

If not previously defined, the following default settings must be made in the "SETUP 1" menu of the GNS 430 prior to operation (refer to Pilot's Guide for procedure if necessary):

- **dis, spd:** nm, kt or mi, mph (sets navigation units to "nautical miles" and "knots" or "statute miles" and "mph")
- **alt, vs:** ft fpm (sets altitude units to "feet" and "feet per minute")
- **map datum:** WGS 84 (sets map datum to WGS-84, see note below)
- **posn:** deg-min (sets navigation grid units to decimal minutes)

NOTE

In some areas outside the United States, datums other than WGS-84 or NAD-83 may be used. If the GNS 430 is authorized for use by the appropriate Airworthiness Authority, the required geodetic datum must be set in the GNS 430 prior to its use for navigation.

Navigation must not be predicated upon the use of TERRAIN.

CAUTION

The Terrain display is intended to serve as a situational awareness tool only. It may not provide either the accuracy or fidelity, or both, on which to solely base decisions and plan maneuvers to avoid terrain or obstacles.

To avoid giving unwanted alerts, TERRAIN must be inhibited when landing at an airport that is not included in the airport database.

The TERRAIN databases have an area of coverage as detailed below:

- The Terrain Database has an area of coverage from North 75° Latitude to South 60° Latitude in all longitudes.
- The Airport Terrain Database has an area of coverage that includes North America, and South America.
- The Obstacle Database has an area of coverage that includes the United States.

NOTE

Pilots are NOT authorized to deviate from their current ATC clearance to comply with terrain/obstacle warnings from a TERRAIN unit except as allowed by 14 CFR Part 91.3(b). TERRAIN warnings are advisory only and are not equivalent to warnings provided by a TAWA unit.

9.10.3 EMERGENCY PROCEDURES

In an in-flight emergency, depressing and holding the Comm transfer button for 2 seconds will select the emergency frequency of 121.500 MHz into the "Active" frequency window.

CAUTION

This aircraft is not certified for IFR operations. The following procedures are included in this manual for advisory purposes only.

If GARMIN GNS 430 navigation information is not available or invalid, utilize remaining operational navigation equipment as required. If the TERRAIN option

is installed, TERRAIN will not be available. A white 'TER N/A' or red 'TER FAIL' annunciator will be displayed in the lower left corner of the GNS 430 display.

If "RAIM POSITION WARNING" message is displayed the system will flag and no longer provide GPS based navigational guidance. The crew should revert to the GNS 430 VOR/ILS receiver or an alternate means of navigation other than the GNS 430's GPS Receiver. If the TERRAIN option is installed, TERRAIN will not be available. A white 'TER N/A' annunciator will be displayed in the lower left corner of the GNS 430 display.

If "RAIM IS NOT AVAILABLE" message is displayed in the enroute, terminal, or initial approach phase of flight, continue to navigate using the GPS equipment or revert to an alternate means of navigation other than the GNS 430's GPS receiver appropriate to the route and phase of flight.

When continuing to use GPS navigation, position must be verified every 15 minutes using the GNS 430's VOR/ILS receiver or another IFR-approved navigation system.

If "RAIM IS NOT AVAILABLE" message is displayed while on the final approach segment, GPS based navigation will continue for up to five minutes with approach CDI sensitivity (0.3 nautical miles). After five minutes the system will flag and no longer provide course guidance with approach sensitivity. Missed approach course guidance may still be available with one nautical mile CDI sensitivity by executing the missed approach.

If the white "TER N/A" status annunciator is displayed by the GNS 430, the system will no longer provide TERRAIN alerting or display relative terrain elevations. The crew must maintain compliance with procedures that ensure minimum terrain separation.

If the red "TER FAIL" status annunciator is displayed by the GNS 430, the system will no longer provide TERRAIN alerting or display relative terrain elevations. The crew must maintain compliance with procedures that ensure minimum terrain separation.

If a "TERRAIN has failed" message is displayed by the GNS 430, the system will no longer provide TERRAIN alerting or display relative terrain elevations. The crew must maintain compliance with procedures that ensure minimum terrain separation.

9.10.4 NORMAL PROCEDURES

Normal operating procedures are described in the GARMIN GNS 430 Pilot's Guide, P/N 190-00140-00, Rev. A, dated October 1998, or later appropriate revision.

9.10.5 PERFORMANCE

No change.

9.10.6 WEIGHT AND BALANCE

The GARMIN 430 was installed at the factory and is included in the licensed weight and balance information in Section 6 of the Pilot's Operating Handbook and FAA Approved Airplane Flight Manual.

INTENTIONALLY LEFT BLANK

9.11 WIPAIRE 2100A AMPHIBIOUS FLOATS

9.11.1 GENERAL

This supplement must be attached to the Pilot's Operating Handbook and FAA Approved Airplane Flight Manual when the Wipaire 2100A amphibious floats are installed per the Equipment List supplied with the aircraft and listed in Section 6 of this manual. The information contained herein supplements or supersedes the Pilot's Operating Handbook and FAA Approved Flight Manual only in those areas listed in this supplement. For limitations, procedures and performance information not contained in this supplement, consult Section 2 of this Pilot's Operating Handbook and FAA Approved Airplane Flight Manual.

This supplement has been FAA approved as a permanent part of the handbook and must remain in the handbook at all times when the Wipaire 2100A amphibious floats are installed.

The Wipaire 2100A amphibious floats are constructed from aluminum. The landing gear retraction is accomplished by means of an electrically powered hydraulic pump with an emergency hand-operated back-up. An Aural Landing Gear Advisory System warns the pilot of the position of the landing gear prior to landing.

**SECTION 9.11
SUPPLEMENTS-WIPAIRE
2100A AMPHIBIOUS FLOATS**

**CUB CRAFTERS
CC18-180**

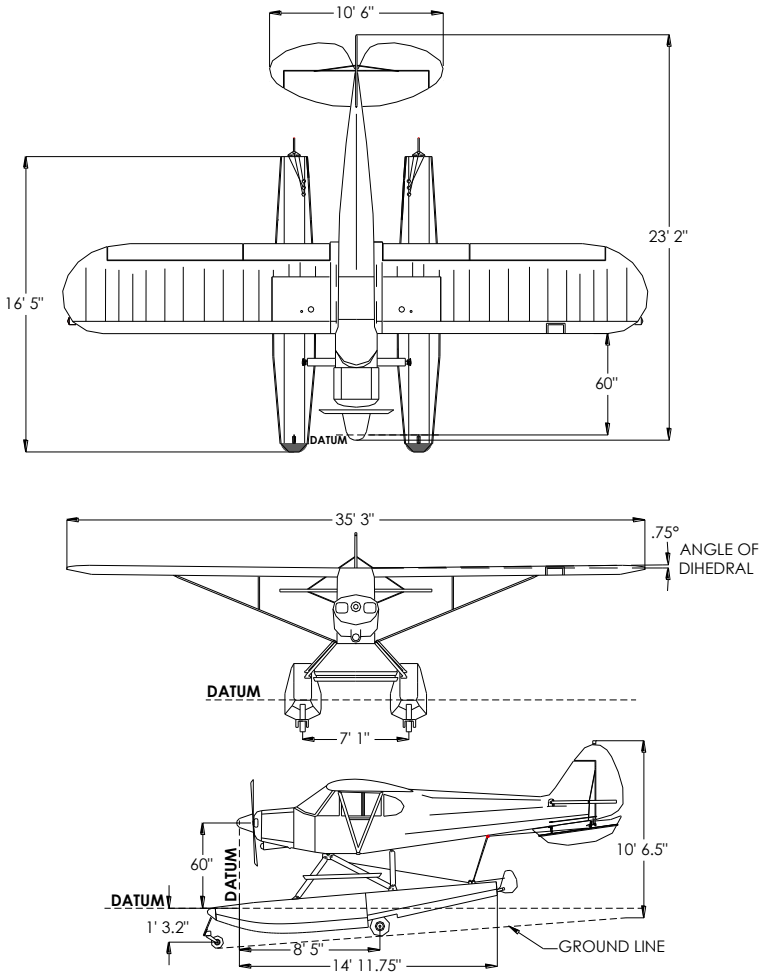
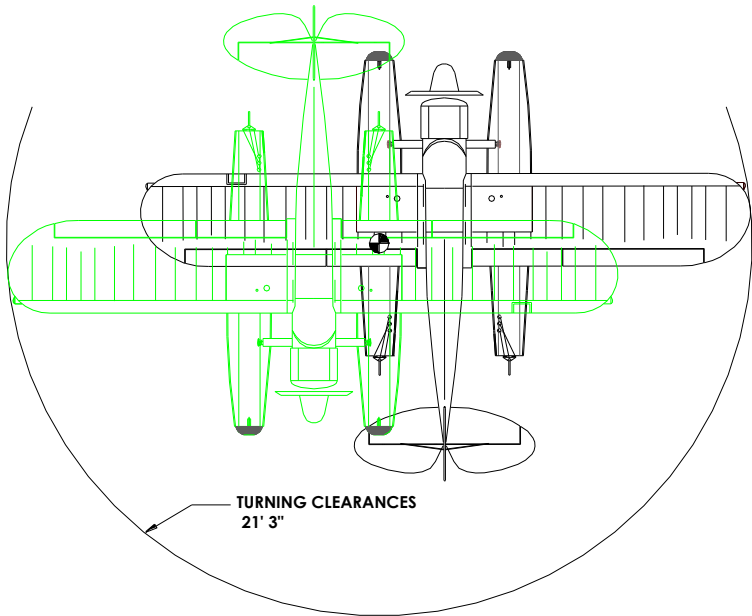


Figure 9-11-1 Three Views of the CC18-180 with Wipaire 2100A Amphibious Floats



**Figure 9-11-2 Ground Turning Radius of CC18-180
with Wipaire 2100A Amphibious Floats**

9.11.2 LIMITATIONS

9.11.2.1 GENERAL

This section provides the FAA Approved operating limitations, instrument markings, color-coding and basic placards for operation that are specific to the Cub Crafters CC18-180 aircraft equipped with Wipaire 2100A amphibious floats.

Please refer to Section 2 of this manual for the complete list of FAA Approved operating limitations, instrument markings, color-coding and basic placards for operation that are common to the landplane and the version equipped with Wipaire 2100A amphibious floats.

9.11.2.2 AIRSPEED LIMITATIONS

SPEED	IAS	
	MPH	KNOTS
Maximum Speed for landing gear operation V_{LO}	133	116
Maximum Speed with landing gear down	133	116

Do not exceed this speed with the landing gear extended.

9.11.2.3 CENTER OF GRAVITY

Forward at 2300 lbs. 75.0 in. aft of Datum
at 1600 lbs. or less..... 70.5 in. aft of Datum
(Straight line variation between points given)
Aft (at all weights)..... 79.0 in. aft of Datum

The datum is 60 in. forward of wing leading edge.

9.11.2.4 AMPHIBIOUS OPERATION

Landing on water is PROHIBITED unless all four landing gear are fully retracted.

9.11.2.5 PLACARDS

Locate in clear view of pilot:



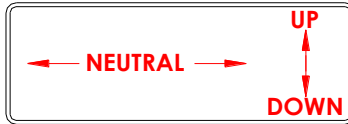
Locate near water rudder retraction handle stowage hook:



Locate in clear view of pilot:



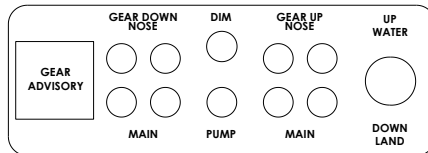
Locate at the emergency gear hand pump:



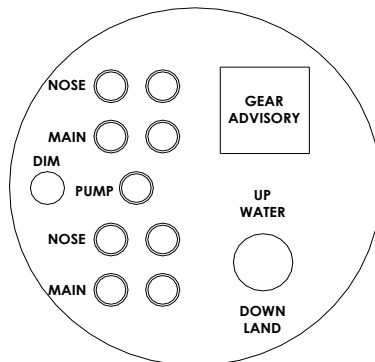
CAUTION
EXCESSIVE MECHANICAL
FORCE AT ENDS OF STROKE
MAY CAUSE PUMP DAMAGE

EMERGENCY HANDPUMP
PULL GEAR MOTOR CIRCUIT BREAKER
SELECT DESIRED GEAR POSITION
PUMP GEAR TO DESIRED POSITION

For Square Landing Gear Control Panel [All serial numbers]:



For Round Landing Gear Control Panel [Serial numbers 18-0002 through 18-0054]:



**SECTION 9.11
SUPPLEMENTS-WIPAIRE
2100A AMPHIBIOUS FLOATS**

**CUB CRAFTERS
CC18-180**

In view of the pilot:

REFER TO SECTION 9.11 OF THE AFM FOR OPERATION
WITH WIPAIRE 2100A AMPHIBIOUS FLOATS

Next to the water rudder retraction handle:

WATER RUDDER CONTROL

On inside of accessory compartment:

**NO STOWAGE ALLOWED
WHEN HYDRAULIC PUMP IS INSTALLED**

Inside float hatches:

**MAX. CAPACITY 50 lb
ARM 55.0 IN**

Locate on both sides of Ventral Fin:

NO PUSH

9.11.3 EMERGENCY PROCEDURES

9.11.3.1 GENERAL

This section provides the procedures that Cub Crafters recommends should be followed when encountering an emergency or a critical situation as related specifically to operations when the Wipaïre 2100A amphibious floats are installed. For all other emergency procedures, refer to Section 3 of this manual.

This section is divided into two parts. The first contains emergency procedure checklists. The second part amplifies the items listed in the checklists and includes information that is not readily adaptable to a checklist format or which the pilot could not be expected to refer to in an emergency situation. This information should be reviewed regularly.

Pilots must familiarize themselves with the procedures in this section and must be prepared to take appropriate action should an emergency arise.

It is stressed that the procedures outlined in this section are recommendations only. They are not a substitute for sound judgment and common sense and may have to be adjusted depending on the circumstances prevailing at the time of the emergency. It is important that the pilot be thoroughly familiar with the aircraft. He/She must review and practice as many of these procedures as are safe to perform as part of his/her training. Above all, in any emergency situation, **MAINTAIN CONTROL OF THE AIRCRAFT.**

**9.11.3.2 AIRSPEEDS FOR EMERGENCY OPERATIONS
IAS**

AT MAXIMUM WEIGHT OF 2300 LB	MPH	KNOTS
STALL SPEED		
Flaps Up (V_{S1})	53	46
Flaps Down (50°) (V_{S0})	48	42
BEST GLIDE (V_G)		
Flaps Up	68	59

Configuration: Landing gear retracted, flaps up

9.11.3.3 EMERGENCY CHECKLIST

9.11.3.3.1 Emergency Landing on Water without Engine Power

	IAS	
	MPH	KNOTS
• Airspeed (flaps up)	68	59
• Seat belts.....	Tight and secure	
• Landing gear.....	Up (four blue lights)	

When landing area assured:

- Flaps..... As required
- Door..... Open
- ELT..... Activate
- Touchdown..... Slightly tail low
- Control stick..... Hold full aft

When aircraft comes to a stop:

- Magnetos..... Off
- Master switch..... Off
- Fuel selector..... Off

If time permits, check GPS or charts for airports in the immediate vicinity. If possible, notify your difficulty and intentions by radio and/or squawk 7700.

**9.11.3.3.2 Emergency Landing on Land without
Engine Power**

	IAS	
	MPH	KNOTS
Airspeed (flaps up) V_G	68	59
Seat belts	Tight and secure	
Landing gear	Up (four blue lights)	

When landing area assured:

- Landing gearUp for rough terrain
Down for smooth terrain
- Flaps As required
- Door Open
- ELT..... Activate
- Touchdown..... Level attitude
- Control stick Hold full aft
- Brakes As required

When aircraft comes to a stop:

- Magnetos Off
- Master switch Off
- Fuel selector..... Off

If time permits, check GPS or charts for airports in the immediate vicinity. If possible, notify your difficulty and intentions by radio and/or squawk 7700.

9.11.3.3.3 Landing Gear Fails to Retract or Extend

- Master switch..... Check on
- Landing gear switch..... Check for desired position
- Landing gear circuit breaker Check in
- Landing gear lights Blue for gear Up
Green for gear Down
- Landing gear position Check visually

If landing gear is still in the improper position:

- Airspeed Reduce to minimize loads on gear
- Landing gear switch..... Recycle
- Landing gear motor Check red light on

If landing gear motor is inoperative or landing gear not in the desired position:

- Landing gear circuit breaker Pull
- Landing gear switch..... Desired position
(Up for water, down for land)
- Landing gear emergency valve..... Select position
(Up for water, down for land)
(At night, turn on E. Pump Light)
- Emergency hand pump Pump until four lights
illuminate in desired gear position

If lights do not illuminate, pump until noticeable resistance
(Up to 120 cycles)

- Landing gear position Confirm visually

If landing gear fails to retract or extend manually:

**WARNING
DO NOT ATTEMPT TO LAND ON WATER UNLESS
ALL FOUR WHEELS ARE IN THE RETRACTED
POSITION**

If the landing gear is fully up and it is practical to land on water, land on water.

If the landing must be done on land, plan for wheels up landing.

9.11.3.4 AMPLIFIED EMERGENCY PROCEDURES

9.11.3.4.1 Total Loss of Engine Power in Flight

The CC18-180 equipped with Wipaïre 2100A amphibious floats will glide 1.1 nautical miles for every 1000 feet of altitude loss. The rate of descent will be approximately 890 feet per minute. Most GPS have a "Direct to" function that shows the closest airports. Use charts to assess the topography of airports in the immediate vicinity.

9.11.3.4.2 Emergency Landing on Water without Engine Power

Over and above the procedures described in Section 3, special attention must be paid to the fact that the landing gear must be retracted to land on water. Otherwise, there is a strong possibility that the aircraft will turn over.

9.11.3.4.3 Emergency Landing on Land without Engine Power

When having to make an emergency landing on land on a CC18-180 equipped with amphibious floats, the position of the landing gear will depend on the conditions of the terrain. The pilot will have to use his/her best judgment in each case.

9.11.4 NORMAL PROCEDURES

9.11.4.1 INTRODUCTION

This section describes the procedures that Cub Crafters recommends for the pilot to follow during normal operations of the CC18-180 on Wipaïre 2100A amphibious floats. It is divided into two parts. The first has abbreviated checklists; these are in a format suitable for reference in the cockpit. The second part amplifies the information given in the checklists. It provides the pilot with detailed descriptions that will help him/her understand the procedures and techniques. This section

contains complete checklists so that the pilot can carry out these activities out without having to turn back and forth in this manual.

9.11.4.2 AIRSPEEDS FOR NORMAL OPERATIONS

The speeds in this section are based on a maximum weight of 2300 lbs., under standard conditions, at sea level.

SPEED	IAS	
	MPH	KNOTS
Never Exceed Speed (V_{NE})	152	132
Operating Maneuvering Speed (V_O)	102	88
Maximum Flap Speed (V_{FE}) Flaps 50°	89	77
Best rate of climb speed (V_Y)	74	64
Best angle of climb speed (V_X)	63	55
Maximum demonstrated crosswind velocity.....	11 kts	

9.11.4.3 MAXIMUM WAVE HEIGHT

Maximum demonstrated wave height..... 1 ft

9.11.4.4 NORMAL PROCEDURES CHECKLIST

For ease of operation, this supplement will provide the complete checklist.

9.11.4.4.1 Cockpit Preflight

- Flight controls Free and correct operation
- Trim Check operation and set for takeoff
- Fuel selector Both
- Flaps..... Proper operation
- Fuel gauges..... Sufficient qty for intended flight
- Mixture..... Idle cut-off
- Carburetor heat Cold
- Magnetos..... Off
- Electrical switches Off
- Landing gear switch..... Proper position
Down for land, Up for water

-
- Water rudders Check operation and set
-Up for land, Down for water. Ensure handle is stowed
 - Master switch On
 - Landing gear lights..... Proper indication
 - Four **GREEN** for land, Four **BLUE** for water
 - Landing gear position annunciator light Press for
4 seconds and release
Amber annunciator flashes
Aural announcements
“GEAR IS UP FOR WATER LANDING”
“GEAR IS DOWN FOR RUNWAY LANDING”
 - Navigation/strobe lights..... Check operation
 - Landing lights..... Check operation
 - Stall warning horn Check operation
 - Master switch Off
 - Circuit breakers Check in
 - Windows..... Clear
 - Documentation Onboard
- If passenger seat unoccupied:
- Passenger seat harness Secure

9.11.4.4.2 Preflight Right Fuselage, Wing, and Float

- Right Fuselage Check
- Baggage Door..... Closed
- Accessory Door..... Open
- Power Pack Reservoir Level Above ¼ full
- Accessory Door..... Closed and latched
- Fuel Drain..... Sump
- Flap Surface..... Check condition
- Flap Hinges..... Check
- Aileron Surface..... Check condition
- Aileron Hinges..... Check
- Wing Tip and Light Check
- Stall Warning Vane Check condition
- Vortex Generators..... Check
- Tie Down Remove

**SECTION 9.11
SUPPLEMENTS-WIPAIRE
2100A AMPHIBIOUS FLOATS**

**CUB CRAFTERS
CC18-180**

- Fuel Vent Check
- Fuel Tank..... Check supply and cap for security
- Water Rudders and Cables Check
- Float..... Check for damage and water accumulation
(use bilge pump as necessary)

NOTE

Remove rubber plugs which serve as stoppers on the standpipe in each float compartment and pump out any accumulation of water. Reinstall rubber plugs with enough pressure for a snug fit.

- Bilge rubber plugs..... Secure
- Oar..... Check stowed and secure
- Float hatchesCargo secure and hatches latched
- Main landing gear brakes and lines Check
- Main landing gear shock absorber and tire Check
- Chocks..... Removed
- Nose gear and springs Check

9.11.4.4.3 Preflight Nose Section

- Right static port..... Clear
- Right cowling Open
- Oil quantity..... Check and cap secure
(Min recommended 6 Qt or 5.7 liters)
- Engine condition Check
- Right cowling Close & Secure
- Propeller and spinner Check
- Air inlets Check
- Left cowling..... Open
- Engine condition Check
- Left cowling..... Close
- Fuel strainer..... Sump
- Left static port Clear

9.11.4.4.4 Preflight Left Fuselage, Wing, and Float

- Nose gear and springs Check
- Chocks Removed
- Main landing gear shock absorber and tire Check
- Main landing gear brakes and lines Check
- Float hatches..... Cargo secure and hatches latched
- Float Check for damage and water accumulation
(use bilge pump as necessary)

NOTE

Remove rubber plugs which serve as stoppers on the standpipe in each float compartment and pump out any accumulation of water. Reinstall rubber plugs with enough pressure for a snug fit.

- Bilge rubber plugs Secure
- Fuel tank Check supply and cap for security
- Fuel vent Check
- Tie down..... Remove
- Landing light..... Check condition
- Pitot tube Check condition
- Wing tip and light..... Check condition
- Vortex generators..... Check
- Aileron hinges Check
- Aileron surface Check condition
- Flap hinges..... Check
- Flap surface Check condition
- Fuel Drain..... Sump
- Water rudders and cables Check
- Left fuselage..... Check

9.11.4.4.5 Empennage

- Bracing wires..... Check for tension
- Hinges Check
- Surfaces Check
- Ventral fin Check

- Tie down Remove

9.11.4.4.6 Preflight General

Check that all wings and other external surfaces are free from frost, ice or snow.

9.11.4.4.7 Startup and Taxi

- Preflight inspection Complete
- Pilot seat Adjusted
- Seat belts Fastened
- Passenger briefing Complete
- Door & Windows Closed
- Fuel selector Both
- Avionics master switch Off
- Water rudders Down for water, Up for land
- Propeller area Clear

9.11.4.4.8 Starting Engine

- Battery master switch On
- Beacon On
- Magneto switches Both on
- Mixture Full rich
- Primer Apply*
- Throttle Open 1/2 inch
- Starter Engage

After engine has started:

- Oil pressure Check
- Throttle Set 1000 RPM
- Lights As required
- Avionics master switch On

*Normal procedure three times. If engine is hot, omit this step.

9.11.4.4.9 Starting Engine When Flooded

- Magneto switches Both on
- Mixture Idle cut-off
- Throttle Full open
- Starter Engage

When engine starts:

- Mixture Rich
- Throttle Retard to 1000 RPM
- Oil pressure Check
- Lights As required
- Avionics master switch On

9.11.4.4.10 Warm up

- Throttle 1000 to 1200 RPM

9.11.4.4.11 Taxiing

- Parking brakes (on land) Release
- Taxi area Clear
- Throttle Apply slowly
- Brakes (on land) Check
- Steering (on land) Use differential braking
- Pitot heat (if required) On

9.11.4.4.12 Before Takeoff on Land

- Parking brake Set
- Throttle 1700 RPM*
- Magnetos Check
Drop not to exceed 175 RPM or 50 RPM differential
between magnetos and no engine roughness
- Carburetor heat Hot, note RPM drop, Cold
- Engine instruments Check
- Ammeter Check
- Throttle Check idle
- Throttle 1000 RPM
- Flight instruments Check
- Fuel selector Both and sufficient qty for flight

- Engine gauges..... Check
 - Mixture..... Set*
 - Magnetos..... Both
 - Carburetor heat Off
 - Primer In & Locked
 - Trim Set
 - Flaps..... First notch (takeoff 22°)
 - Controls Free and Correct
 - Door & Windows..... Closed
 - Strobes and lights..... As required
 - Transponder and other avionics On
 - Seat belts..... Check fastened
 - Parking brakes..... Release
- * When operating at high altitudes and/or temperatures, it may be necessary to lean the mixture for peak RPM.

9.11.4.4.13 Before Takeoff on Water

- Flight instruments Check
- Magnetos..... Both
- Carburetor heat Off (cold)
- Trim Set
- Flaps..... First notch (22°)
- Controls Free and correct movement
- Door & Windows..... Closed
- Strobes and lights..... As required
- Seat belts..... Check fastened
- Throttle 1700 RPM*
- Mixture..... Set*
- Magnetos..... Check
Drop not to exceed 175 RPM or 50 RPM differential
between magnetos and no engine roughness.
- Carburetor heat Hot, note RPM drop, Cold
- Primer In & Locked
- Engine instruments..... Check
- Ammeter Check

9.11.4.4.17 Cruise

- Power Adjust
- Mixture Adjust
- Carburetor heat As required

9.11.4.4.18 Descent

- Power Adjust
- Mixture Full rich below 3000'
- Carburetor heat As required

9.11.4.4.19 Approach

- Fuel Selector Both
- Seat belts Fastened
- Mixture Set
- Flaps Set

	AIRSPEED (IAS)	MPH	KNOTS
Maximum speed first notch flaps (22°)	98	85	
Maximum speed full flaps (50°)	89	77	

- Trim As required
- Speed As required

(1.3 times full flaps stall speed at gross weight is 63 MPH or 55 KTS IAS)

9.11.4.4.20 Landing on Land

- Landing gear Down

	AIRSPEED (IAS)	MPH	KNOTS
V_{LO}		133	116

- Landing gear lights Four **GREEN** for land
- Landing gear hydraulic pump light Verify off once gear is locked in desired position
- Landing gear Check visually for correct position

9.11.4.4.21 Landing on Water

- Landing gear Up
- Landing gear lights Four **BLUE** for water

- Landing gear hydraulic pump Off
- Landing gear Check visually for correct position

WARNING
**DO NOT ATTEMPT TO LAND ON WATER UNLESS
ALL FOUR WHEELS ARE IN THE RETRACTED
POSITION**

- Control stick Hold full aft
as aircraft decelerates to taxi speed

NOTE
At a forward loading and if the control stick is not held back, the aircraft may pitch down as it comes off the step.

9.11.4.4.22 Cross Wind Landing

- Fuel selector Both
- Seat belts Fastened
- Mixture Set
- Flaps Set below white arc

	AIRSPEED (IAS)	MPH	KNOTS
Maximum speed first notch flaps (22°)		98	85
Maximum speed full flaps (50°)		89	77

- Landing gear Up for water, Down for Land
- Landing gear lights Four **BLUE** for water
Four **GREEN** for land
- Trim As required
- Speed As required
(A higher speed than normal is recommended)
- Ailerons-rudder On short final
- Use ailerons to keep upwind wing low
- Rudder to hold runway alignment
- Touchdown Do not touch down in a slip
- Landing roll Use ailerons to keep upwind wing
down, rudder and brakes to maintain directional
control as appropriate

9.11.4.4.23 Go-around

- Throttle Full power
 - Landing gear..... Retract
- | AIRSPEED (IAS) | MPH | KNOTS |
|-----------------------|------------|----------------|
| • Airspeed Above | 54 | 47 |
| • Flaps..... | | Retract slowly |
| • Trim | | As required |

9.11.4.4.24 Stopping Engine

- Parking brakes (on wheels) Set
- Flaps..... Retract
- Electrical equipment Off
- Avionics master switch Off
- Throttle Idle
- Mixture..... Idle cut off
- Magnetos..... Off
- Master switch..... Off

9.11.4.5 AMPLIFIED PROCEDURES

This section will amplify specific procedures that relate to the operation of the aircraft equipped with Wipaïre 2100A amphibious floats. For amplified procedures that are common to the landplane and the floatplane, please refer to Section 4 of this manual.

9.11.4.5.1 Preflight

Ensure that the landing gear selector is in the correct position and after turning on the aircraft's electrical power, make certain that the landing gear indication is correct. Check the operation, retraction and extension of the water rudders.

To determine the fuel quantity on the ground, use the fuel quantity indication for level flight. Fuel indications in the water will vary depending on the angle at which the aircraft is floating.

The bilge pump is located in the right float hatch. To empty the floats of water, remove the rubber plugs, and pump out any accumulated water. Once the process is complete, make sure that the rubber plugs are fitted tightly.

9.11.4.5.2 Before Takeoff on Water

It is very important to ascertain that the landing gear is retracted, prior to initiating a takeoff on water.

9.11.4.5.3 Landing

Emphasis is made on the fact that the landing gear must be retracted for landing on water and extended for landing on land.

<p>WARNING DO NOT ATTEMPT TO LAND ON WATER UNLESS ALL FOUR WHEELS ARE IN THE RETRACTED POSITION</p>

9.11.5 PERFORMANCE

9.11.5.1 INTRODUCTION

The purpose of this section is to provide information that will assist the pilot of a CC18-180 equipped with Wipaïre 2100A amphibious floats with planning a flight in detail with reasonable accuracy.

All data has been corrected to I.C.A.O. standard day conditions. Where appropriate, the data has been expanded analytically for variations in weight, altitude, temperature, etc.

The data has been derived from actual flight tests, taking into account the proficiency of an average pilot. The pilot must use sound judgment when assessing the effect of conditions not found in the charts, such as soft runways and winds aloft. The parameters will be affected by the performance of the engine. Therefore, the pilot must be thoroughly familiar with its operation, including the procedures for adjusting the mixture control.

Data should not be extrapolated beyond the limits shown on the charts.

All information is presented in the units used on the aircraft's instrumentation. Conversion Charts are available in Section 5.3.

- Airspeeds in statute miles per hour
- Weights in pounds
- Altitudes in feet
- Temperatures in degrees Celsius
- Wind speed in nautical miles per hour

PERFORMANCE CHARTS

Figure 9-11-3 Stall Speed versus Angle of Bank at 2300 lbs. with Wipaire 2100A Amphibious Floats..9-11-26

Figure 9-11-4 Takeoff ground distance with Wipaire 2100A Amphibious Floats- Land9-11-27

Figure 9-11-5 Takeoff distance to 50' obstacle at with Wipaire 2100A Amphibious Floats- Land.....9-11-29

Figure 9-11-6 Takeoff ground distance with Wipaire 2100A Amphibious Floats- Water9-11-31

Figure 9-11-7 Takeoff distance to 50' obstacle at with Wipaire 2100A Amphibious Floats- Water9-11-33

Figure 9-11-8 Maximum Rate and Climb Gradient of Climb at 2300 lbs. with Wipaire 2100A Amphibious Floats9-11-36

Figure 9-11-9 Landing distance from 50' obstacle at 2300 lbs. with Wipaire 2100A Amphibious Floats- Land....9-11-37

Figure 9-11-10 Landing ground distance with Wipaire 2100A Amphibious Floats- Land9-11-39

Figure 9-11-11 Landing distance from 50' obstacle at 2300 lbs. with Wipaire 2100A Amphibious Floats- Water.....9-11-41

Figure 9-11-12 Landing ground distance with Wipaire 2100A Amphibious Floats- Water9-11-43

Figure-9-11-13 Bailed Landing Climb Gradient with Wipaire 2100A Amphibious Floats9-11-45

Figure 9-11-14 Glide Performance with Wipaire 2100A Amphibious Floats.....9-11-45

9.11.5.2 STALL SPEED

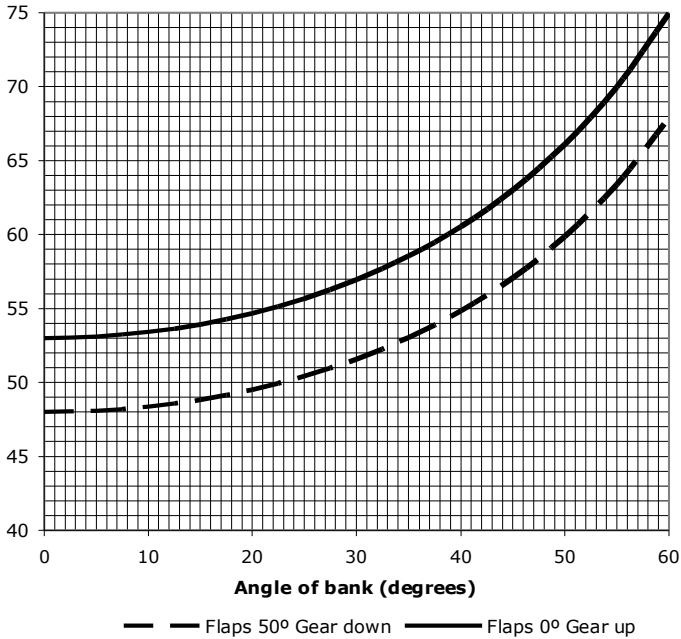


Figure 9-11-3 Stall Speed versus Angle of Bank at 2300 lbs. with Wipaire 2100A Amphibious Floats

9.11.5.2 TAKEOFF

9.11.5.2.1 NORMAL TAKEOFF: LAND

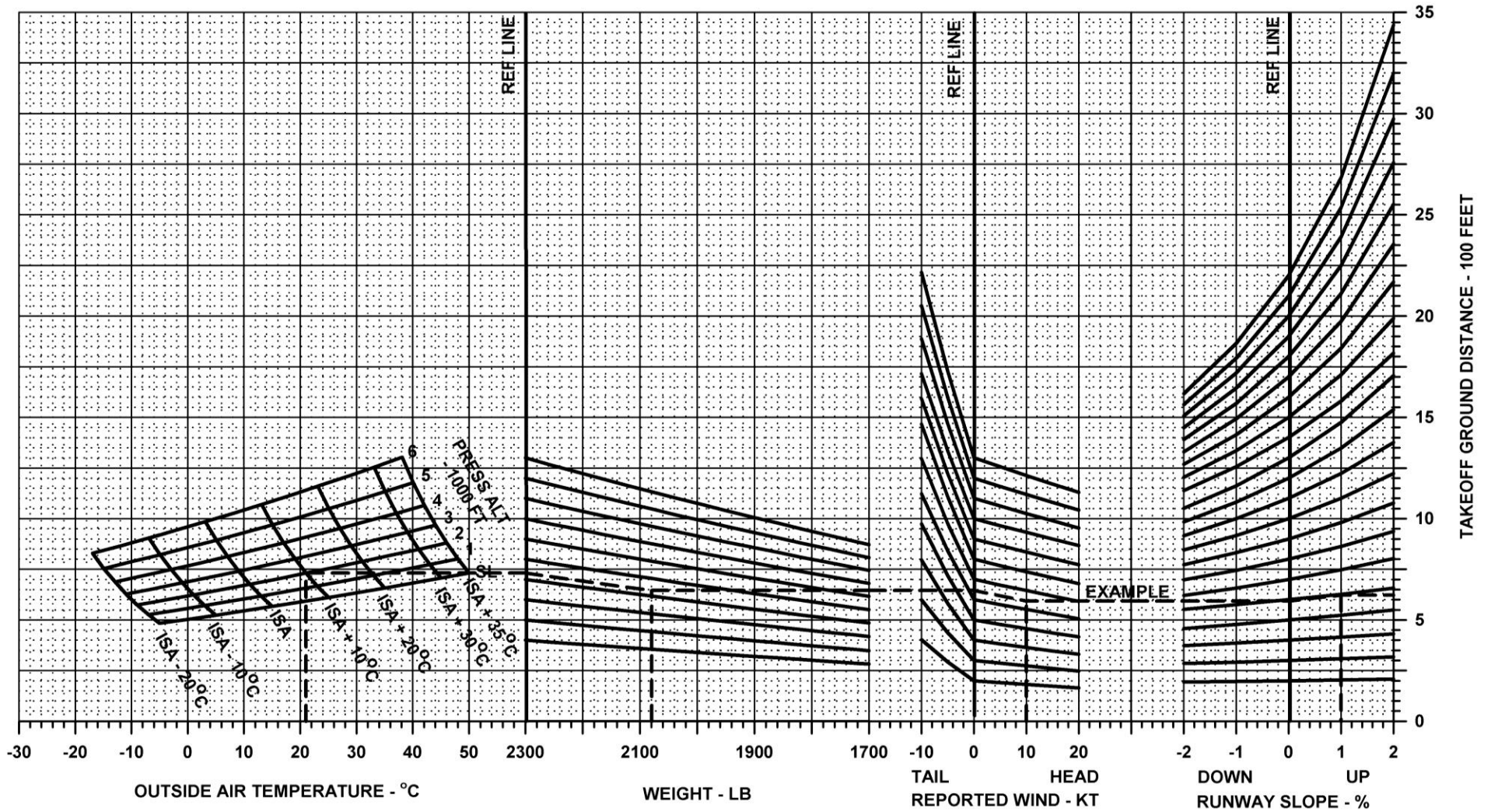


Figure 9-11-4 Takeoff Ground Distance with Wipaire 2100A Amphibious Floats - Land

INTENTIONALLY LEFT BLANK

9.11.5.2.2 TAKEOFF WITH 50' OBSTACLE: LAND

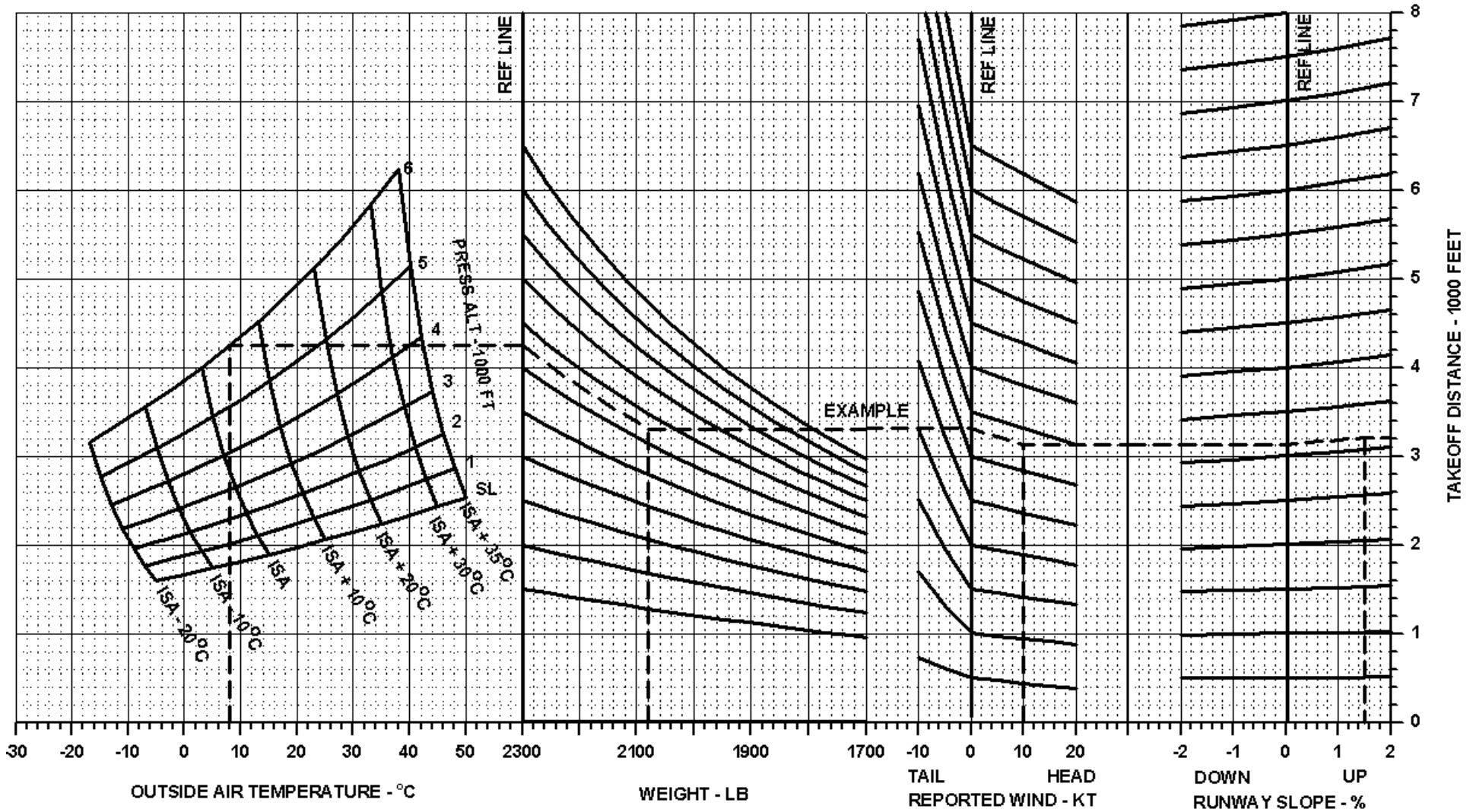


Figure 9-11-5 Takeoff Distance to 50' Obstacle with Wipaire 2100A Amphibious Floats- Land

INTENTIONALLY LEFT BLANK

9.11.5.2.3 NORMAL TAKEOFF: WATER

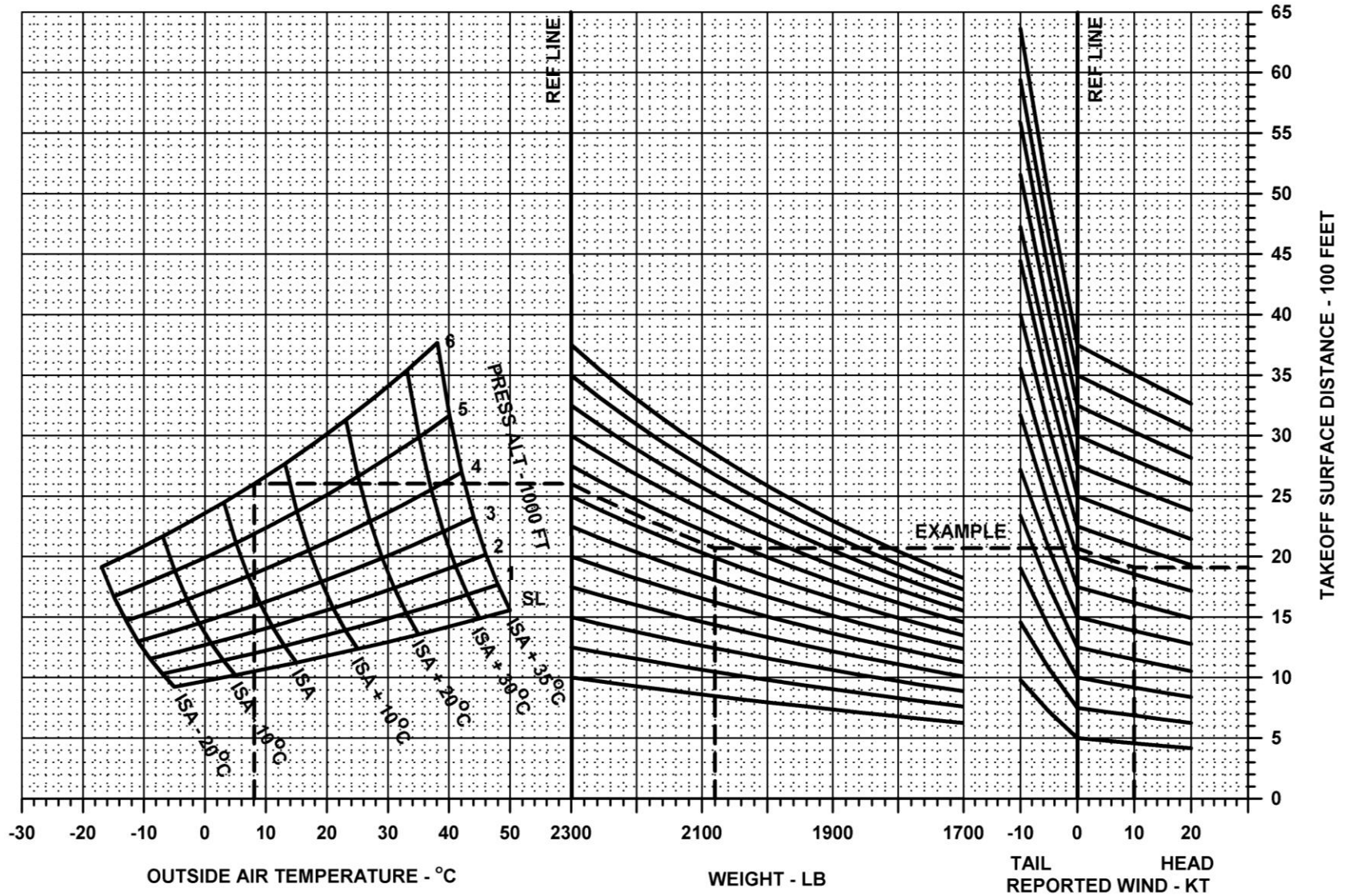


Figure 9-11-6 Takeoff Ground Distance with Wipaire 2100A Amphibious Floats - Water

INTENTIONALLY LEFT BLANK

9.11.5.2.4 TAKEOFF WITH 50' OBSTACLE: WATER

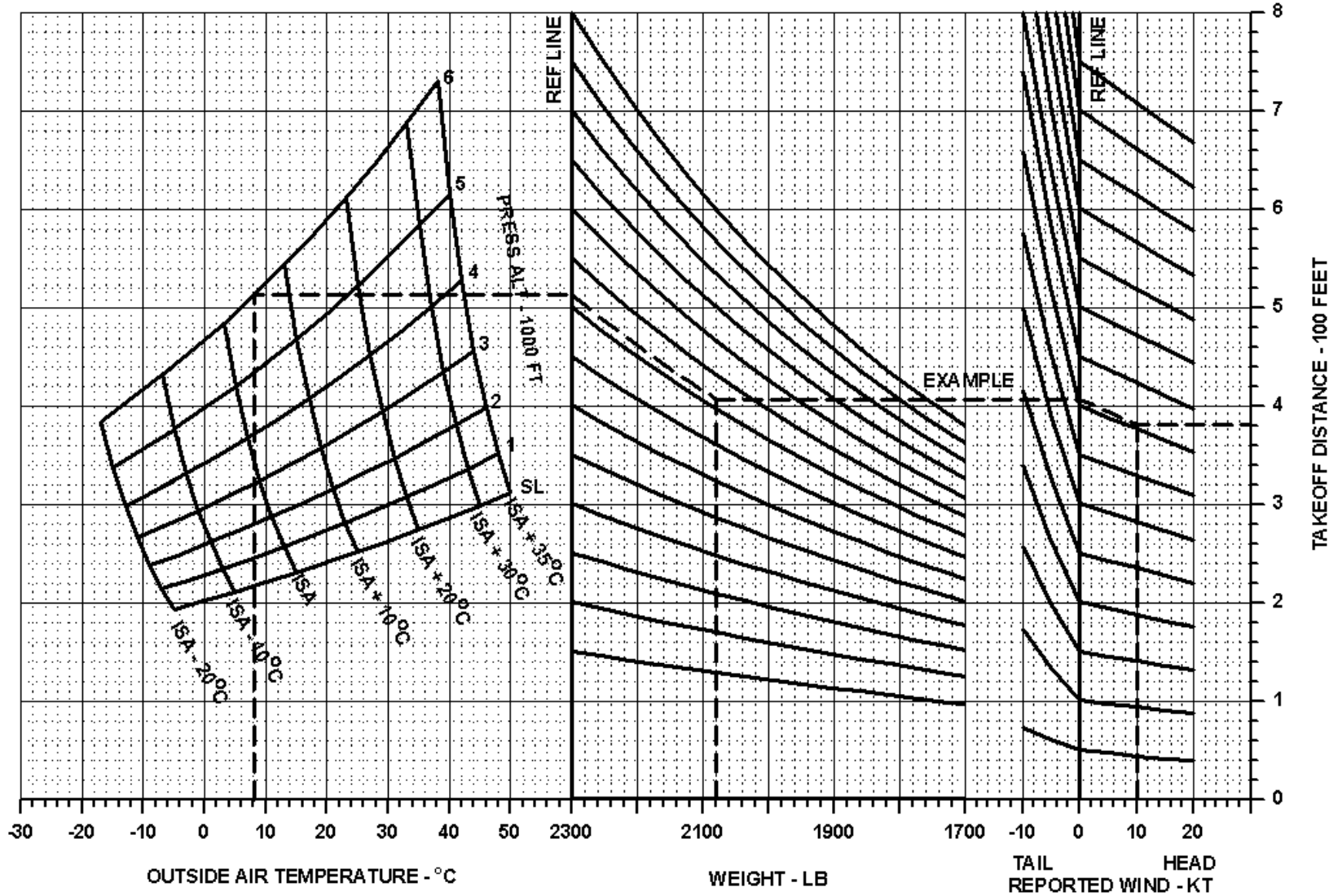


Figure 9-11-7 Takeoff Distance to 50' Obstacle with Wipaire 2100A Amphibious Floats- Water

INTENTIONALLY LEFT BLANK

9.11.5.4 CLIMB RATE AND GRADIENT

Pressure altitude (ft)	Int'l Standard Atmosphere	Airspeed (IAS)		OAT		Climb gradient %	Rate of climb (fpm)	
		MPH	KTS	°F	°C			
0	ISA-59°F (0° F)	75	65	0	-18	12%	764	
2000		73	63	-7	-22	10%	665	
4000		72	63	-14	-26	9%	566	
6000		71	62	-21	-29	7%	463	
8000		ISA-32.8 (-17.8° C)	70	61	-29	-34	6%	366
10000			69	60	-36	-38	4%	266
12000			68	59	-43	-42	3%	165
0	ISA-27°F (32° F)	75	65	32	0	11%	713	
2000		73	63	25	-4	10%	620	
4000		72	63	18	-8	8%	527	
6000		71	62	11	-12	7%	430	
8000		ISA-15°C (0° C)	70	61	3	-16	6%	340
6000			69	60	-4	-20	4%	246
12000			68	59	-11	-24	3%	152
0	ISA (59° F)	75	65	59	15	10%	660	
2000		73	63	52	11	9%	572	
4000		72	63	45	7	8%	484	
6000		71	62	38	3	6%	396	
8000		ISA (15° C)	70	61	30	-1	5%	308
10000			69	60	23	-5	4%	220
12000			68	59	16	-9	2%	132
0			ISA+16° F (75° F)	75	65	75	24	10%
2000	73	63		68	20	9%	568	
4000	72	63		61	16	8%	482	
6000	71	62		54	12	6%	393	
8000	ISA+8.9° C (23.9° C)	70		61	46	8	5%	310
10000		69		60	39	4	4%	224
12000		68		59	32	0	2%	138

**SECTION 9.11
SUPPLEMENTS-WIPAIRE
2100A AMPHIBIOUS FLOATS**

**CUB CRAFTERS
CC18-180**

Pressure altitude (ft)	Int'l Standard Atmosphere	Airspeed (IAS)		OAT		Climb gradient %	Rate of climb (fpm)
		MPH	KTS	°F	°C		
0	ISA+41° F (100° F) ISA+22.8° C (37.8° C)	75	65	100	38	10%	625
2000		73	63	93	34	8%	542
4000		72	63	86	30	7%	459
6000		71	62	79	26	6%	375
8000		70	61	71	22	5%	295
10000		69	60	64	18	4%	213
12000		68	59	57	14	2%	131

Figure 9-11-8 Maximum Rate and Climb Gradient of Climb at 2300 lbs. with Wipaïre 2100A Amphibious Floats

NOTE

Mixture leaned for peak EGT
Landing gear up

9.11.5.4 LANDING

9.11.5.4.1 NORMAL LANDING: LAND

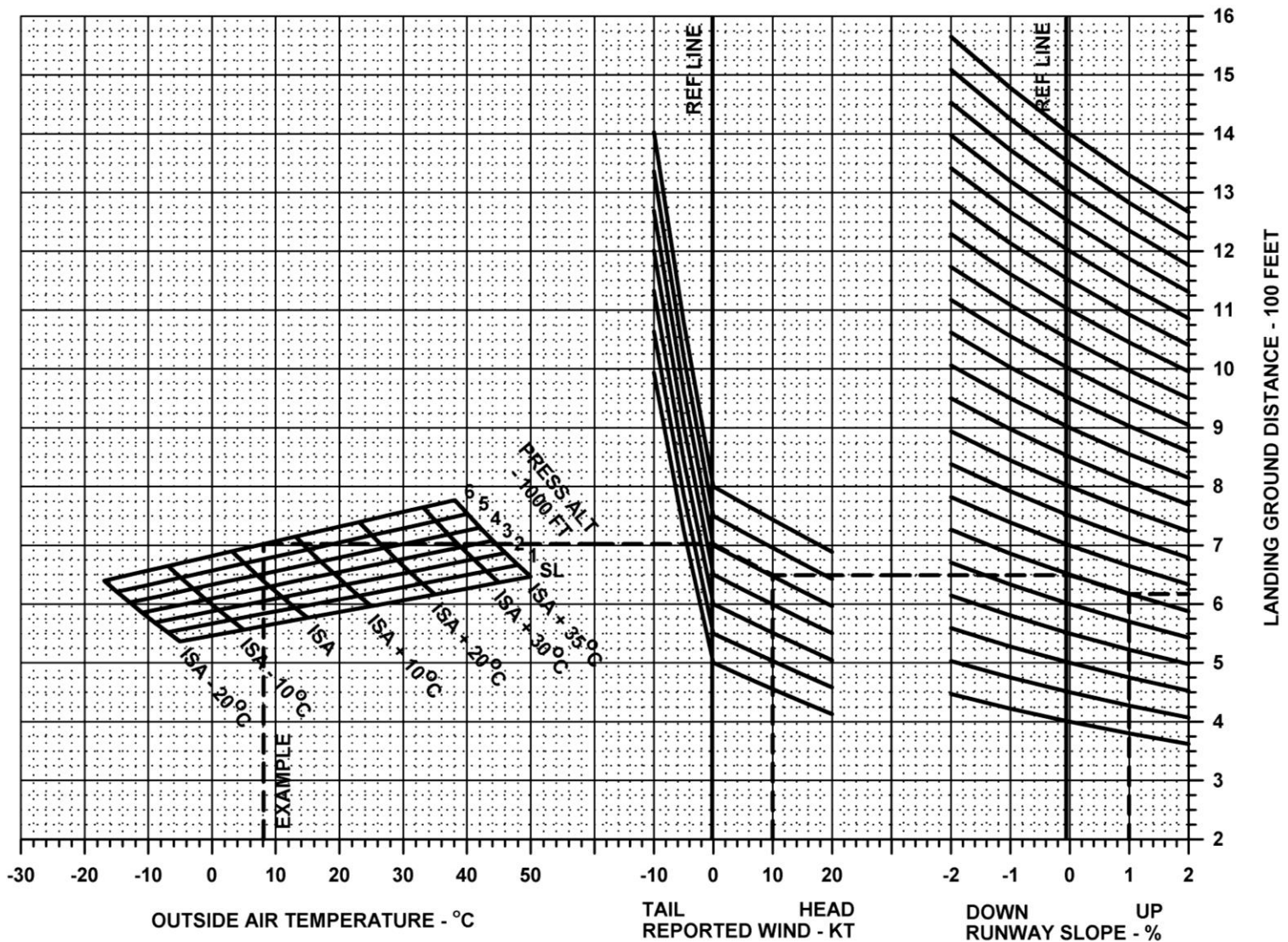


Figure 9-11-10 Landing Ground Distance with Wipaïre 2100A Amphibious Floats - Land

INTENTIONALLY LEFT BLANK

9.11.5.4.2 LANDING WITH 50' OBSTACLE: LAND

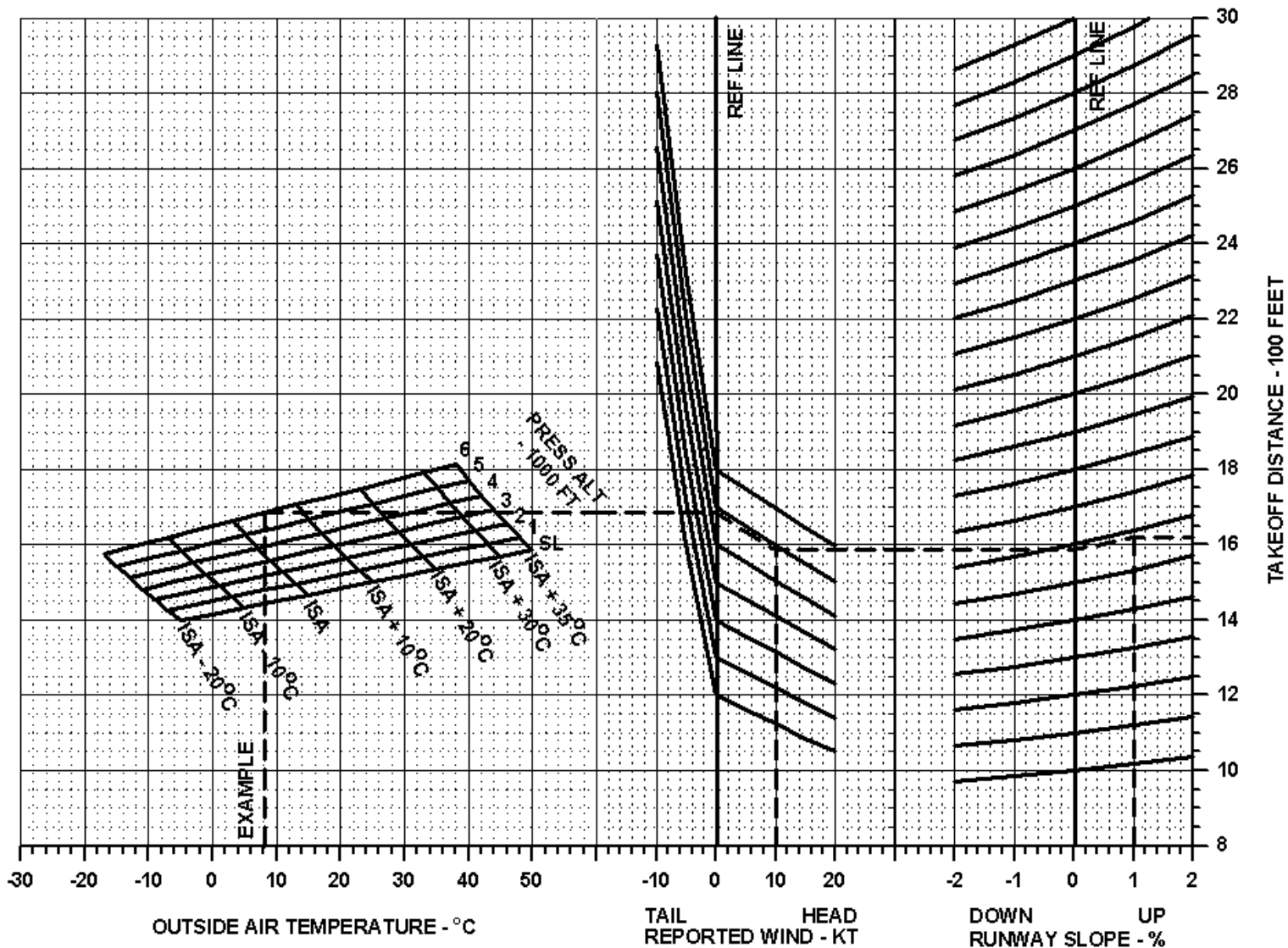


Figure 9-11-9 Landing Distance from 50' Obstacle at 2300 lb. with Wipaire 2100A Amphibious Floats - Land

INTENTIONALLY LEFT BLANK

9.11.5.4.3 NORMAL LANDING: WATER

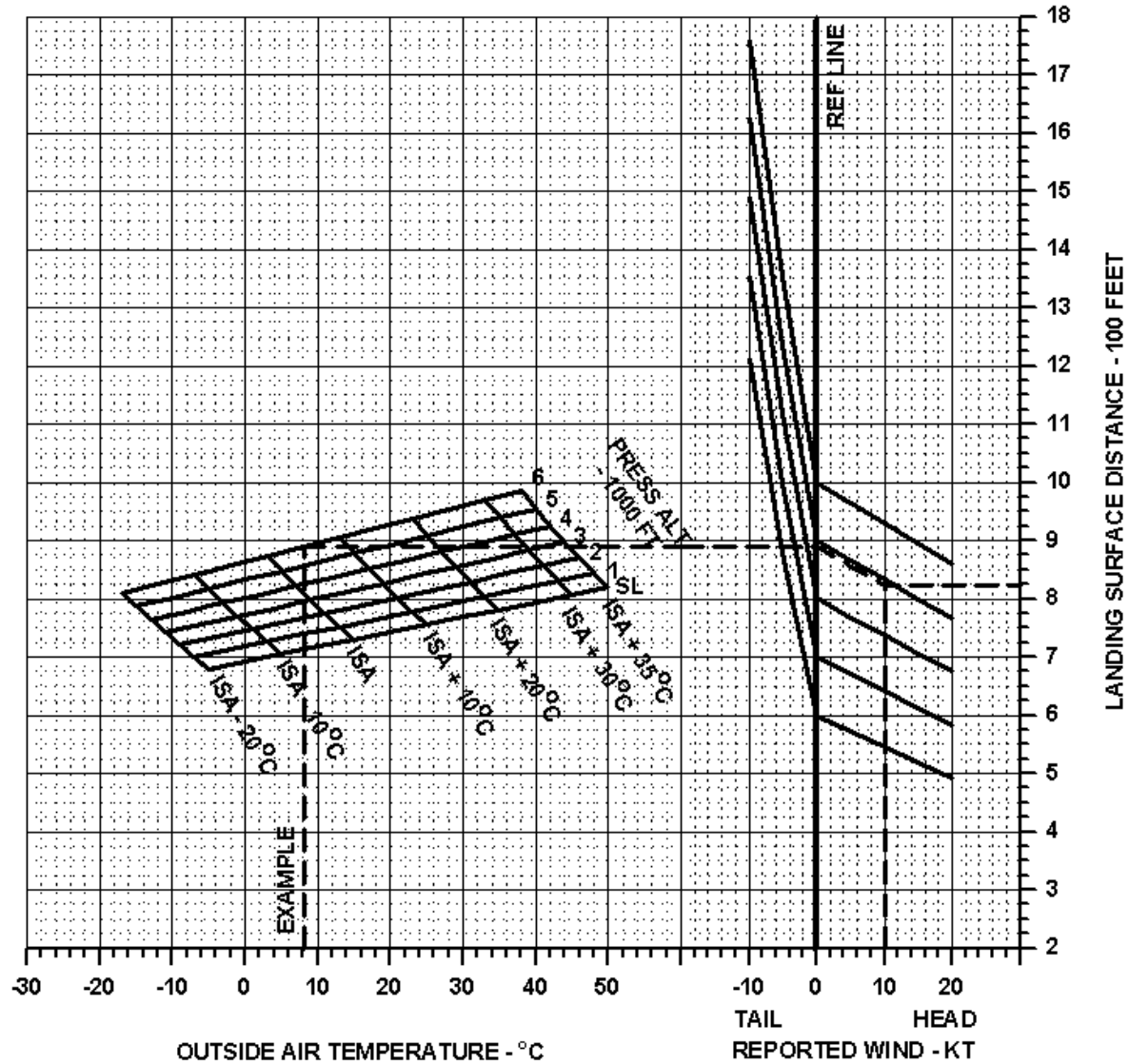


Figure 9-11-12 Landing Ground Distance with Wipaire 2100A Amphibious Floats - Water

INTENTIONALLY LEFT BLANK

9.11.5.4.4 LANDING WITH 50' OBSTACLE: WATER

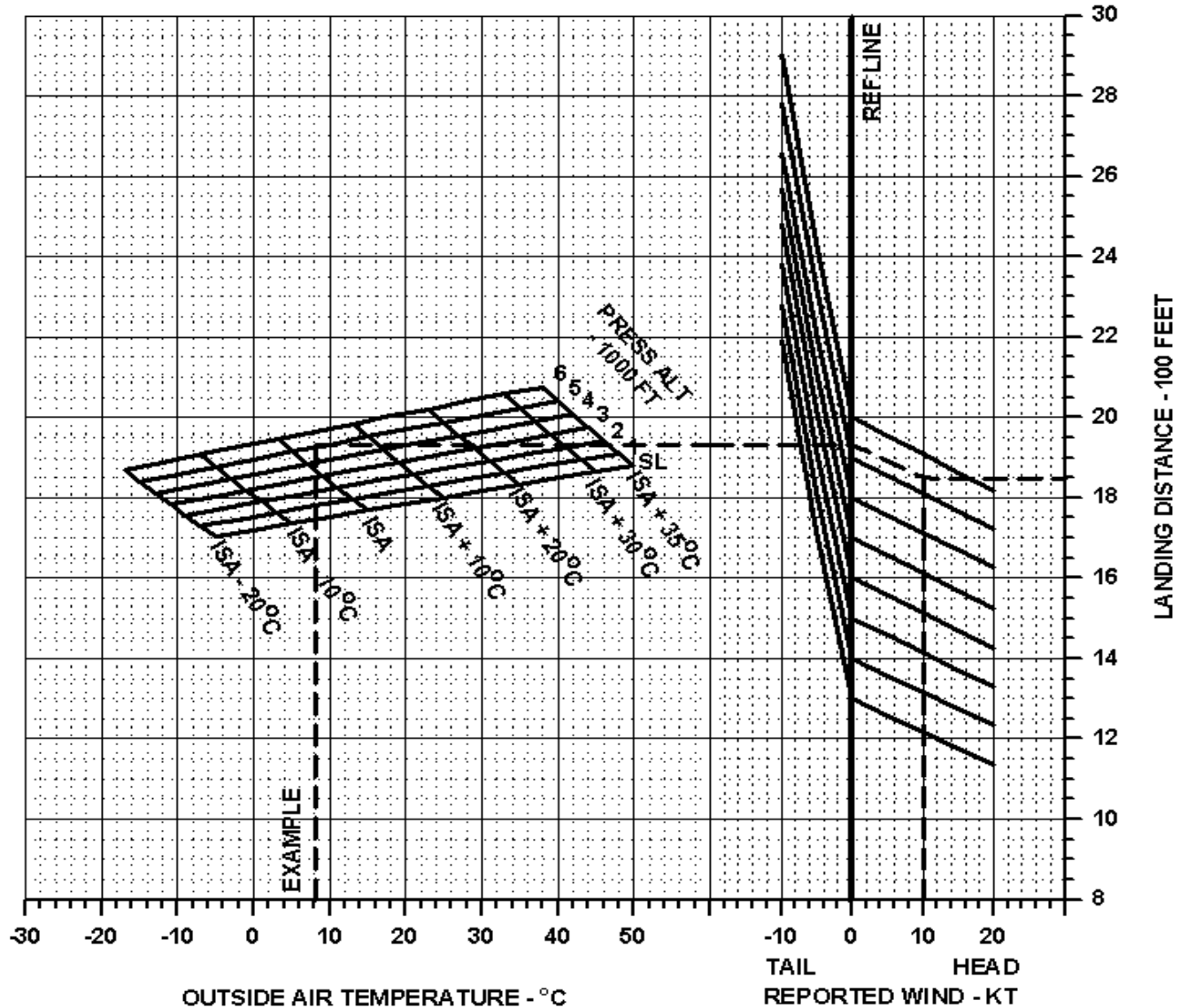


Figure 9-11-11 Landing Distance from 50' Obstacle at 2300 lb. with Wipaire 2100A Amphibious Floats - Water

INTENTIONALLY LEFT BLANK

9.11.5.6 BALKED LANDING

Pressure altitude (ft)	Airspeed (IAS)		Climb gradient (%)
	MPH	KTS	
5,000	58	50	4%

Figure-9-11-14 Balked Landing Climb Gradient with Wipaure 2100A Amphibious Floats

NOTE
Mixture leaned for peak RPM

9.11.5.7 GLIDE

Statute miles	Nautical miles	Altitude loss (feet)
1.3	1.1	1000
2.6	2.2	2000
3.8	3.3	3000
5.1	4.5	4000
6.4	5.6	5000
7.7	6.7	6000
9.0	7.8	7000
10.3	8.9	8000
11.5	10.0	9000
12.8	11.1	10000
14.1	12.3	11000
15.4	13.4	12000

Figure 9-11-15 Glide Performance with Wipaure 2100A Amphibious Floats

NOTE
At 2300 lbs. glide speed 68 MPH or 59 KTS, flaps up

9.11.6 WEIGHT AND BALANCE

9.11.6.1 INTRODUCTION

This section provides the position of the center of gravity relative to the datum. It also describes how to calculate the empty weight of the aircraft based on data for the landplane. Should it be necessary to weigh the aircraft on amphibious floats, please consult the CC18-180 maintenance manual, document TC10000AMM.

9.11.6.2 PERTINENT INFORMATION FOR WEIGHT AND BALANCE FOR THE CC18-180 EQUIPPED WITH Wipaire 2100A FLOATS

Position of datum..... 60 inches ahead
of wing leading edge

Maximum gross weight..... 2300 lbs.

Center of gravity limits at 2300 lbs.

Forward 75.0 in. aft of datum

Aft 79.0 in. aft of datum

Center of gravity limits at 1600 lbs. or less

Forward 70.5 in. aft of datum

Aft 79.0 in. aft of datum

Minimum operating weight 1300 lbs.

The CC18-180 must not be operated under 1300 lbs. It is very unlikely that a pilot will ever encounter this situation, given the empty weight of the standard aircraft with a pilot and adequate fuel.

9.11.6.3 DETERMINATION OF EMPTY WEIGHT

The empty weight and the position of the center of gravity are recorded in Section 6 of this manual.

The weight and moments of the Wipaire 2100A amphibious float system are given in Table 9-11-1.

Item	WT lbs.	Arm in.
2100A amphibious floats with attachment gear, oar and bilge pumps Left float S/N _____ Right float S/N _____		
Hydraulic power pack		

Table 9-11-1 Weight of Wipaire 2100A Amphibious Floats

**SECTION 9.11
SUPPLEMENTS-WIPAIRE
2100A AMPHIBIOUS FLOATS**

**CUB CRAFTERS
CC18-180**

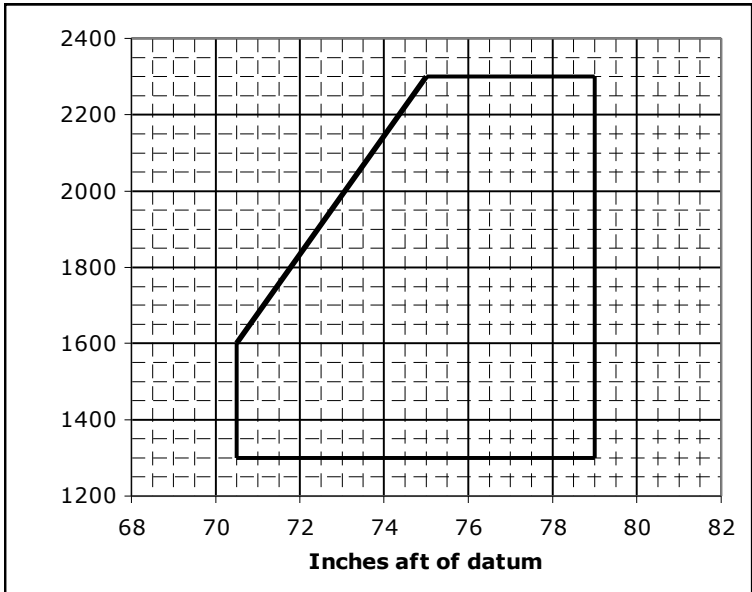
**9.11.6.4 WEIGHT AND BALANCE DETERMINATION
FOR FLIGHT**

In order to calculate the weight and balance of the aircraft:

1. Insert the respective loads in Table 9-11-2.
2. Multiply each load by its respective arm and note the moment.
3. Add the loads to calculate the takeoff weight.
4. Add the moments to compute the total moment.
5. Divide the moment by the takeoff weight. This is the final position of the center of gravity.
6. Plot the point on Figure 9-11-16. The point must be within the approved envelope for any operations.

	Weight (lbs.)	Arm (in.)	Moment (in.-lbs.)
Basic empty weight			
Float hatches (50 lbs. limit)		55	
Pilot		71	
Passenger		97	
Fuel		84	
Cargo under seat (5 lbs. limit)		97	
Forward cargo compartment (behind passenger) (180 lbs. limit)		117	
Extended cargo compartment (behind forward compartment) (20 lbs. limit)		153	
Storage/accessory compartment	NO STOWAGE ALLOWED WHEN THE HYDRAULIC PUMP IS INSTALLED		
Takeoff weight			

**Table 9-11-2 Weight and Balance Loading Form with
Wipaire 2100A floats**



**Figure 9-11-16 Weight and Balance Envelope with Wipaire
2100A Amphibious Floats**

**SECTION 9.11
SUPPLEMENTS-WIPAIRE
2100A AMPHIBIOUS FLOATS**

**CUB CRAFTERS
CC18-180**

**9.11.6.5 SAMPLE WEIGHT AND BALANCE
CALCULATION**

This section will provide a sample weight and balance calculation using the methods given in paragraph 9.11.6.4.

	Weight (lbs.)	Arm (in.)	Moment (lb-in)
Basic empty weight (inc. oil and unusable fuel)	1,450	70	101,500
Float hatches (50 lbs. limit)	50	55	2,875
Pilot	230	71	16,330
Passenger	200	97	19,400
Fuel	200	84	16,800
Cargo under seat (5 lbs. limit)	5	97	485
Forward cargo compartment (behind passenger) (180 lbs. limit)	50	117	5,850
Extended cargo compartment (behind forward compartment) (20 lbs. limit)	20	153	3,060
Storage/accessory compartment	NO STOWAGE ALLOWED WHEN THE HYDRAULIC PUMP IS INSTALLED		
Takeoff weight	2,205	75.4	166,300

**Table 9-11-3 Sample Weight and Balance with Wipaire
2100A Amphibious Floats**

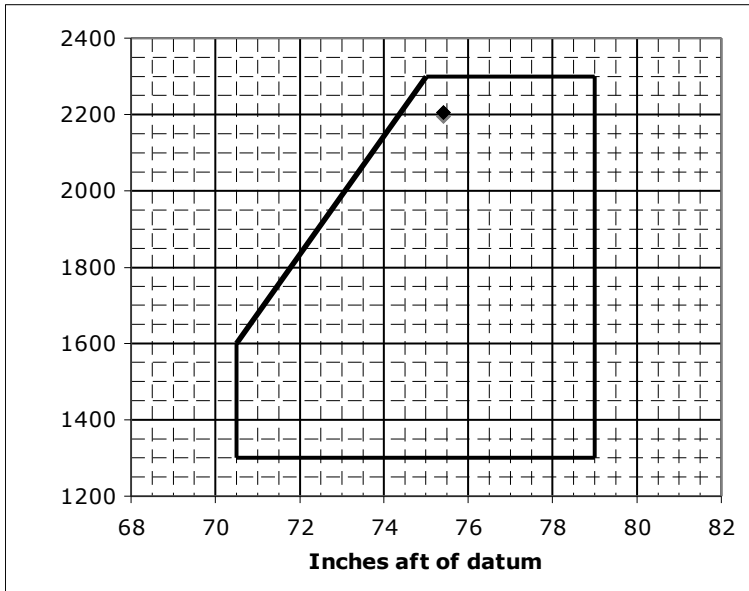


Figure9-11-17 Sample Loading Calculation

9.11.7 DESCRIPTION AND OPERATION

9.11.7.1 GENERAL

Water operation procedures are similar to any floatplane. The instructions contained in this section will relate to the operation of the landing gear and to specific features of the Wipaire 2100A amphibious floats.

The landing gear retraction mechanism is powered by an electro hydraulic power pack located in the accessory compartment. An emergency hand pump is provided for retraction or extension of the landing gear in case of power or electrical failure.

**SECTION 9.11
SUPPLEMENTS-WIPAIRE
2100A AMPHIBIOUS FLOATS**

**CUB CRAFTERS
CC18-180**

9.11.7.2 INSTRUMENT PANEL

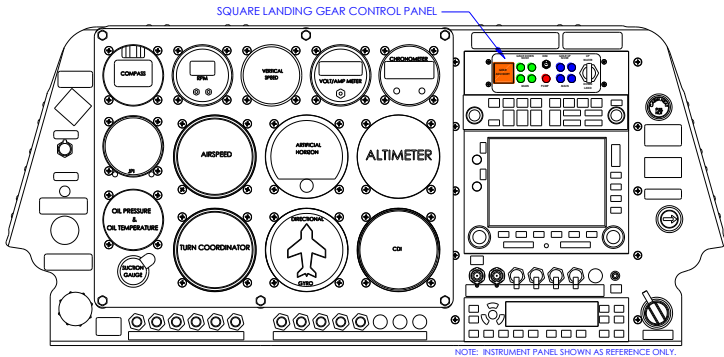


Figure 9-11-18 Instrument Panel with Square Landing Gear Control Panel [All serial numbers]

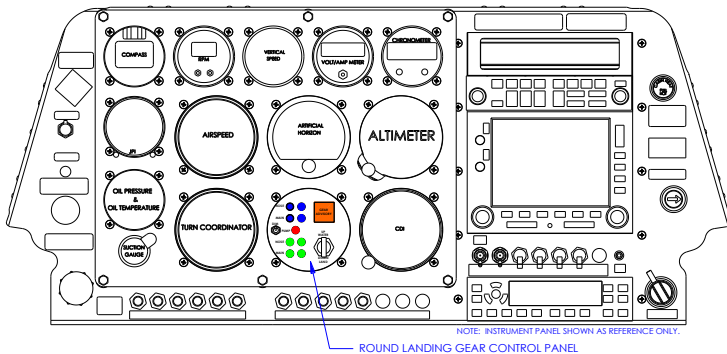


Figure 9-11-19 Instrument Panel with Round Landing Gear Control Panel [Serial numbers 18-0002 through 18-0054]

Figure 9-11-20 shows the square landing gear control panel. The gear selector is located on the right side of the panel.

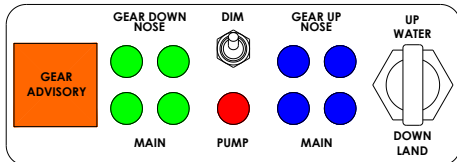


Figure 9-11-20 Square Landing Gear Control Panel

[All serial numbers]

The round landing gear control panel is shown in Figure 9-11-21. The gear selector is located on the lower right side of the panel underneath the gear advisory.

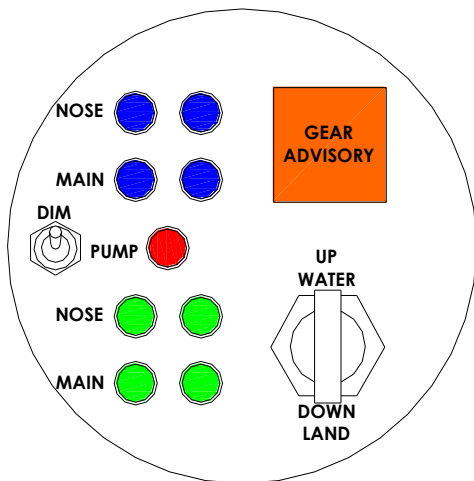


Figure 9-11-21 Round Landing Gear Control Panel
[Serial numbers 18-0002 through 18-0054]

A set of four blue lights (one for each wheel) indicates that the landing gear is in the up position. A set of four green lights indicates that the landing gear is in the down position. The four green lights are the only means of identifying that landing gear is locked in the down position.

The gear up and locked may also be confirmed by the position of the visual indicators on the deck of the floats.

9.11.7.3 LANDING GEAR POSITION ADVISORY SYSTEM

The aircraft is equipped with a Lake & Air Amphibious Landing Gear Position Advisory System. The system is activated when the master switch is turned on. It arms itself after the airspeed reaches 65 MPH or 56 KTS. After that, once the aircraft slows down below 65 MPH or 56

KTS, the Landing Gear Position Advisory System will provide an aural advisory to the headsets and the annunciator light will come on. The advisories will repeat every 5.5 seconds until the pilot presses the amber annunciator light which will cancel the advisories. In the event of a go-around, the system will arm itself automatically once the airspeed reaches 65 MPH or 56 KTS.

CAUTION

The Landing Gear Position Advisory System should not be relied upon to indicate the position of the landing gear. Always refer to the landing gear position lights.

9.11.7.4 LANDING GEAR HYDRAULIC PUMPS

A red light marked "PUMP" is provided to warn the pilot that the hydraulic power pack is running during the time the gear is in transit. It should shut off automatically after the landing gear is locked in the selected position. Should the pump not shut off once the landing gear is locked, the power can be manually turned off by pulling out the landing gear circuit breaker. The gear can still be operated using the power pack by turning the power back on (pushing the landing gear circuit breaker in) and by selecting the desired position and again, manually turning the power off, if necessary.

The pressure switch that activates the hydraulic pump is also designed to turn on the power pack when pressure in the system drops below a certain value. Therefore, if the pump comes on momentarily when turning on the master switch, or if the red light briefly illuminates during flight, it means that pressure has fallen and the pump is coming on to build it up. A sight gauge is provided on the power pack reservoir and the level should be kept in the upper 25% of the range. If the pump is running

continuously, it could mean that there is a leak in the hydraulic system.

An emergency hand pump is located on the floor to the right of the front seat. It should be used to retract or extend the landing gear when the normal hydraulic system fails.



Figure 9-11-22 Emergency Hydraulic Hand Pump

Prior to utilizing the emergency hand pump, pull the circuit breaker to deactivate the electric hydraulic pump. At night, turn the E. Pump Light on. Select UP or DOWN using the emergency landing gear selector handle. Pump vertically (approximately as much as 120 cycles for extension or retraction) with the emergency hand pump. When a gear reaches the selected position, its indicator light will illuminate. After all four gears are in the selected position there is a noted increase in the resistance of the operation of the hand pump.

The landing gear is mechanically locked in the down and the up positions. If there has been a leak in the hydraulic system, it may not be possible to retract or extend the landing gear.

Check the position of the landing gear selector prior to re-setting the circuit breaker and ensure that the landing gear selector is in the correct position.

**WARNING
DO NOT ATTEMPT TO LAND ON WATER UNLESS
ALL FOUR WHEELS ARE IN THE RETRACTED
POSITION**

9.11.7.5 FUEL QUANTITY INDICATORS

To determine the fuel quantity on the ground, use the fuel quantity indication for level flight. Fuel indications in the water will vary depending on the angle at which the aircraft is floating. Generally, using the markings for level flight will ensure that the amount of fuel available is greater than what is shown on the gauges. However, the additional weight of this fuel must be taken into account for weight and balance.

9.11.7.6 BILGE PUMP

There is a bilge pump that is stowed in the hatch in the right float. Any water that has accumulated in the floats may be emptied out by removing the rubber plugs and using the pump to draw the water out. Make sure that no one is standing in the way of the water stream.

9.12 SUPERIOR AIR PARTS O-360-A3A2 ENGINE

9.12.1 GENERAL

This supplement must be attached to the Pilot's Operating Handbook and FAA Approved Airplane Flight Manual when the Superior Air Parts O-360-A3A2 engine is installed. The information contained herein supplements or supersedes the Pilot's Operating Handbook and FAA Approved Flight Manual only in those areas listed in this supplement. For limitations, procedures and performance information not contained in this supplement, consult Section 2 of this Pilot's Operating Handbook and FAA Approved Airplane Flight Manual.

This supplement has been FAA approved as a permanent part of the handbook and must remain in the handbook at all times when the Superior Air Parts O-360-A3A2 is installed.

FAA APPROVED _____



DATE: _____

8-1-12

9.12.1.1 DESCRIPTION

The Superior Air Parts O-360-A3A2 engine is a horizontally opposed air-cooled engine capable of delivering 180 HP. It is very similar to the Lycoming engines listed in the main section of this manual.

9.12.2 LIMITATIONS

9.12.2.1 GENERAL

This section provides the FAA Approved operating limitations, instrument markings, color-coding and basic placards for operation that are specific to the Cub Crafters CC18-180 aircraft equipped with the Superior Air Parts O-360-A3A2 engine.

Please refer to Section 2 of this manual for the complete list of FAA Approved operating limitations, instrument markings, color-coding and basic placards for operation that are common to all engine types approved on the CC18-180.

9.12.2.2 POWERPLANT LIMITATIONS

Engine manufacturer	Superior Air Parts
Engine model number	O-360-A3A2
Engine operating limits:	
Takeoff power	180 BHP
Transient operation only	2150-2350 RPM
	(Only when Sensenich 76EM8 is installed)
Maximum engine speed	2700 RPM
Oil pressure, minimum	25 PSI
Oil pressure, maximum	115 PSI
Oil temperature	240 °F/116 °C
Fuel limitations (grade)	100 or 100LL
Maximum cylinder head temperature.....	500°F/260°C
	If equipped with CHT gauge.

9.12.3 POWERPLANT INSTRUMENT MARKINGS

TACHOMETER	Red Radial Line	2700 RPM	
	Red Arc (Transient operations only)	2150–2350 RPM	
	Green Arc (Normal operating range)	500-2149 RPM 2351-2699 RPM	
OIL PRESSURE	Red Radial Line (minimum)	24 PSI	
	Yellow Arc (caution, low)	25-59 PSI	
	Green Arc (normal)	60-94 PSI	
	Yellow Arc (caution, high)	95-114 PSI	
	Red Radial Line (maximum)	115 PSI	
OIL TEMPERATURE	Yellow Arc *	0-99°F	-18-37°C
	Green Arc (normal)	100-239°F	38-115°C
	Red Radial Line (maximum)	240°F	116°C

Table 2-2 Powerplant Instrument Markings with Sensenich 76EM8 Propeller

**SECTION 9.12
SUPPLEMENTS-
SUPERIOR AIR PARTS O-360-A3A2 ENGINE**

**CUB CRAFTERS
CC18-180**

TACHOMETER	Red Radial Line	2700 RPM	
	Green Arc (Normal operating range)	500-2699 RPM	
OIL PRESSURE	Red Radial Line (minimum)	24 PSI	
	Yellow Arc (caution, low)	25-59 PSI	
	Green Arc (normal)	60-94 PSI	
	Yellow Arc (caution, high)	95-114 PSI	
	Red Radial Line (maximum)	115 PSI	
OIL TEMPERATURE	Yellow Arc *	0-99°F	-18-37°C
	Green Arc (normal)	100-239°F	38-115°C
	Red Radial Line (maximum)	240°F	116°C

Table 2-2 Powerplant Instrument Markings with McCauley Propeller Systems 1A200/FA8240 Propeller

NOTE

The only propellers approved for use with the O-360-A3A2 are the Sensenich Propeller 76EM8 56 and the McCauley Propeller Systems 1A200/FA8240.

NOTE

* A yellow low oil temperature indication below 100°F is a cautionary indication provided to emphasize when the engine is operating outside the normal range. Takeoff must not be initiated when the oil temperature is below 100°F unless the engine accelerates smoothly when the throttle is opened.

9.12.4 EMERGENCY PROCEDURES

There are no changes to emergency procedures. See Section 4 of this manual.

9.12.5 PERFORMANCE

No change.

9.12.6 WEIGHT AND BALANCE

No change.

9.12.7 DESCRIPTION AND OPERATION

The Superior Air Parts O-360-A3A2 engine is virtually identical to the Lycoming O-360-C1G. From the pilot's perspective, the only difference is that the maximum oil temperature limit is 240°F. Like on the Lycoming O-360-C1G, operation of the engine between 2150 and 2350 RPM is limited to transient operations only and when the Sensenich Propeller 76EM8 propeller is installed.

INTENTIONALLY LEFT BLANK

9.13 WIPAIRE 2100S SEAPLANE FLOATS

9.13.1 GENERAL

This supplement must be attached to the Pilot's Operating Handbook and FAA Approved Airplane Flight Manual when the WIPAIRE 2100S seaplane floats are installed per the Equipment List supplied with the aircraft and listed in Section 6 of this manual. The information contained herein supplements or supersedes the Pilot's Operating Handbook and FAA Approved Flight Manual only in those areas listed in this supplement. For limitations, procedures and performance information not contained in this supplement, consult section 2 of this Pilot's Operating Handbook and FAA Approved Airplane Flight Manual.

This supplement has been FAA approved as a permanent part of the handbook and must remain in the handbook at all times when the WIPAIRE 2100S seaplane floats are installed.

9.13.1.1 DESCRIPTION

The WIPAIRE 2100S seaplane floats are constructed from aluminum. They have retractable rudders and are of conventional design with a single step.

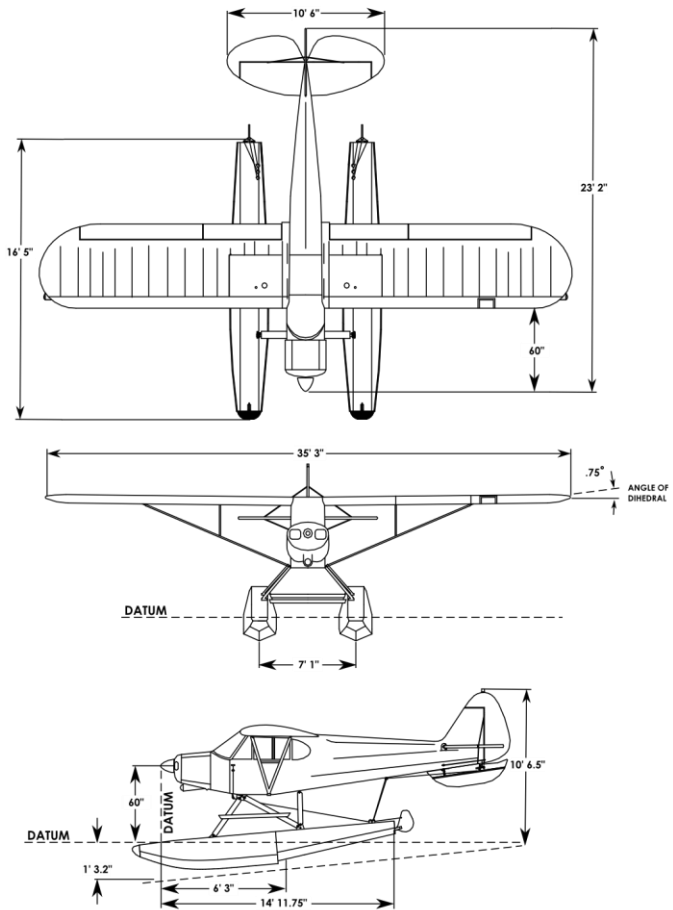


Figure 9-13-1 Three Views of the CC18-180 with Wipaire 2100S Seaplane Floats

9.13.2 LIMITATIONS

9.13.2.1 GENERAL

This section provides the FAA Approved operating limitations, instrument markings, color-coding and basic placards for operation that are specific to the Cub Crafters CC18-180 aircraft equipped with WIPAIRE 2100S seaplane floats.

Please refer to Section 2 of this manual for the complete list of FAA Approved operating limitations, instrument markings, color-coding and basic placards for operation that are common to the landplane and the version equipped with WIPAIRE 2100S seaplane floats.

9.13.2.2 CENTER OF GRAVITY

Forward (at 2300 lb.)75.0 in. aft of Datum
(at 1600 lb. or less).....70.5 in. aft of Datum
Straight line variation between points given
Rearward (at all weights)79.0 in. aft of Datum

The datum is 60 in. forward of wing leading edge.

9.13.2.3 PLACARDS

Locate near water rudder retraction handle stowage hook:

**WATER RUDDER UP
FOR ALL FLIGHT OPERATIONS**

In view of the pilot:

**REFER TO SECTION 9.13 OF THE AFM FOR OPERATION
WITH WIPAIRE 2100S SEAPLANE FLOATS**

Next to the water rudder retraction handle:

WATER RUDDER CONTROL

Inside float hatches:

**MAX. CAPACITY 50 lb
ARM 55.0 IN**

Locate on both sides of Ventral Fin:

NO PUSH

9.13.3 EMERGENCY PROCEDURES

9.13.3.1 GENERAL

This section provides the procedures that Cub Crafters recommends should be followed when encountering an emergency or a critical situation as related specifically to operations when the WIPAIRE 2100S seaplane floats are installed. For all other emergency procedures, refer to section 3 of this manual.

This section is divided into two parts. The first contains emergency procedure checklists. The second part amplifies the items listed in the checklists and includes information that is not readily adaptable to a checklist format or which the pilot could not be expected to refer to in an emergency situation. This information should be reviewed regularly.

Pilots must familiarize themselves with the procedures in this section and must be prepared to take appropriate action should an emergency arise.

It is stressed that the procedures outlined in this section are recommendations only. They are not a substitute for sound judgment and common sense and may have to be adjusted depending on the circumstances prevailing at the time of the emergency. It is important that the pilot be thoroughly familiar with the aircraft. She/he must review and practice as many of these procedures as are safe to perform as part of his/her training. Above all, in any emergency situation, **MAINTAIN CONTROL OF THE AIRCRAFT.**

**9.13.3.2 AIRSPEEDS FOR EMERGENCY
OPERATIONS**

AT MAXIMUM WEIGHT OF 2300 LB	IAS	
	MPH	KNOTS
STALL SPEED		
Flaps Up (V_{S1})	53	46
Flaps Down (50°) (V_{S0})	48	42
BEST GLIDE (V_G)		
Flaps Up	68	59

Configuration:

Landing gear retracted, flaps up

9.13.3.3 EMERGENCY CHECKLIST

9.13.3.3.1 Emergency Landing without Engine Power

	IAS	
	MPH	KNOTS
• Airspeed (flaps up)	68	59
• Seat belts	Tight and secure	

When landing area assured:

- Flaps As required
- Door Open
- ELT Activate
- Touchdown..... Slightly tail low
- Control stick Hold full aft

When aircraft comes to a stop:

- Ignition..... Off
- Master switch Off
- Fuel selector..... Off

If time permits, check GPS or charts for airports in the immediate vicinity. If possible, notify your difficulty and intentions by radio and/or squawk 7700.

9.13.3.4 AMPLIFIED PROCEDURES EMERGENCY

9.13.3.4.1 Total Loss of Engine Power in Flight

The CC18-180 equipped with WIPAIRE 2100S seaplane floats will glide 1.1 nautical miles for every 1000 feet of altitude loss. The rate of descent will be approximately 890 feet per minute. Most GPS have a “Direct to” function that shows the closest airports. Use charts to assess the topography of airports in the immediate vicinity, especially considering that the airplane has no wheels.

9.13.3.4.2 Emergency Landing without Engine Power

Over and above the procedures described in Section 3, special attention must be paid to the fact that on uneven land the floats may cause the aircraft to turn over. If landing on open water, consider wave height and wind direction.

9.13.4 NORMAL PROCEDURES

9.13.4.1 INTRODUCTION

This section describes the procedures that Cub Crafters recommends for the pilot to follow during normal operations of the CC18-180 on WIPAIRE 2100S seaplane floats. It is divided into two parts. The first has abbreviated checklists; these are in a format suitable for reference in the cockpit. The second part amplifies the information given in the checklists. It provides the pilot with detailed descriptions that will help him/her understand the procedures and techniques. This section contains complete checklists so that the pilot can carry

out these activities out without having to turn back and forth in this manual.

9.13.4.2 AIRSPEEDS FOR NORMAL OPERATIONS

The speeds in this section are based on a maximum weight of 2300 lb, under standard conditions, at sea level.

SPEED	IAS	
	MPH	KNOTS
Never Exceed Speed V_{NE}	152	132
Operating Maneuvering Speed V_O	102	88
Maximum Flap Speed (V_{FE}) Flaps 50°	89	77
Best rate of climb speed (V_Y)	74	64
Best angle of climb speed (V_X)	63	55
Maximum demonstrated crosswind velocity	11 kts	

9.13.4.3 MAXIMUM WAVE HEIGHT

Maximum demonstrated wave height..... 1 ft

9.13.4.4 NORMAL PROCEDURES CHECKLIST

For ease of operation, this supplement will provide the complete checklist.

9.13.4.4.1 Cockpit Preflight

- Flight controls Free and correct operation
- Trim..... Check operation and set for takeoff
- Fuel selector Both
- Flaps Proper operation
- Fuel gauges Sufficient fuel for intended flight
- Mixture Idle cut-off
- Carburetor heat..... Cold
- Ignition Off
- Electrical switches Off
- Water rudders Check operation and set Down
- Master switch..... On
- Navigation/strobe lights Check operation
- Landing lights..... Check operation
- Stall warning horn Check operation
- Master switch..... Off
- Circuit breakers..... Check in
- Windows Clear
- Documentation..... Onboard

If passenger seat unoccupied:

- Passenger seat harness Secure

9.13.4.4.2 Preflight Right Fuselage, Wing, and Float

- Right Fuselage Check
- Baggage Door Closed
- Accessory Door.....Closed and latched
- Tank Sump..... Drain
- Flap Surface..... Check condition
- Flap Hinges Check
- Aileron Surface..... Check condition
- Aileron Hinges..... Check
- Wing Tip and Light Check
- Stall Warning Vane Check condition
- Vortex Generators..... Check
- Tie Down Remove
- Fuel Vent..... Check
- Fuel TankCheck supply and cap for security
- Water Rudders and Cables..... Check
- Float Check for damage and water accumulation
(use bilge pump as necessary)

NOTE

Remove rubber plugs which serve as stoppers on the standpipe in each float compartment and pump out any accumulation of water. Reinstall rubber plugs with enough pressure for a snug fit.

- Bilge rubber plugs Secure
- Oar Check stowed and secure
- Float hatches.....Cargo secure and hatches latched

9.13.4.4.3 Preflight Nose Section

- Right static port..... Clear
- Right cowling Open
- Oil quantity..... Check and cap secure
(Min recommended 6 Qt or 5.7 liters)
- Engine condition Check
- Right cowling Close
- Propeller and spinner..... Check
- Air inlets Check
- Left cowling..... Open
- Engine condition Check
- Left cowling..... Close
- Fuel strainer..... Drain
- Left static port Clear

9.13.4.4.4 Preflight Left Fuselage, Wing, and Float

- Mooring ropes.....Removed
- Float hatches Cargo secure and hatches latched
- Float.....Check for damage and water accumulation
(use bilge pump as necessary)

NOTE

Remove rubber plugs which serve as stoppers on the standpipe in each float compartment and pump out any accumulation of water. Reinstall rubber plugs with enough pressure for a snug fit.

- Bilge rubber plugs.....Secure
- Fuel tank..... Check supply and cap for security
- Fuel vent..... Check
- Tie down Remove
- Landing light Check condition
- Pitot tube..... Check condition
- Wing tip and light Check condition
- Vortex generators Check

- Aileron hinges Check
- Aileron surface Check condition
- Flap hinges..... Check
- Flap surface Check condition
- Tank sump Drain
- Water rudders and cables Check
- Left fuselage..... Check

9.13.4.4.5 Empennage

- Bracing wires.....Check for tension
- Hinges Check
- Surfaces Check
- Ventral fin Check
- Tie down..... Remove

9.13.4.4.6 Preflight General

Check that all wings and other external surfaces are free from frost, ice or snow.

9.13.4.4.7 Startup and Taxi

- Preflight inspection..... Complete
- Pilot seat Adjusted
- Seat belts Fastened
- Passenger briefing Complete
- Door Closed
- Fuel selector..... Both
- Avionics master switch..... Off
- Water ruddersDown for water
Up for flight
- Propeller area..... Clear

9.13.4.4.8 Starting Engine

- Battery master switch On
- Beacon..... On
- Ignition switchesBoth on
- Mixture Full rich
- PrimerApply*
- Throttle.....Open 1/2 inch
- Starter..... Engage

After engine has started:

- Oil pressureCheck
- Throttle.....Set 1000 RPM
- LightsAs required
- Avionics master switch On

*Normal procedure 3 times. If engine is hot, omit this step.

9.13.4.4.9 Starting Engine When Flooded

- IgnitionBoth
- Mixture Idle cut-off
- Throttle..... Full open
- Starter Engage

When engine fires:

- Mixture Rich
- Throttle..... Retard to 1000 RPM
- Oil pressureCheck
- LightsAs required
- Avionics master switch On

9.13.4.4.10 Warm up

- Throttle 1000 to 1200 RPM

9.13.4.4.11 Taxiing

- Taxi area Clear
- Throttle Apply slowly
- Pitot heat (if required) On

9.13.4.4.12 Before Takeoff

- Throttle 1700 RPM*
- Ignition..... Check
Drop not to exceed 175 RPM or 50 RPM differential
between magnetos and no engine roughness
- Carburetor heat Hot, note RPM drop and remove
- Engine instruments Check
- Ammeter..... Check
- Throttle Check idle
- Throttle 1000 RPM
- Flight instruments..... Check
- Fuel selector..... Both and sufficient qty for flight
- Engine gauges Check
- Mixture Set*
- Ignition..... Both
- Carburetor heat Off (cold)
- Primer..... Locked
- Trim Set
- Flaps First notch (takeoff 22°)
- Controls..... Free and proper movement
- Doors..... Closed
- Strobes and lights As required
- Transponder and other avionics..... On
- Seat belts Check fastened

* When operating at high altitudes and/or temperatures, it may be necessary to lean the mixture for peak RPM.

9.13.4.4.13 Takeoff

- Control stick Full aft
- Throttle..... Full
- Control stick Move forward when the nose stops rising to attain the planing attitude (on the step).

- | | AIRSPEED (IAS) | MPH | KNOTS |
|---|-----------------------|------------|----------------------|
| • Accelerate to
(depending on aircraft weight) | | 58 | 50 |
| • Control stick | | | Gentle back pressure |
| • Flaps | | | Retract |
| • Landing lights (if applicable) | | | Off |

9.13.4.4.14 Climb

- | | AIRSPEED (IAS) | MPH | KNOTS |
|--|-----------------------|------------|--------------|
| • Best Rate | | 74 | 64 |
| • Best Angle | | 63 | 55 |
| • Mixture | | | Rich |
| • Above 3000' LEAN to obtain maximum RPM | | | |
| • Carburetor heat..... | | | As required |

9.13.4.4.15 Cruise

- Power..... Adjust
- Mixture
- Carburetor heat.....As required

9.13.4.4.16 Descent

- Power..... Adjust
- Mixture Full rich below 3000'
- Carburetor heat.....As required

9.13.4.4.17 Approach

- Fuel Both
- Seat beltsFastened
- Mixture Set
- Flaps Set

	AIRSPEED (IAS)	MPH	KNOTS
Maximum speed first notch flaps (22°)		98	85
Maximum speed full flaps (50°)		89	77

- Trim As required
 - Speed As required
- (1.3 times full flaps stall speed at gross weight is 63 mph or 55 knots IAS)

9.13.4.4.18 Landing

- Control stick
..... Hold full aft as aircraft decelerates to taxi speed

NOTE

At a forward loading and if the control stick is not held back, the aircraft may pitch down as it comes off the step.

9.13.4.4.19 Cross Wind Landing

- Fuel selectorBoth
 - Seat belts..... Fastened
 - MixtureSet
 - FlapsSet below white arc
- | AIRSPEED (IAS) | MPH | KNOTS |
|---------------------------------------|------------|--------------|
| Maximum speed first notch flaps (22°) | 98 | 85 |
| Maximum speed full flaps (50°) | 89 | 77 |
- Trim.....As required
 - SpeedAs required
(A higher speed than normal is recommended)
 - Ailerons-rudderOn short final
Use ailerons to keep upwind wing low
Rudder to hold alignment
 - TouchdownDo not touch down in a slip
 - Landing roll Use ailerons to keep upwind wing
down, and rudder to maintain directional control
as appropriate

9.13.4.4.20 Go-around

- Throttle..... Full power
- | (IAS) | MPH | KNOTS |
|----------------|------------|--------------|
| Airspeed Above | 54 | 47 |
- FlapsRetract slowly
 - Trim.....As required

9.13.4.4.21 Stopping Engine

- Flaps Retract
- Electrical equipment Off
- Avionics master switch Off
- Throttle..... Idle

- Mixture Idle cut off
- Ignition..... Off
- Master switch Off

9.13.4.5 AMPLIFIED PROCEDURES

This section will amplify specific procedures that relate to the operation of the aircraft equipped with Wipaire 2100S seaplane floats. For amplified procedures that are common to the landplane and the floatplane, please refer to section 4 of this manual.

9.13.4.5.1 Preflight

Check the operation, retraction and extension of the water rudders.

To determine the fuel quantity on the water, use the fuel quantity indication for level flight. Fuel indications in the water will vary depending on the angle at which the aircraft is floating.

The bilge pump is located in the right float hatch. To empty the floats of water, remove the rubber plugs, and pump any accumulated water. Once the process is complete make sure that the rubber plugs are fitted tightly.

9.13.5 PERFORMANCE

9.13.5.1 INTRODUCTION

The purpose of this section is to provide information that will assist the pilot of a CC18-180 equipped with WIPAIRE 2100S seaplane floats with planning a flight in detail with reasonable accuracy.

All data has been corrected to I.C.A.O. standard day conditions. Where appropriate, the data has been expanded analytically for variations in weight, altitude, temperature, etc.

The data has been derived from actual flight tests, taking into account the proficiency of an average pilot. The pilot must use sound judgment when assessing the effect of conditions not found in the charts, such as water state and winds aloft. The parameters will be affected by the performance of the engine. Therefore, the pilot must be thoroughly familiar with its operation, including the procedures for adjusting the mixture control.

Data should not be extrapolated beyond the limits shown on the charts.

All information is presented in the units used on the aircraft's instrumentation.

- Airspeeds will be quoted in statute miles per hour.
- Weights in pounds.
- Altitudes in feet.
- Temperatures in degrees Fahrenheit.
- Wind speed in nautical miles per hour.
- Conversion Charts in Section 5.3.

PERFORMANCE CHARTS

Figure 9-13-2 Stall Speed versus Angle of Bank at 2300 lb. with Wipaire 2100S Seaplane Floats..... 23

Figure 9-13-3 Takeoff surface distance with Wipaire 2100S Seaplane Floats- Water 25

Figure 9-13-4 Takeoff distance to 50' obstacle at with Wipaire 2100S Seaplane Floats- Water 26

Figure 9-13-5 Maximum Rate and Climb Gradient of Climb at 2300 lb. with Wipaire 2100S Seaplane Floats..... 28

Figure 9-13-6 Landing distance from 50' obstacle at 2300 lb. with Wipaire 2100S Seaplane Floats- Water 29

Figure 9-13-7 Landing surface distance with Wipaire 2100S Seaplane Floats- Water 30

Figure-9-13-8 Balked Landing Climb Gradient with Wipaire 2100S Seaplane Floats 31

Figure 9-13-9 Glide Performance with Wipaire 2100S Seaplane Floats..... 32

Figure 9-13-10 Weight and Balance Envelope with Wipaire 2100S Seaplane Floats 37

Figure 9-13-11 Sample Loading Calculation 39

9.13.5.1.1 STALL SPEED

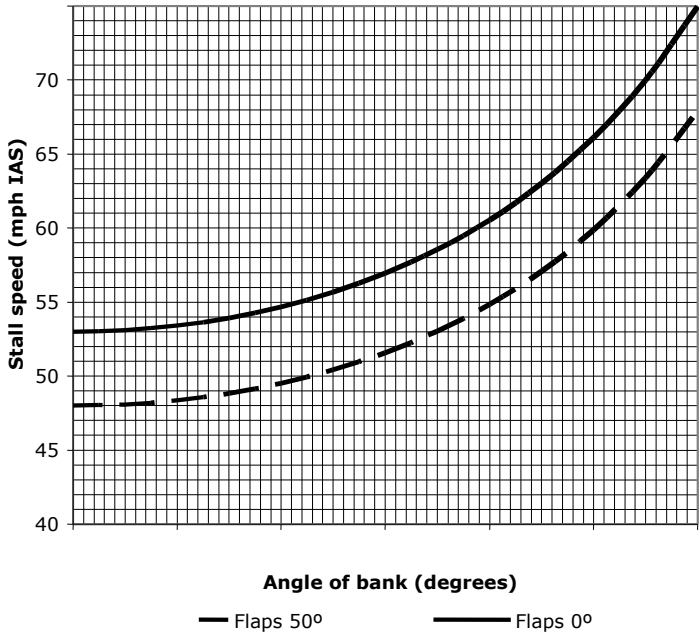


Figure 9-13-2 Stall Speed versus Angle of Bank at 2300 lb. with Wipaïre 2100S Seaplane Floats

INTENTIONALLY LEFT BLANK

9.13.5.2 TAKEOFF

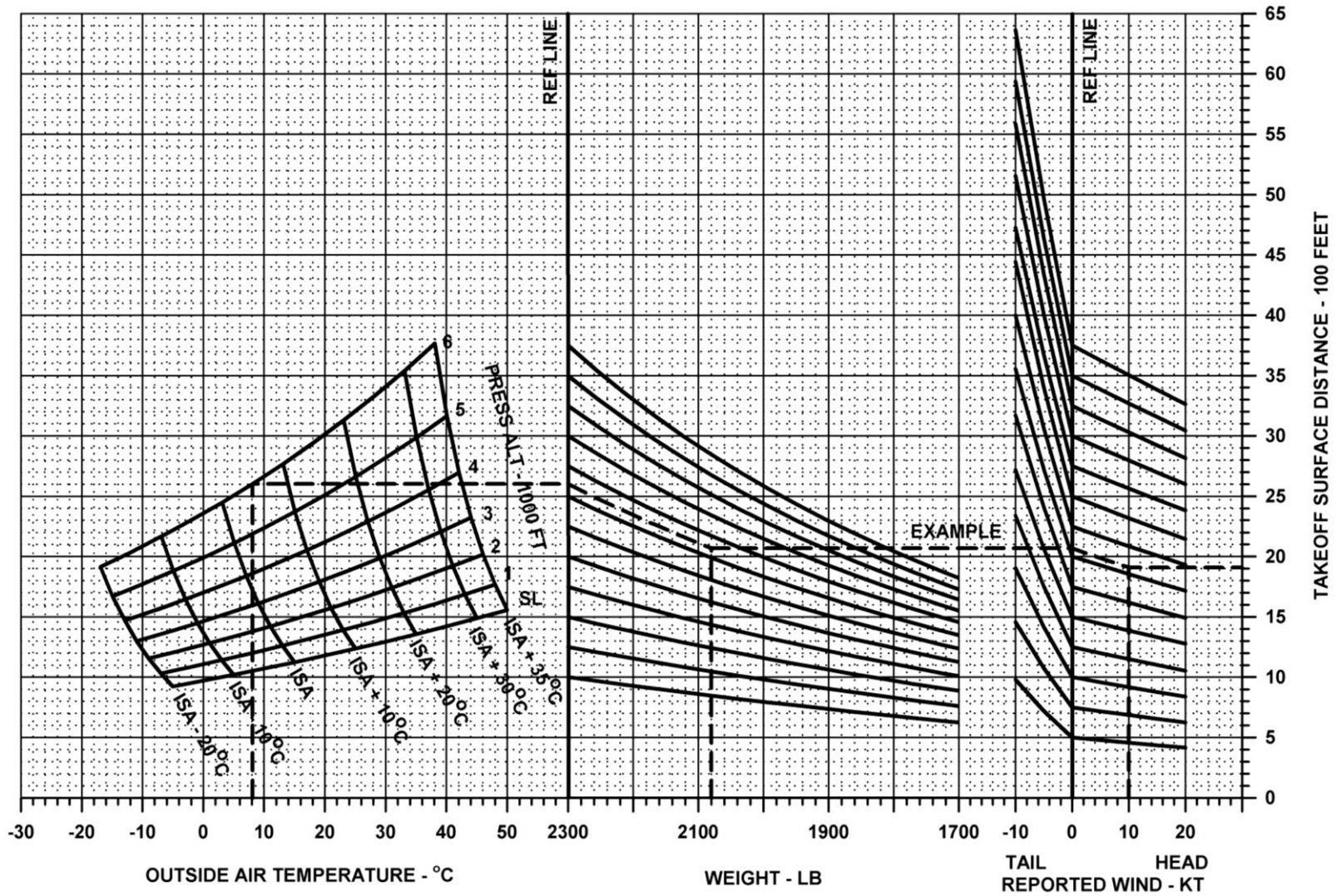


Figure 9-13-3 Takeoff Surface Distance with Wipaire 2100S Seaplane Floats - Water

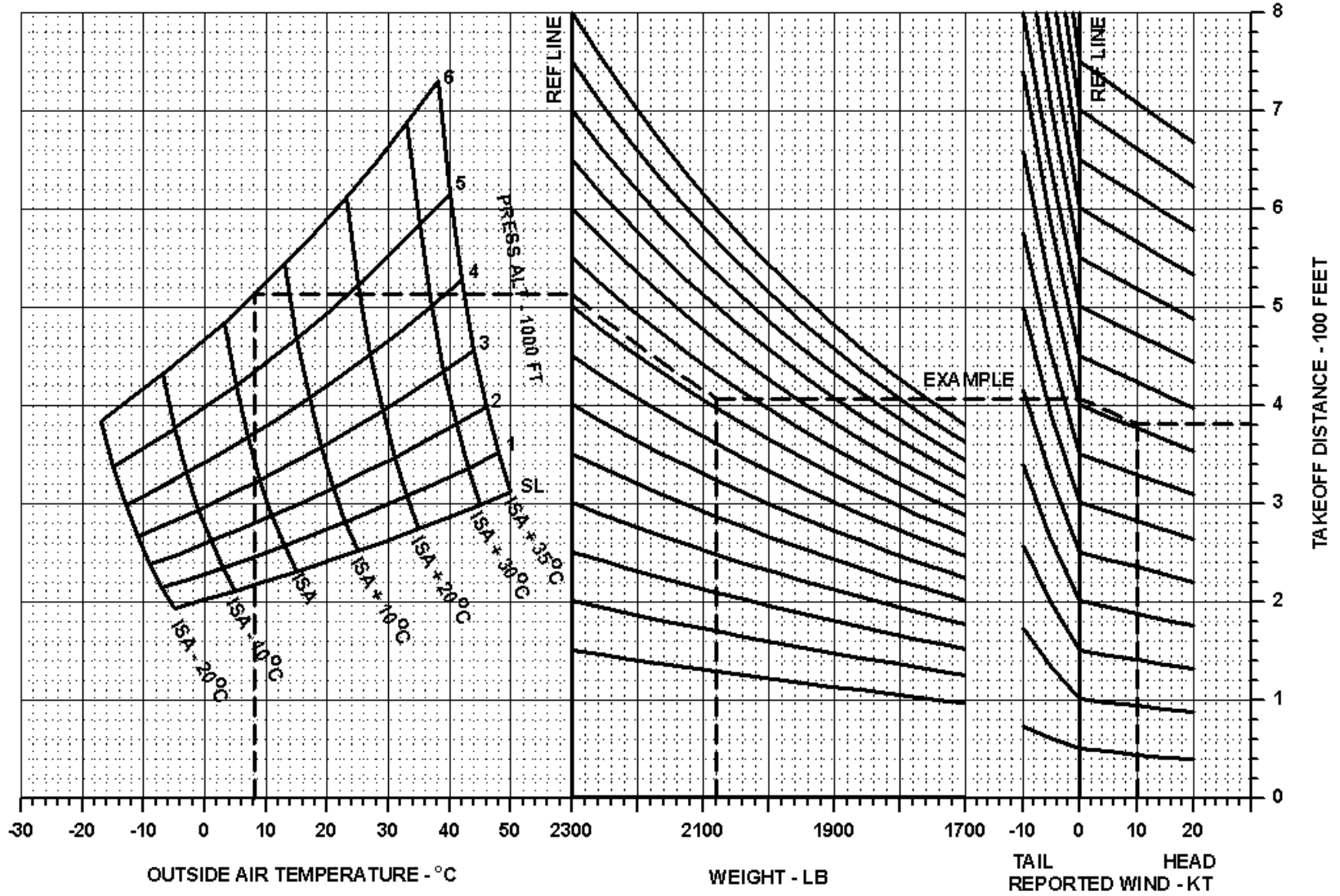


Figure 9-13-4 Takeoff Distance to 50' Obstacle with Wipaire 2100S Seaplane Floats- Water

9.13.5.3 CLIMB RATE AND GRADIENT

Pressure altitude (ft)		Airspeed (IAS)		OAT		Climb gradient %	Rate of climb (fpm)
		mph	knots	°F	°C		
0	ISA-59°F (0° F)	75	65	0	-18	12%	764
2000		73	63	-7	-22	10%	665
4000		72	63	-14	-26	9%	566
6000		71	62	-21	-29	7%	463
8000	ISA-32.8 (-17.8° C)	70	61	-29	-34	6%	366
10000		69	60	-36	-38	4%	266
12000		68	59	-43	-42	3%	165
0		ISA-27°F (32° F) ISA-15°C (0° C)	75	65	32	0	11%
2000	73		63	25	-4	10%	620
4000	72		63	18	-8	8%	527
6000	71		62	11	-12	7%	430
8000	70		61	3	-16	6%	340
6000	69		60	-4	-20	4%	246
12000	68		59	-11	-24	3%	152
0	ISA (59° F) ISA (15° C)	75	65	59	15	10%	660
2000		73	63	52	11	9%	572
4000		72	63	45	7	8%	484
6000		71	62	38	3	6%	396
8000		70	61	30	-1	5%	308
10000		69	60	23	-5	4%	220
12000		68	59	16	-9	2%	132
0		ISA+16° F (75° F) ISA+8.9° C (23.9° C)	75	65	75	24	10%
2000	73		63	68	20	9%	568
4000	72		63	61	16	8%	482
6000	71		62	54	12	6%	393
8000	70		61	46	8	5%	310
10000	69		60	39	4	4%	224
12000	68		59	32	0	2%	138

**SECTION 9.13
SUPPLEMENTS-WIPAIRE 2100S
SEAPLANE FLOATS**

**CUB CRAFTERS
CC18-180**

Pressure altitude (ft)		Airspeed (IAS)		OAT		Climb gradient %	Rate of climb (fpm)
		mph	knots	°F	°C		
0	ISA+41° F (100° F)	75	65	100	38	10%	625
2000		73	63	93	34	8%	542
4000		72	63	86	30	7%	459
6000		71	62	79	26	6%	375
8000	ISA+22.8° C (37.8° C)	70	61	71	22	5%	295
10000		69	60	64	18	4%	213
12000		68	59	57	14	2%	131

Figure 9-13-5 Maximum Rate and Climb Gradient of Climb at 2300 lb. with Wipaire 2100S Seaplane Floats

NOTE

Mixture leaned for peak EGT

9.13.5.4 LANDING

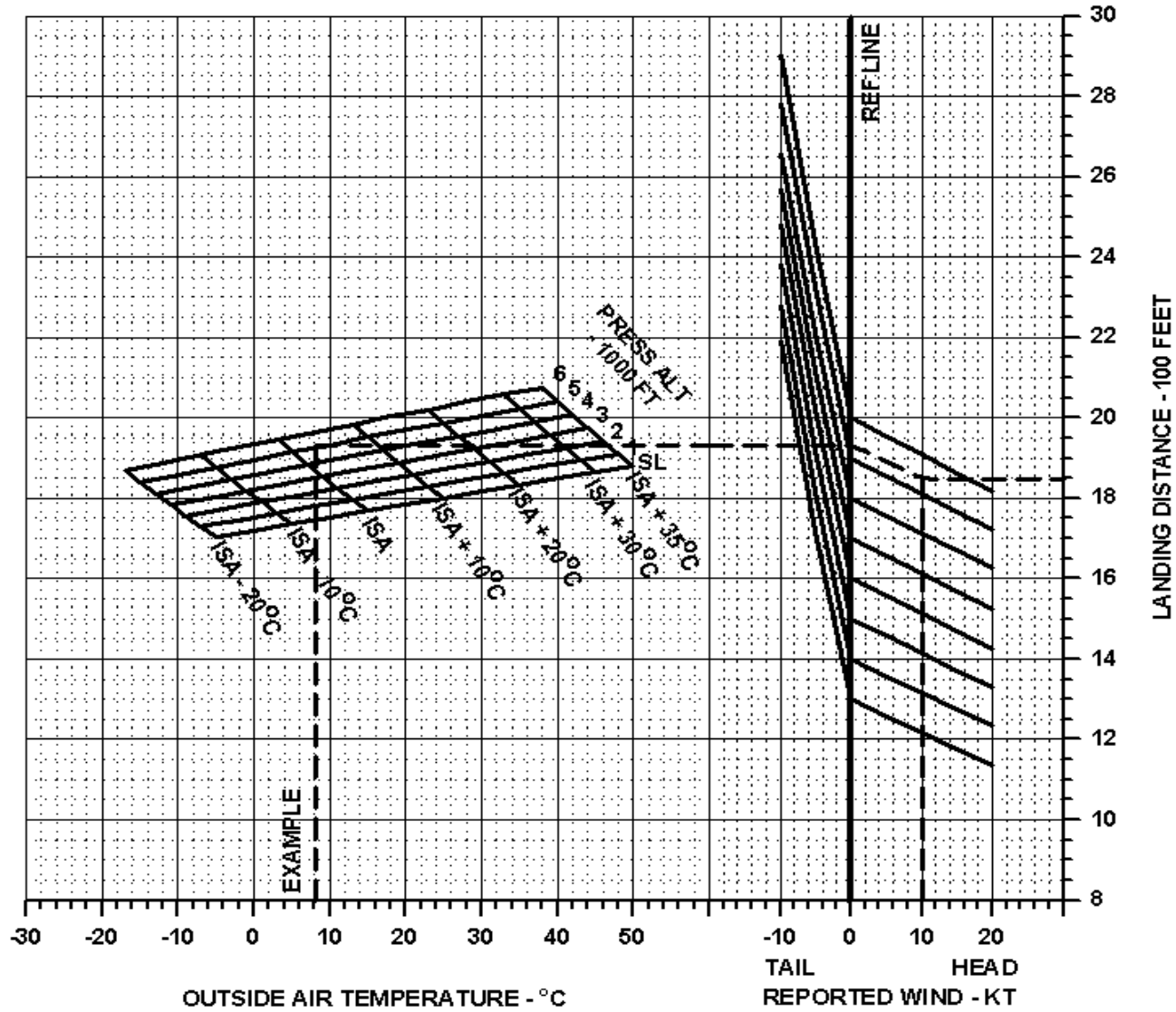


Figure 9-13-6 Landing Distance from 50' Obstacle at 2300 lb. with Wipaire 2100S Seaplane Floats - Water

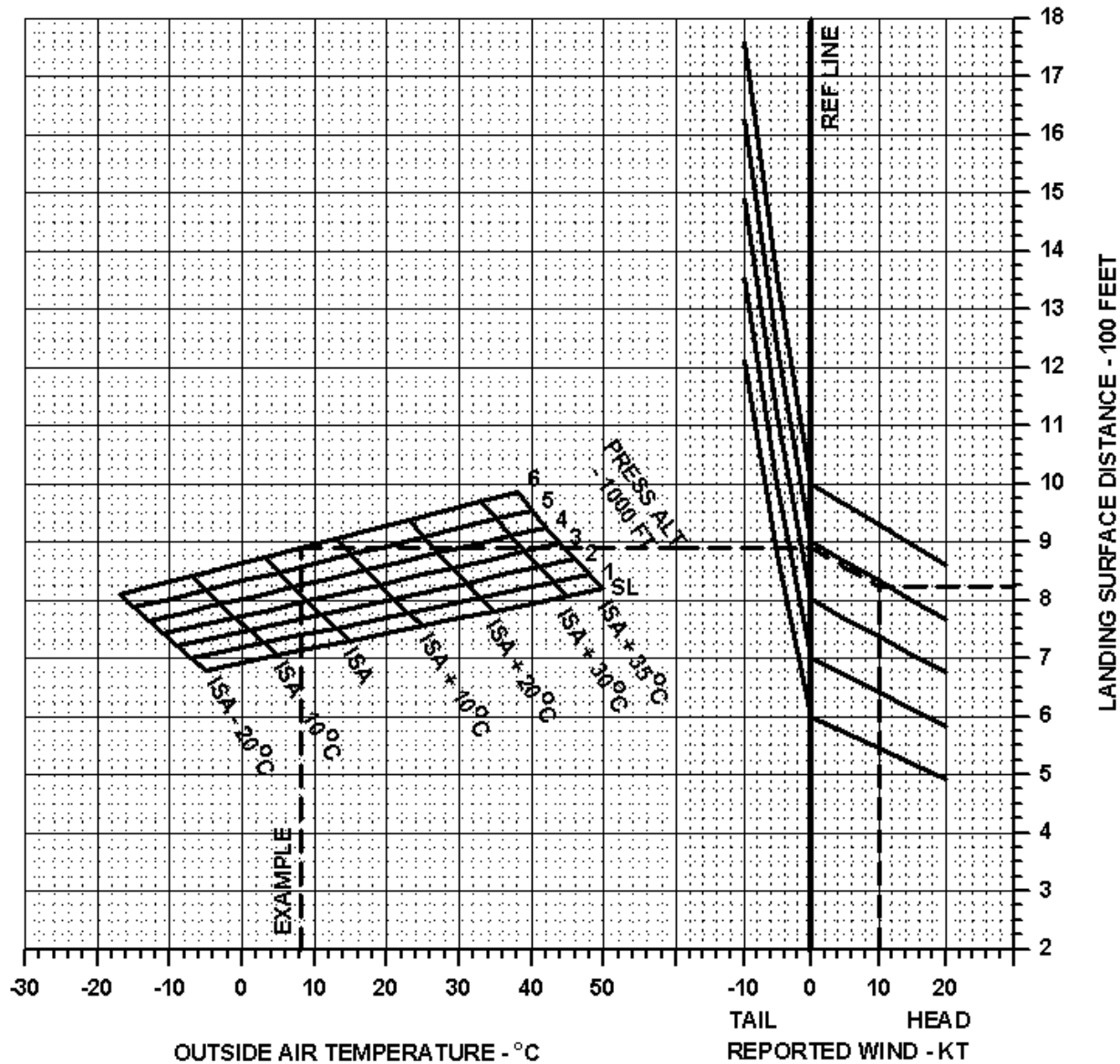


Figure 9-13-7 Landing Surface Distance with Wipaire 2100S Seaplane Floats - Water

9.13.5.5

BALKED LANDING

Pressure altitude (ft)	Airspeed (IAS)		Climb gradient (%)
	mph	knots	
5,000	58	50	4%

Figure-9-13-8 Balked Landing Climb Gradient with Wipaire 2100S Seaplane Floats

NOTE

Mixture leaned for peak RPM

9.13.5.6 GLIDE

Statute miles	Nautical miles	Altitude loss (feet)
1.3	1.1	1000
2.6	2.2	2000
3.8	3.3	3000
5.1	4.5	4000
6.4	5.6	5000
7.7	6.7	6000
9.0	7.8	7000
10.3	8.9	8000
11.5	10.0	9000
12.8	11.1	10000
14.1	12.3	11000
15.4	13.4	12000

**Figure 9-13-9 Glide Performance with Wipaire 2100S
Seaplane Floats**

NOTE

At 2300 lb. glide speed 68 mph or 59 knots, flaps up

9.13.6 WEIGHT AND BALANCE

9.13.6.1 INTRODUCTION

This section provides the position of the center of gravity relative to the datum. Should it be necessary to weigh the aircraft on seaplane floats please consult the CC18-180 maintenance manual, document TC10000AMM.

**9.13.6.2 PERTINENT INFORMATION FOR
WEIGHT AND BALANCE FOR THE CC18-
180 EQUIPPED WITH WIPAIRE 2100S
SEAPLANE FLOATS**

Position of datum60 inches ahead
of wing leading edge

Maximum gross weight 2300 lb.

Center of gravity limits at 2300 lb.

Forward..... 75.0 in. aft of datum

Aft..... 79.0 in. aft of datum

Center of gravity limits at 1600 lb. or less

Forward..... 70.5 in. aft of datum

Aft..... 79.0 in. aft of datum

Minimum operating weight 1300 lb.

Please note that the CC18-180 must not be operated under 1300 lbs. It is very unlikely that a pilot will ever encounter this situation, given the empty weight of the standard aircraft with a pilot and adequate fuel.

9.13.6.3 DETERMINATION OF EMPTY WEIGHT

The empty weight and the position of the center of gravity are recorded in Section 6 of this manual.

The weight and moments of the Wipaire 2100S seaplane float system are given in Table 9-13-1.

Item	WT lb.	Arm in.
2100S seaplane floats with attachment gear, oar and bilge pumps Left float S/N _____ Right float S/N _____		

Table 9-13-1 Weight of Wipaire 2100S Seaplane Floats

**9.13.6.4 WEIGHT AND BALANCE
DETERMINATION FOR FLIGHT**

In order to calculate the weight and balance of the aircraft:

1. Insert the respective loads in Table 9-13-2.
2. Multiply each load by its respective arm and note the moment.
3. Add the loads to calculate the takeoff weight.
4. Add the moments to compute the total moment.
5. Divide the moment by the takeoff weight. This is the final position of the center of gravity.
6. Plot the point on Figure 9-13-16. If it is within the weight and balance envelope, the aircraft is within the approved envelope.

**SECTION 9.13
SUPPLEMENTS-WIPAIRE 2100S
SEAPLANE FLOATS**

**CUB CRAFTERS
CC18-180**

	Weight (lb.)	Arm (in.)	Moment (lb-in/1000)
Basic empty weight			
Float hatches (50 lb limit)		55	
Pilot		71	
Passenger		97	
Fuel		84	
Cargo under seat (5 lb limit)		97	
Forward cargo compartment (behind passenger) (180 lb limit)		117	
Extended cargo compartment (behind forward compartment) (20 lb limit)		153	
Storage/accessory compartment		150	
Takeoff weight			

**Table 9-13-2 Weight and Balance Loading Form with
Wipaïre 2100S floats**

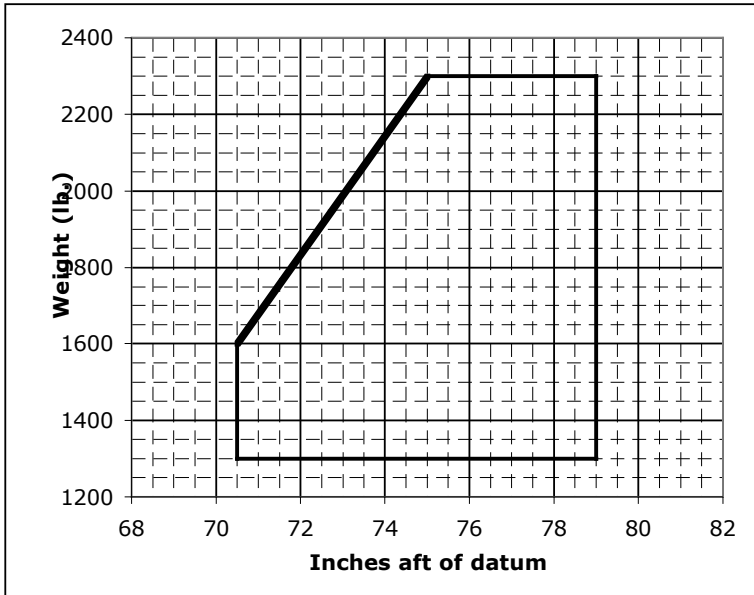


Figure 9-13-10 Weight and Balance Envelope with Wipaire 2100S Seaplane Floats

**9.13.6.5 SAMPLE WEIGHT AND BALANCE
CALCULATION**

This section will provide a sample weight and balance calculation using the methods given in paragraph 9.13.6.4.

	Weight (lb.)	Arm (in.)	Moment (lb-in)
Basic empty weight (inc. oil and unusable fuel)	1450	70	101500
Float hatches	50	55	2875
Pilot	230	71	16330
Passenger	200	97	19400
Fuel	200	84	16800
Cargo under seat (5 lb. limit)	5	97	485
Forward cargo compartment (behind passenger) (180 lb. limit)	50	117	5850
Extended cargo compartment (behind forward compartment) (20 lb. limit)	20	153	3060
Storage/accessory compartment	0	150	0
Takeoff weight	2205	75.4	166300

Table 9-13-3 Sample Weight and Balance with Wipaïre 2100S Seaplane Floats

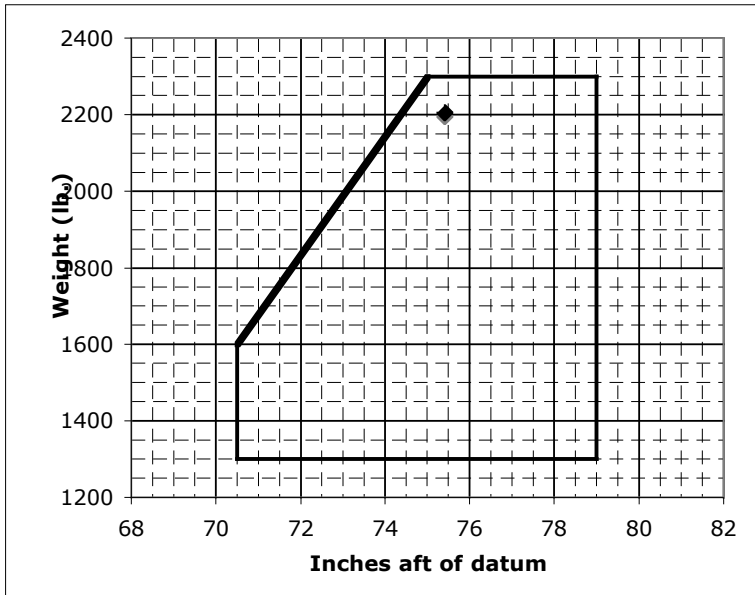


Figure 9-13-11 Sample Loading Calculation

9.13.7 DESCRIPTION AND OPERATION

9.13.7.1 GENERAL

Water operation procedures are similar to any floatplane. The instructions contained in this section will relate to the operation of the specific features of the Wipaire 2100S seaplane floats.

9.13.7.3 FUEL QUANTITY INDICATORS

Fuel indications in the water will vary depending on the angle at which the aircraft is floating. Generally, using the markings for level flight will ensure that the amount of fuel available is greater than what is shown on the gauges. However, the additional weight of this fuel must be taken into account for weight and balance.

9.13.7.4 BILGE PUMP

There is a bilge pump that is stowed in the hatch in the right float. Any water that has accumulated in the floats may be emptied out by removing the rubber plugs and using the pump to draw the water out. Make sure that no one is standing in the way of the water stream.

INTENTIONALLY LEFT BLANK

9.14 GARMIN GTN 635 GPS/COM

9.14.1 GENERAL

This supplement must be attached to the Pilot's Operating Handbook and FAA Approved Airplane Flight Manual when the Garmin GTN 635 is installed per the Equipment List supplied with the aircraft and listed in Section 6 of this manual. The information contained herein supplements or supersedes the basic Pilot's Operating Handbook and FAA Approved Flight Manual only in those areas listed in this supplement. For limitations, procedures and performance information not contained in this supplement, consult Section 2 of this Pilot's Operating Handbook and FAA Approved Airplane Flight Manual.

This supplement has been FAA approved as a permanent part of the handbook and must remain in the handbook at all times when the Garmin GTN 635 is installed.

9.14.1.1 DESCRIPTION

The Garmin GTN navigation system is a GPS system with a Satellite Based Augmentation System (SBAS), comprised of one or more Garmin TSO-C146c GTN 625, 635, 650, 725, or 750 navigator(s) and one or more Garmin approved GPS/SBAS antenna(s). The GTN navigation system is installed in accordance with AC 20-138A.

GTN system functions include:

- GPS SBAS Navigation:
 - Oceanic, enroute, terminal, and non-precision approach guidance
 - Precision approach guidance (LP, LPV)
- VHF Com Radio, 118.00 to 136.990, MHz, 8.33 or 25 kHz increments.

- Moving map including topographic, terrain, aviation, and geopolitical data.
- Display traffic data, including ADS-B (optional)
- Supplement calculators and timers.

The GPS navigation functions and optional VHF communication and navigation radio functions are operated by dedicated hard keys, a dual concentric rotary knob, or the touchscreen.



Figure 1 - GTN 635 Control and Display Layout

9.14.1.2 SYSTEM CAPABILITIES

The GTN system and associated navigation interface in this aircraft have the following capabilities, in addition to the core multifunction display capability:

- VHF Communication Radio
- Primary VHF Navigation
- Primary GPS Navigation

9.14.1.3 GPS/SBAS TSO-C146c CLASS 3 OPERATION

The GTN complies with AC 20-138A and has airworthiness approval for navigation using GPS and SBAS (within the coverage of a Satellite Based Augmentation System complying with ICAO Annex 10) for IFR en route, terminal area, and non-precision approach operations (including those approaches titled “GPS”, “or GPS”, and “RNAV (GPS)” approaches). The Garmin GNSS navigation system is composed of the GTN navigator and antenna, and is approved for approach procedures with vertical guidance including “LPV” and “LNAV/VNAV” and without vertical guidance including “LP” and “LNAV,” within the U.S. National Airspace System.

The Garmin GNSS navigation system complies with the equipment requirements of AC 90-105 and meets the equipment performance and functional requirements to conduct RNP terminal departure and arrival procedures and RNP approach procedures without RF (radius to fix) legs. Part 91 subpart K, 121, 125, 129, and 135 operators require operational approval from the FAA.

The Garmin GNSS navigation system complies with the equipment requirements of AC 90-100A for RNAV 2 and RNAV 1 operations.

In accordance with AC 90-100A, Part 91 operators (except subpart K) following the aircraft and training guidance in AC 90-100A are authorized to fly RNAV 2 and RNAV 1 procedures. Part 91 subpart K, 121, 125, 129, and 135 operators require operational approval from the FAA.

The Garmin GNSS navigation system complies with the accuracy, integrity, and continuity of function, and contains the minimum system functions required for P-RNAV operations in accordance with JAA Administrative & Guidance Material Section One: General Part 3:

Temporary Guidance Leaflets, Leaflet No 10 (JAA TGL-10 Rev 1). The GNSS navigation system has one or more TSO-C146c Class 3 approved Garmin GTN Navigation Systems. The Garmin GNSS navigation system complies with the accuracy, integrity, and continuity of function, and contains the minimum system functions required for B-RNAV operations in accordance with EASA AMC 20-4. The Garmin GNSS navigation system complies with the equipment requirements for P-RNAV and B-RNAV/RNAV-5 operations in accordance with AC 90-96A CHG 1. This does not constitute an operational approval.

Garmin International holds an FAA Type 2 Letter of Acceptance (LOA) in accordance with AC 20-153 for database integrity, quality, and database management practices for the navigation database. Flight crew and operators can view the LOA status at FlyGarmin.com then select "Type 2 LOA Status."

Navigation information is referenced to the WGS-84 reference system.

Note that for some types of aircraft operation and for operation in non-U.S. airspace, separate operational approval(s) may be required in addition to equipment installation and airworthiness approval.

9.14.2 DEFINITIONS

The following terminology is used within this document:

ADF:	Automatic Direction Finder
ADS-B:	Automatic Dependent Surveillance Broadcast
AEG:	Aircraft Evaluation Group (FAA)
APR:	Approach
CDI:	Course Deviation Indicator
DME:	Distance Measuring Equipment

EFB:	Electronic Flight Bag
EHSI:	Electronic Horizontal Situation Indicator
FIS-B:	Flight Information Services Broadcast
GNSS:	Global Navigation Satellite System
GPS:	Global Positioning System
GPSS:	GPS Roll Steering
GTN:	Garmin Touchscreen Navigator
HSI:	Horizontal Situation Indicator
IAP:	Instrument Approach Procedure
IFR:	Instrument Flight Rules
ILS:	Instrument Landing System
IMC:	Instrument Meteorological Conditions
LDA:	Localizer Directional Aid
LNAV:	Lateral Navigation
LNAV+V:	Lateral Navigation with advisory Vertical Guidance
L/VNAV:	Lateral/Vertical Navigation
LOC:	Localizer
LOC-BC:	Localizer Backcourse
LP:	Localizer Performance
LPV:	Localizer Performance with Vertical Guidance
MLS:	Microwave Landing System
NOTAM:	Notice to Airmen
OBS:	Omnibearing Select
RAIM:	Receiver Autonomous Integrity Monitoring
RMT:	Remote
RNAV:	Area Navigation
RNP:	Required Navigational Performance
SBAS:	Satellite Based Augmentation System
SD:	Secure Digital
SDF:	Simplified Directional Facility
SUSP:	Suspend

TACAN:	Tactical Air Navigation System
TAS:	Traffic Awareness System
TAWS:	Terrain Awareness and Warning System
TCAS:	Traffic Collision Avoidance System
TFR:	Temporary Flight Restriction
TIS:	Traffic Information Service
VHF:	Very High Frequency
VFR:	Visual Flight Rules
VLOC:	VOR/Localizer
VMC:	Visual Meteorological Conditions
VOR:	VHF Omnidirectional Range
WAAS:	Wide Area Augmentation System
WFDE:	WAAS Fault Data Exclusion
XFR:	Transfer

9.14.3 LIMITATIONS

9.14.3.1 COCKPIT REFERENCE GUIDE

The Garmin GTN 6XX Cockpit Reference Guide, P/N 190-01004-04 Rev C (or later revisions), must be immediately available to the flight crew whenever navigation is predicated on the use of the GTN.

9.14.3.2 KINDS OF OPERATION

The CC18-180 is limited to day/night/VFR operations only. This AFM supplement does not grant approval for IFR operations to aircraft limited to VFR operations.

9.14.3.3 FLIGHT PLANNING

For flight planning purposes, in areas where SBAS coverage is not available, the flight crew must check RAIM availability.

- Within the United States, RAIM availability can be determined using the Garmin WFDE Prediction

program, Garmin part number 006-A0154-04 (included in GTN trainer) software version 3.00 or later approved version with Garmin approved antennas or the FAA's en route and terminal RAIM prediction website: www.raimprediction.net, or by contacting a Flight Service Station.

- Within Europe, RAIM availability can be determined using the Garmin WFDE Prediction program or Europe's AUGER GPS RAIM Prediction Tool at <http://augur.ecacnav.com/augur/app/home>.
- For other areas, use the Garmin WFDE Prediction program.

This RAIM availability requirement is not necessary if SBAS coverage is confirmed to be available along the entire route of flight. The route planning and WFDE prediction program may be downloaded from the Garmin website on the internet. For information on using the WFDE Prediction Program, refer to Garmin WAAS FDE Prediction Program, part number 190-00643-01, 'WFDE Prediction Program Instructions'.

For flight planning purposes, for operations within the U.S. National Airspace System on RNP and RNAV procedures when SBAS signals are not available, the availability of GPS RAIM shall be confirmed for the intended route of flight. In the event of a predicted continuous loss of RAIM of more than five minutes for any part of the intended route of flight, the flight shall be delayed, canceled, or rerouted on a track where RAIM requirements can be met. The flight may also be re-planned using non-GPS based navigational capabilities.

For flight planning purposes for operations within European B-RNAV/RNAV-5 and P-RNAV airspace, if more than one satellite is scheduled to be out of service, then the availability of GPS RAIM shall be confirmed for the

intended flight (route and time). In the event of a predicted continuous loss of RAIM of more than five minutes for any part of the intended flight, the flight shall be delayed, cancelled, or rerouted on a track where RAIM requirements can be met.

Whenever possible, RNP and RNAV routes including Standard Instrument Departures (SIDs), Standard Terminal Arrival (STAR), and enroute RNAV “Q” and RNAV “T” routes should be loaded into the flight plan from the database in their entirety, rather than loading route waypoints from the database into the flight plan individually. Selecting and inserting individual named fixes from the database is permitted, provided all fixes along the published route to be flown are inserted. Manual entry of waypoints using latitude/longitude or place/bearing is prohibited.

It is not acceptable to flight plan a required alternate airport based on RNAV(GPS) LP/LPV or LNAV/VNAV approach minimums. The required alternate airport must be flight planned using an LNAV approach minimums or available ground-based approach aid.

Navigation information is referenced to the WGS-84 reference system, and should only be used where the Aeronautical Information Publication (including electronic data and aeronautical charts) conform to WGS-84 or equivalent.

9.14.3.4 SYSTEM USE

The only approved sources of course guidance are on the external CDI, HSI, or EHSI display. The moving map and CDI depiction on the GTN display are for situational awareness only and are not approved for course guidance.

9.14.3.5 APPLICABLE SYSTEM SOFTWARE

This AFMS/AFM is applicable to the software versions shown in Table 1.

The Main and GPS software versions are displayed on the start-up page immediately after power-on. All software versions displayed in Table 1 can be viewed on the System – System Status page.

Software Item	Software Version <i>(or later FAA Approved versions)</i>
Main SW Version	3.00
GPS SW Version	5.0
Com SW Version	2.10
Nav SW Version	6.02

Table 1 - Software Versions

9.14.3.6 SD CARD

It is required that the SD card be present in the unit at all times.

9.14.3.7 NAVIGATION DATABASE

GPS/SBAS based IFR enroute, oceanic, and terminal navigation is prohibited.

Discrepancies that invalidate a procedure should be reported to Garmin International. The affected procedure is prohibited from being flown using data from the navigation database until a new navigation database is installed in the aircraft and verified that the discrepancy has been corrected. Navigation database discrepancies can be reported at FlyGarmin.com by selecting “Aviation Data Error Report.” Flight crew and operators can view navigation database alerts at FlyGarmin.com then select “NavData Alerts.”

If the navigation database cycle will change during flight, the flight crew must ensure the accuracy of navigation data, including suitability of navigation facilities used to define the routes and procedures for flight. If an amended chart affecting navigation data is published for the procedure, the database must not be used to conduct the procedure.

9.14.3.8 GROUND OPERATIONS

Do not use SafeTaxi or Chartview functions as the basis for ground maneuvering. SafeTaxi and Chartview functions do not comply with the requirements of AC 20-159 and are not qualified to be used as an airport moving map display (AMMD). SafeTaxi and Chartview are to be used by the flight crew to orient themselves on the airport surface to improve flight crew situational awareness during ground operations.

9.14.3.9 APPROACHES

CAUTION

The following information explains the GTN functionality and procedures for instrument approaches. The CC18 is not approved for IFR operations and any such approaches must be carried out in VMC under VFR.

- a) Instrument approaches using GPS guidance may only be conducted when the GTN is operating in the approach mode. (LNAV, LNAV+V, L/VNAV, LPV, or LP)
- b) When conducting instrument approaches referenced to true North, the NAV Angle on the System -Units page must be set to **True**.
- c) The navigation equipment required to join and fly an instrument approach procedure is indicated by the title of the procedure and notes on the IAP chart. Navigating the final approach segment (that segment from the final

approach fix to the missed approach point) of an ILS, LOC, LOC-BC, LDA, SDF, MLS, VOR, TACAN approach, or any other type of approach not approved for GPS, is not authorized with GPS navigation guidance. GPS guidance can only be used for approach procedures with GPS or RNAV in the procedure title. When using the Garmin VOR/LOC/GS receivers to fly the final approach segment, VOR/LOC/GS navigation data must be selected and presented on the CDI of the pilot flying.

- d) Advisory vertical guidance deviation is provided when the GTN annunciates LNAV + V. Vertical guidance information displayed on the VDI in this mode is only an aid to help flight crews comply with altitude restrictions. When using advisory vertical guidance, the flight crew must use the primary barometric altimeter to ensure compliance with all altitude restrictions.
- e) Not all published Instrument Approach Procedures (IAP) are in the navigation database. Flight crews planning to fly an RNAV instrument approach must ensure that the navigation database contains the planned RNAV Instrument Approach Procedure and that approach procedure must be loaded from the navigation database into the GTN system flight plan by its name. Users are prohibited from flying any approach path that contains manually entered waypoints.
- f) IFR approaches are prohibited whenever any physical or visual obstruction (such as a throw-over yoke) restricts pilot view or access to the GTN and/or the CDI.

9.14.3.10 TERRAIN PROXIMITY FUNCTION (ALL UNITS)

Terrain and obstacle information appears on the map and terrain display pages as red and yellow tiles or towers, and is depicted for advisory use only. Aircraft maneuvers and navigation must not be predicated upon the use of the

terrain display. Terrain and obstacle information is advisory only.

The terrain display is intended to serve as a situational awareness tool only. By itself, it may not provide either the accuracy or the fidelity on which to base decisions and plan maneuvers to avoid terrain or obstacles.

**9.14.3.11 DATALINKED WEATHER DISPLAY
(OPTIONAL)**

This limitation applies to datalinked weather products from SiriusXM via a GDL 69/69A, FIS-B via a GDL 88, and Connex via a GSR 56.

Do not use data link weather information for maneuvering in, near, or around areas of hazardous weather. Information provided by data link weather products may not accurately depict current weather conditions.

Do not use the indicated data link weather product age to determine the age of the weather information shown by the data link weather product. Due to time delays inherent in gathering and processing weather data for data link transmission, the weather information shown by the data link weather product may be significantly older than the indicated weather product age.

Do not rely solely upon data link services to provide Temporary Flight Restriction (TFR) or Notice to Airmen (NOTAM) information. Not all TFRs and NOTAMS can be depicted on the GTN.

9.14.3.12 TRAFFIC DISPLAY (OPTIONAL)

Traffic may be displayed on the GTN when connected to an approved optional TCAS I, TAS, TIS, or ADS-B traffic device. These systems are capable of providing traffic monitoring and alerting to the flight crew. Traffic shown on the display may or may not have traffic alerting available. The display of traffic is an aid to visual acquisition and may not be utilized for aircraft maneuvering.

**9.14.3.13 FLIGHT PLANNER / CALCULATOR
FUNCTIONS**

CAUTION

When using the Density Altitude / True Airspeed / Winds page, all data must be entered into the calculator before the calculated data is used. Calculated data may not be correct prior to entering all data.

The Fuel Planning page uses Fuel on Board or Fuel Flow as received from an on board fuel totalizer, as entered by the pilot at system startup, or as entered by the pilot when on the Fuel Planning page. This *is not* a direct indication of actual aircraft fuel flow or fuel on board and those values are only used for the Fuel Planning page. The fuel required to destination is only a calculated and predicted value based on the data entered into the planner. It is not a direct indication of how much fuel the aircraft will have upon reaching the destination. Certain approach leg types will result in the fuel burn incorrectly calculated as zero.

9.14.3.14 GLOVE USE / COVERED FINGERS

No device may be used to cover fingers used to operate the GTN unless the Glove Qualification Procedure located in the Pilot's Guide/Cockpit Reference Guide has been successfully completed. The Glove Qualification Procedure

is specific to a pilot / glove / GTN 725, 750 or GTN 625, 635, 650 combination.

9.14.3.15 DEMO MODE

Demo mode may not be used in flight under any circumstances.

9.14.4 EMERGENCY PROCEDURES

9.14.4.1 ABNORMAL PROCEDURES

9.14.4.1.1 LOSS OF GPS/SBAS NAVIGATION DATA

When the GPS/SBAS receiver is inoperative or GPS navigation information is not available or invalid, the GTN will enter one of two modes: Dead Reckoning mode (DR) or Loss of Integrity mode (LOI). The mode is indicated on the GTN by an amber “DR” or “LOI”.

If the Loss of Integrity annunciation is displayed, revert to an alternate means of navigation appropriate to the route and phase of flight.

If the Dead Reckoning annunciation is displayed, the map will continue to be displayed with an amber ‘DR’ overwriting the ownship icon. Course guidance will be removed on the CDI. Aircraft position will be based upon the last valid GPS position, then estimated by Dead Reckoning methods. Changes in true airspeed, altitude, heading, or winds aloft can affect the estimated position substantially. Dead Reckoning is only available in Enroute and Oceanic modes. Terminal and Approach modes do not support Dead Reckoning.

If Alternate Navigation Sources (ILS, LOC, VOR, DME, ADF) Are Available:

Navigation..... USE ALTERNATE SOURCES

If No Alternate Navigation Sources Are Available:

DEAD RECKONING (DR) MODE:

Navigation..... USE GTN

NOTE

All information normally derived from GPS will become less accurate over time.

LOSS OF INTEGRITY (LOI) MODE:

Navigation..... REVERT TO ALTERNATE MEANS OF NAVIGATION

NOTE

All information derived from GPS will be removed

NOTE

The airplane symbol is removed from all maps. The map will remain centered at the last known position. "NO GPS POSITION" will be annunciated in the center of the map.

9.14.4.1.2 GPS APPROACH DOWNGRADE

CAUTION

The following information explains the GTN functionality and procedures for instrument approaches. The CC18 is not approved for IFR operations and any such approaches must be carried out in VMC under VFR.

During a GPS LPV, LNAV/VNAV, or LNAV+V approach, if GPS accuracy requirements cannot be met by the GPS receiver, the GTN will downgrade the approach. The downgrade will remove vertical deviation indication from

the VDI and change the approach annunciation accordingly from LPV, L/VNAV, or LNAV+V to LNAV. The approach may be continued using the LNAV only minimums.

During a GPS approach in which GPS accuracy requirements cannot be met by the GPS receiver for any GPS approach type, the GTN will flag all CDI guidance and display a system message "ABORT APPROACH-GPS approach no longer available". Immediately upon viewing the message, the unit will revert to Terminal navigation mode alarm limits.

If the position integrity is within these limits lateral guidance will be restored and the GPS may be used to execute the missed approach, otherwise alternate means of navigation must be utilized.

9.14.4.1.3 LOSS OF COM RADIO TUNING FUNCTIONS

If alternate COM is available:

Communications..... USE ALTERNATE COM

If no alternate COM is available:

COM RMT XFR key (if installed)..... PRESS AND HOLD
FOR 2 SECONDS

NOTE

This procedure will tune the active COM radio the emergency frequency 121.5, regardless of what frequency is displayed on the GTN. Certain failures of the tuning system will automatically tune 121.5 without flight crew action.

9.14.4.1.4 LOSS OF AUDIO PANEL FUNCTIONS (GMA 35 ONLY)

Audio Panel Circuit Breaker.....PULL

NOTE

This procedure will force the audio panel into fail safe mode which provides only the pilot with communications and only on a single COM radio. Communication will be only on that radio. No other audio panel functions including the crew and passenger intercom will function.

9.14.4.1.5 TER N/A AND TER FAIL

If the amber **TER N/A** or **TER FAIL** status annunciator is displayed, the system will no longer provide relative terrain and obstacle elevations. The crew must maintain compliance with VFR procedures that ensure minimum terrain and obstacle separation at all times.

9.14.4.1.6 DATA SOURCE – PRESSURE ALTITUDE SOURCE INOPERATIVE OR CONNECTION TO GTN LOST MESSAGE

Without a barometric altitude source to the GTN, the following features will not operate:

- Automatic leg sequencing of legs requiring an altitude source. The flight crew must manually sequence altitude legs, as prompted by the system.

9.14.4.1.7 UNRECOVERABLE LOSS OF ALL ELECTRICAL GENERATORS OR ALTERNATORS

Remove power from all equipment which is not necessary for flight.

9.14.5 NORMAL PROCEDURES

Refer to the Cockpit Reference Guide defined in Section 9.14.3.1 of this document or the Pilot's Guide defined in Section 9.14.8.1 for normal operating procedures and a complete list of system messages and associated flight crew actions. This includes all GPS operations, VHF

communication and navigation, traffic, data linked weather, and Multi-Function Display information.

The GTN requires a reasonable degree of familiarity to avoid becoming too engrossed at the expense of basic see-and-avoid in VMC. Garmin provides training tools with the Pilot's Guide and PC based simulator. Pilots should take full advantage of these training tools to enhance system familiarization.

CAUTION

The following information explains the GTN functionality and procedures for instrument approaches. The CC18 is not approved for IFR operations and any such approaches must be carried out in VMC under VFR.

9.14.5.1 UNIT POWER ON

Database REVIEW EFFECTIVE DATES
Self Test VERIFY OUTPUTS TO NAV INDICATORS

9.14.5.2 BEFORE TAKEOFF

System Messages and Annunciators CONSIDERED

9.14.5.3 HSI AND EHSI OPERATION

If an HSI is used to display navigation data from the GTN the pilot should rotate the course pointer as prompted on the GTN.

If an EHSI is used to display navigation data from the GTN the course pointer may autoslew to the correct course when using GPS navigation. When using VLOC navigation the course pointer will not autoslew and must be rotated to the correct course by the pilot. For detailed information about the functionality of the EHSI system, refer to the FAA approved Flight Manual or Flight Manual Supplement for that system.

CAUTION

The pilot must verify the active course and waypoint for each flight plan leg. The pilot must verify proper course selection each time the CDI source is changed from GPS to VLOC.

9.14.5.4 TELEPHONE & SMS TEXT (OPTIONAL)

Audio from the GSR 56 Iridium datalink is routed through your aircraft's audio panel Audio from the GSR 56 must be deactivated (turned off) unless making a phone call. The primary indication of an incoming phone call or SMS text are the visual indications on the GTN.

9.14.6 PERFORMANCE

No change.

9.14.7 WEIGHT AND BALANCE

No change.

9.14.8 SYSTEM DESCRIPTIONS

9.14.8.1 PILOT'S GUIDE

The Garmin GTN 6XX Pilot's Guide, part number and revision listed below, contain additional information regarding GTN system description, control and function. The Pilot's Guide does not need to be immediately available to the flight crew.

- GTN 6XX Pilot's Guide P/N 190-01004-03 Rev C or later

9.14.8.2 LEG SEQUENCING

The GTN supports all ARINC 424 leg types. Certain leg types require altitude input in order to sequence (course to altitude, for example). If a barometric corrected altitude source is not interfaced to the GTN, a popup will appear prompting the flight crew to manually sequence the leg once the altitude prescribed in the procedure is reached.

- This installation does not have a barometric corrected altitude source. The flight crew will be prompted to manually sequence altitude legs.

9.14.8.3 AUTO ILS CDI CAPTURE

Auto ILS CDI Capture will not automatically switch from GPS to VLOC for LOC-BC or VOR approaches.

9.14.8.4 ACTIVATE GPS MISSED APPROACH

- This installation will not autoswitch from VLOC to GPS when the “Activate GPS Missed Approach” button is pressed. The pilot must manually switch from VLOC to GPS if GPS guidance is desired after the missed approach point.

9.14.8.5 TERRAIN PROXIMITY

- The Obstacle Database has an area of coverage that includes the United States and Europe, and is updated as frequently as every 56 days.

NOTE

The area of coverage may be modified as additional terrain data sources become available.

- This installation supports Terrain Proximity. No aural or visual alerts for terrain or obstacles are provided. Terrain Proximity does not satisfy the TAWS requirement of 91.223.

9.14.8.6 TRAFFIC SYSTEM (OPTIONAL)

This system is configured for the following type of traffic system. The Garmin GTN 6XX Cockpit Reference Guide or Garmin GTN 6XX Pilot’s Guide provides additional information regarding the functionality of the traffic device.

- A TIS traffic system is interfaced to the GTN.

9.14.8.7 POWER

- Power to the GTN is provided through a circuit breaker labeled GPS.
- Power to the optional GTN COM is provided through a circuit breaker labeled COM.

9.14.8.8 DATABASES

Database versions and effective dates are displayed on the start-up page immediately after power-on. Database information can also be viewed on the System – System Status page.

The Obstacle Database coverage area includes the United States and Europe.

9.14.8.9 AIRSPACE DEPICTION AND ALERTS

The GTN aids the flight crew in avoiding certain airspaces with Smart Airspace and airspace alerts. Smart Airspace de-emphasizes depicted airspace that is not near the aircraft's current altitude. Airspace Alerts provide a message indication to the flight crew when the aircraft's current ground track will intercept an airspace type that has been selected for alerting.

NOTE

Smart Airspace and Airspace Alerts are separate features. Turning on/off Smart Airspace does not affect Airspace Alerts, and vice versa.

9.14.8.10 TRANSPONDER CONTROL (OPTIONAL)

The GTN can be interfaced to a Garmin transponder for control and display of squawk code, mode, and additional transponder functions. The activation of the "Enable ES" button on the transponder page does not indicate the aircraft is in full compliance with an ADS-B Out solution in accordance with TSO-C166b (1090ES). Consult your transponder documentation for additional information.

9.15 REAR CONTROL STICK COVER

9.15.1 GENERAL

This supplement must be attached to the Pilot's Operating Handbook and FAA Approved Airplane Flight Manual when the REAR CONTROL STICK COVER is installed. The information contained herein supplements or supersedes the Pilot's Operating Handbook and FAA Approved Flight Manual only in those areas listed in this supplement. For limitations, procedures and performance information not contained in this supplement, consult Section 2 of this Pilot's Operating Handbook and FAA Approved Airplane Flight Manual.

This supplement has been FAA approved as a permanent part of the handbook and must remain in the handbook at all times when the REAR CONTROL STICK COVER is installed.

9.15.1.1 DESCRIPTION

This supplement describes the process and requirements for removing and reinstalling the rear control stick. This conversion is considered an owner/operator task.

9.15.2 LIMITATIONS

The minimum required flight crew is one pilot in the front seat. No flight instruction may be given from the rear seat.

9.15.3 EMERGENCY PROCEDURES

There is no change to emergency procedures.

9.15.4 PERFORMANCE

There is no change to performance.

9.15.5 WEIGHT AND BALANCE

There is no change to Weight and Balance.

9.15.6 DESCRIPTION AND OPERATION

1. Remove aft stick boot cover by unsnapping eight snaps (see Figure 1).
2. Remove the tension nut, washer, and bolt to take out the rear control stick (see Figure 2). Retain all hardware for future reinstallation. Stow stick in a secure location.
3. Center the stick mast cover over the torque tube mast and position as far aft as possible.
4. Move the front control stick through the full range of motion (including trim) and ensure there is no contact between the rear stick stub and the stick cover.

- 5. Secure to cover to floorboard with four HDW-S6R-.375TA screws as shown in Figure 3.



Figure 1 – Aft Stick Boot Cover



Figure 2 – Hardware Removal

**SECTION 9.15
SUPPLEMENTS-
REAR STICK COVER INSTALLATION**

**CUB CRAFTERS
CC18-180**

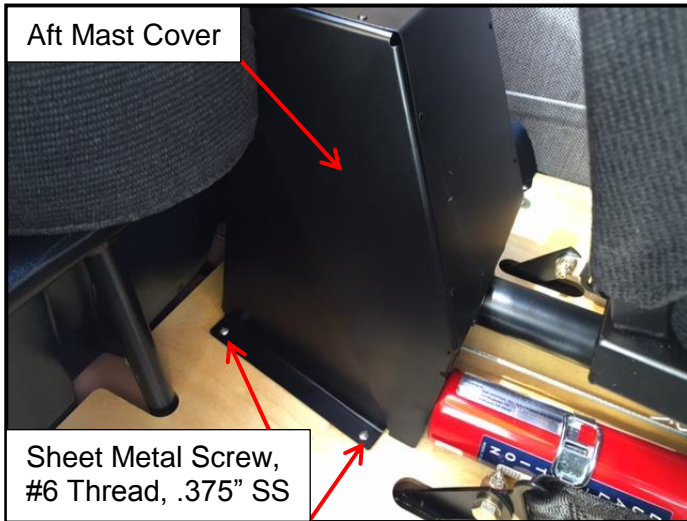


Figure 3 – Rear Control Stick Cover Installed

REAR STICK REINSTALLATION INSTRUCTIONS:

6. Remove rear control stick cover by unscrewing four screws.
7. Install the stick with the bolt, washer, and tension nut retained from previous removal. Torque the bolt to 38-43 in-lbs.
8. Ensure full range of motion (including trim) is met without the rear stick contacting anything.
9. Reinstall aft stick boot cover by securing snaps on the floor.

**9.16 AIRCRAFT WITHOUT EXTENDED CARGO
COMPARTMENT**

9.16.1 GENERAL

This supplement must be attached to the Pilot's Operating Handbook and FAA Approved Airplane Flight Manual when operating a CC18-180 that does not have the extended cargo compartment installed. The information contained herein supplements or supersedes the Pilot's Operating Handbook and FAA Approved Flight Manual only in those areas listed in this supplement. For limitations, procedures and performance information not contained in this supplement, consult Section 2 of this Pilot's Operating Handbook and FAA Approved Airplane Flight Manual.

This supplement has been FAA approved as a permanent part of the handbook and must remain in the handbook at all times when operating a CC18-180 that does not have an extended cargo compartment installed.

9.16.1.1 DESCRIPTION

This supplement applies to CC18-180 aircraft that do not have the extended cargo compartment installed.

9.16.2 LIMITATIONS

All placards listed in Section 2 of this manual must be installed, except for the one that relates to the extended cargo compartment (page 2-11).

9.16.3 EMERGENCY PROCEDURES

There are no changes to the emergency procedures.

9.16.4 NORMAL PROCEDURES

There are no changes to the normal procedures.

9.16.5 PERFORMANCE

There is no change in performance.

9.16.6 WEIGHT AND BALANCE

The extended cargo compartment referenced in Tables 6-3 and 6-4 is not installed in this aircraft.

9.16.7 DESCRIPTION AND OPERATION

(This Section replaces Section 7.9 of this manual).

There are two baggage compartments. The one under the passenger's seat has a capacity of 5 lbs. It is reached by lifting the hinged rear seat bottom.

The second compartment is behind the aft occupant. It has a capacity of 180 lbs. Cargo may be loaded over the aft seat. There are 11 tie downs and each is rated for up to 50 lbs.

Above and slightly behind the second compartment is a storage area that also houses the aircraft's battery. It may be used to stow up to 5 lbs. of soft items such as hats, coats, and covers. The visors for night operation are stowed in this compartment.

The cross tube that supports the rear seat back may be swung up to make loading bulky items easier. This is done by removing the pin and swinging the cross tube upwards. The cross tube must be secured in place prior to flight.

**SECTION 9.16
SUPPLEMENTS-
AIRCRAFT WITHOUT EXTENDED
CARGO COMPARTMENT**

**CUB CRAFTERS
CC18-180**

INTENENTIONALLY LEFT BLANK